

REPORT ON GEOPHYSICAL SURVEY
(INDUCED POLARIZATION & RESISTIVITY)
ON THE DOROTHY CLAIM GROUP,
HOGEM AREA, 93N/14W
OMINECA MINING DIVISION, B. C.
PART TWO (OF TWO) FOR
KENNCO EXPLORATIONS (WESTERN) LTD.
55° 125° NE

BY

P. G. HALLOF, PH. D.

NAME AND LOCATION OF PROPERTY:

DOROTHY CLAIM GROUP, HOGEM AREA, 55°, 125° NE

DATE STARTED - JUNE 17, 1962

DATE COMPLETED - JUNE 30, 1962

432 B

TABLE OF CONTENTS

<u>Part A:</u> Notes on theory and field procedure	6 pages	
<u>Part B:</u> Report	6 pages	<u>Page</u>
1. Introduction		1
2. Presentation of Results		1
3. Discussion of Results		3
4. Assessment Details		4
5. Summary of Cost		5
6. Certificate		6
<u>Part C:</u> Illustrations	8 pieces	
Plan Map (in pocket)		Dwg. Misc. 4717
I. P. Data Plots		Dwgs. I. P. 2901-1 to -7

Department of
Mines and Petroleum Resources
ASSESSMENT REPORT
NO. 432 MAP.....

McPHAR GEOPHYSICS LIMITED

NOTES ON THE THEORY OF INDUCED POLARIZATION AND THE METHOD OF FIELD OPERATION

Induced Polarization as a geophysical measurement refers to the blocking action or polarization of metallic or electronic conductors in a medium of ionic solution conduction.

This electro-chemical phenomenon occurs wherever electrical current is passed through an area which contains metallic minerals such as base metal sulphides. Normally, when current is passed through the ground, as in resistivity measurements, all of the conduction takes place through ions present in the water content of the rock, or soil, i. e. by ionic conduction. This is because almost all minerals have a much higher specific resistivity than ground water. The group of minerals commonly described as "metallic", however, have specific resistivities much lower than ground waters. The induced polarization effect takes place at those interfaces where the mode of conduction changes from ionic in the solutions filling the interstices of the rock to electronic in the metallic minerals present in the rock.

The blocking action or induced polarization mentioned above, which depends upon the chemical energies necessary to allow the ions to give up or receive electrons from the metallic surface, increases with the time that a d. c. current is allowed to flow through

the rock; i. e. as ions pile up against the metallic interface the resistance to current flow increases. Eventually, there is enough polarization in the form of excess ions at the interfaces to effectively stop all current flow through the metallic particle. This polarization takes place at each of the infinite number of solution-metal interfaces in a mineralized rock.

When the d. c. voltage used to create this d. c. current flow is cut off, the Coulomb forces between the charged ions forming the polarization cause them to return to their normal position. This movement of charge creates a small current flow which can be measured on the surface of the ground as a decaying potential difference.

From an alternate viewpoint it can be seen that if the direction of the current through the system is reversed repeatedly before the polarization occurs, the effective resistivity of the system as a whole will change as the frequency of the switching is changed. This is a consequence of the fact that the amount of current flowing through each metallic interface depends upon the length of time that current has been passing through it in one direction.

The values of the "metal factor" or "M. F." are a measure of the amount of polarization present in the rock mass being surveyed. This parameter has been found to be very successful in mapping areas of sulphide mineralization, even those in which all other geophysical methods have been unsuccessful. The induced polarization measurement is more sensitive to sulphide content than other electrical measurements

because it is much more dependent upon the sulphide content. As the sulphide content of a rock is increased, the "metal factor" of the rock increases much more rapidly than the resistivity decreases.

Because of this increased sensitivity, it is possible to locate and outline zones of less than 10% sulphides that can't be located by E. M. Methods. The method has been successful in locating the disseminated "porphyry copper" type mineralization in the South-western United States.

Measurements and experiments also indicate that it should be possible to locate most massive sulphide bodies at a greater depth with induced polarization than with E. M.

Since there is no I. P. effect from any conductor unless it is metallic, the method is useful in checking E. M. anomalies that are suspected of being due to water filled shear zones or other ionic conductors. There is also no effect from conductive overburden, which frequently confuses E. M. results. It would appear from scale model experiments and calculations that the apparent metal factors measured over a mineralized zone are larger if the material overlying the zone is of low resistivity.

Apropos of this, it should be stated that the induced polarization measurements indicate the total amount of metallic constituents in the rock. Thus all of the metallic minerals in the rock, such as pyrite, as well as the ore minerals chalcopryrite, chalcocite, galena, etc. are responsible for the induced polarization effect. Some

oxides such as magnetite, pyrolusite, chromite, and some forms of hematite also conduct by electrons and are metallic. All of the metallic minerals in the rock will contribute to the induced polarization effect measured on the surface.

In the field procedure, measurements on the surface are made in a way that allows the effects of lateral changes in the properties of the ground to be separated from the effects of vertical changes in the properties. Current is applied to the ground at two points a distance (X) apart. The potentials are measured at two other points (X) feet apart, in line with the current electrodes. The distance between the nearest current and potential electrodes is an integer number (N) times the basic distance (X).

The measurements are made along a surveyed line, with a constant distance (NX) between the nearest current and potential electrodes. In most surveys, several traverses are made with various values of (N); i. e. (N) = 1, 2, 3, 4, etc. The kind of survey required (detailed or reconnaissance) decides the number of values of (N) used.

In plotting the results, the values of the apparent resistivity and the apparent metal factor measured for each set of electrode positions are plotted at the intersection of grid lines, one from the center point of the current electrodes and the other from the center point of the potential electrodes. The resistivity values are plotted above the line and the metal factor values below. The lateral displacement of a given value is determined by the location along the survey

line of the center point between the current and potential electrodes. The distance of the value from the line is determined by the distance (NX) between the current and potential electrodes when the measurement was made.

The separation between sender and receiver electrodes is only one factor which determines the depth to which the ground is being sampled in any particular measurement. These plots then, when contoured, are not section maps of the electrical properties of the ground under the survey line. The interpretation of the results from any given survey must be carried out using the combined experience gained from field, model and theoretical investigations. The position of the electrodes when anomalous values are measured must be used in the interpretation.

In the field procedure, the interval over which the potential differences are measured is the same as the interval over which the electrodes are moved after a series of potential readings has been made. One of the advantages of the induced polarization method is that the same equipment can be used for both detailed and reconnaissance surveys merely by changing the distance (X) over which the electrodes are moved each time. In the past, intervals have been used ranging from 100 feet to 1000 feet for (X). In each case, the decision as to the distance (X) and the values of (N) is largely determined by the expected size of the mineral deposit being sought, the size of the expected anomaly and the speed with which it is desired to progress.

The diagram in Figure 1 below demonstrates the method used in plotting the results. Each value of the apparent resistivity and the apparent "Metal factor" is plotted and identified by the position of the four electrodes when the measurement was made. It can be seen that the values measured for the larger values of (n) are plotted farther from the line indicating that the thickness of the layer of the earth that is being tested is greater than for the smaller values of (n); i. e. the depth of the measurement is increased.

METHOD USED IN PLOTTING DIPOLE-DIPOLE
INDUCED POLARIZATION AND RESISTIVITY RESULTS

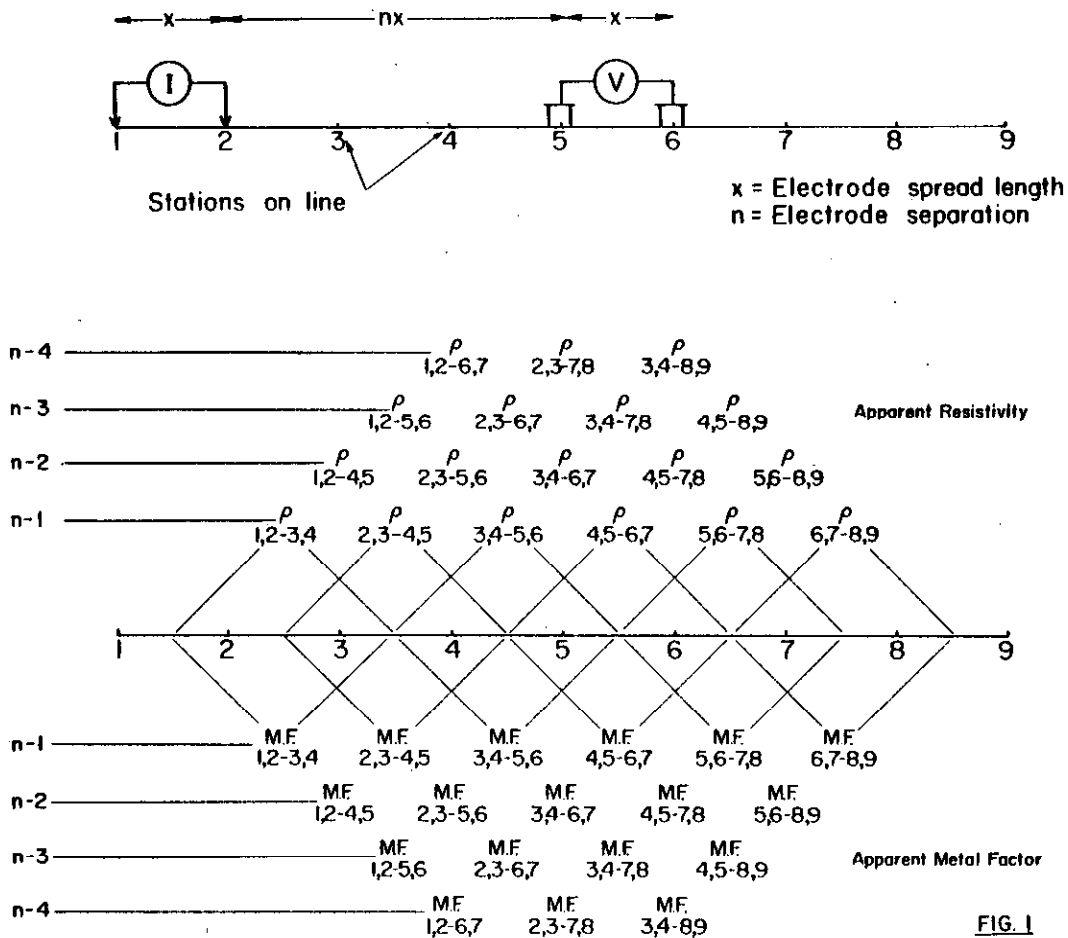

FIG. 1

McPHAR GEOPHYSICS LIMITED

**REPORT ON THE
INDUCED POLARIZATION
AND RESISTIVITY SURVEY
ON THE DOROTHY CLAIM GROUP,
HOSEM AREA,
OMINECA MINING DIVISION, B. C.
FOR
KENNCO EXPLORATIONS (WESTERN) LTD.**

1. INTRODUCTION

At the request of Mr. Hal Fleming, geophysicist for the company, a brief induced polarization and resistivity survey has been carried out on part of the Dorothy Claim Group on behalf of Kennco Explorations (Western) Limited. The property is located in the Omineca Mining Division in the northeast quadrant of the one degree quadrilateral whose southeast corner is at $55^{\circ}\text{N} - 125^{\circ}\text{W}$.

A few lines were surveyed on the property to locate any sub-surface mineralization that might be associated with favourable geological and geochemical indications mapped by the Kennco Explorations' staff. It was expected that any anomalous indications would have to be followed by a more complete survey at some future time.

2. PRESENTATION OF RESULTS

The induced polarization and resistivity results are shown on

the following enclosed data plots. The results are plotted in the manner described in the notes preceding this report.

Line 8S	200' spreads	Dwg. I. P. 2901-1
Line 4S	200' spreads	Dwg. I. P. 2901-2
Line 0+00S	200' spreads	Dwg. I. P. 2901-3
Line 8N	200' spreads	Dwg. I. P. 2901-4
Line 16N	200' spreads	Dwg. I. P. 2901-5
Line 24N	200' spreads	Dwg. I. P. 2901-6
Line 44N	200' spreads	Dwg. I. P. 2901-7

Enclosed with this report is Dwg. Misc. 4717, a plan map of the claim group showing the lines surveyed. The definite and possible induced polarization anomalies are indicated by solid and broken bars respectively on this plan map as well as the data plots. These bars represent the surface projection of the anomalous zones as interpreted from the location of the transmitter and receiver electrodes when the anomalous values were measured.

Since the induced polarization measurement is essentially an averaging process, as are all potential methods, it is frequently difficult to exactly pinpoint the source of an anomaly. Certainly, no anomaly can be located with more accuracy than the spread length; i. e. when using 200' spreads the position of a narrow sulphide body can only be determined to lie between two stations 200' apart. In order to locate sources at some depth, larger spreads must be used, with a corresponding increase in the

uncertainties of location. Therefore, while the center of the indicated anomaly probably corresponds fairly well with source, the length of the indicated anomaly along the line should not be taken to represent the exact edges of the anomalous material.

3. DISCUSSION OF RESULTS

A light-weight reconnaissance I. P. unit was used in the survey, in order to speed the survey in the area of rugged terrain. The unit is battery powered, and weighs 70 pounds. There was a large amount of electrical noise measured in the Hogem Area while the survey was being made; as a result it was difficult to make accurate frequency effect measurements for the larger values of (n) in regions where the apparent resistivities were low. When there was some noise present in the measurement, the values are shown in brackets on the data plots, and the values shown should be taken as minimums. When no measurements were possible due to noise, a question mark has been plotted instead of a reading.

The reconnaissance I. P. results on the Dorothy Group show several areas where the measured I. P. effects are above background. The most important of these are on the western end of Line 0+00 and Line 8N. Some further I. P. measurements would be warranted in this area in order to fully evaluate its importance.

McPHAR GEOPHYSICS LIMITED



Philip G. Hall of,
Geophysicist.

PGH:er

Dated: July 16, 1962.

ASSESSMENT DETAILS

PROPERTY: Dorothy Claim Group

MINING DIVISION: Omineca

SPONSOR: Kennco Explorations (Western) Ltd.

PROVINCE: British Columbia

LOCATION: Hogem Area

TYPE OF SURVEY: Induced Polarization

OPERATING MAN DAYS: 30.0

DATE STARTED: June 17, 1962

EQUIVALENT 8 HR. MAN DAYS: 45.0

DATE FINISHED: June 30, 1962

CONSULTING MAN DAYS: 1.0

NUMBER OF STATIONS OCCUPIED:
105

DRAUGHTING MAN DAYS: 2.5

NUMBER OF READINGS TAKEN:
728

TOTAL MAN DAYS: 48.5

MILES OF LINE SURVEYED: 3.7

CONSULTANTS:

Philip G. Hallof, 5 Minorca Place, Don Mills, Ontario

FIELD TECHNICIANS:

J. Lee, 264 Oriole Parkway, Toronto 7, Ontario

G. MacKay, R. R. #3, Tiverton, Ontario

3 Helpers - supplied by client

DRAUGHTSMEN:

F. R. Peer, 38 Torrens Avenue, Toronto 6, Ontario

R. MacKenzie, 55 Shannon Drive, Scarborough, Ontario

McPHAR GEOPHYSICS LIMITED



Philip G. Hallof,
Geophysicist.

Dated: July 17, 1962.

SUMMARY OF COST

Hogem Area - Dorothy Property

Crew

6 Operating days	@ \$170.00/day	\$1,020.00
1 Bad Weather days)	2 @ \$50.00/day	100.00
1 Travel day)		

Expenses

Airfare - 2 men - Watson Lake-Vancouver-Toronto	\$46.00	
Airfreight - Equipment	31.98	
Travel Expenses - 2 men (Accommodation & Meals)	<u>12.50</u>	<u>90.48</u>
		<u>\$1,210.48</u>

McPHAR GEOPHYSICS LIMITED



**Philip G. Hallof,
Geophysicist.**

Dated: July 17, 1962.

CERTIFICATE

I, Philip George Hallof, of the City of Toronto, Province of Ontario, do hereby certify that:

1. I am a geophysicist residing at 5 Minorca Place, Don Mills (Toronto), Ontario.
2. I am a graduate of the Massachusetts Institute of Technology with a B. S. Degree (1952) in Geology and Geophysics, and a Ph. D. Degree (1957) in Geophysics.
3. I am a member of the Society of Exploration Geophysicists and the European Association of Exploration Geophysicist.
4. I have been practising my profession for ten years.
5. I have no direct or indirect interest, nor do I expect to receive any interest, direct or indirect, in the property or securities of Kennco Explorations (Western) Ltd.
6. The statements made in this report are based on a study of published literature and unpublished private reports and geophysical data.

Dated at Toronto

This 17th day of July 1962

Philip G. Hallof, Ph. D.

432

McPHAR GEOPHYSICS LIMITED
INDUCED POLARIZATION AND RESISTIVITY SURVEY

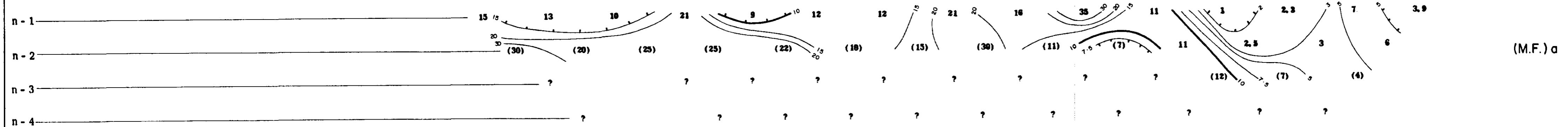
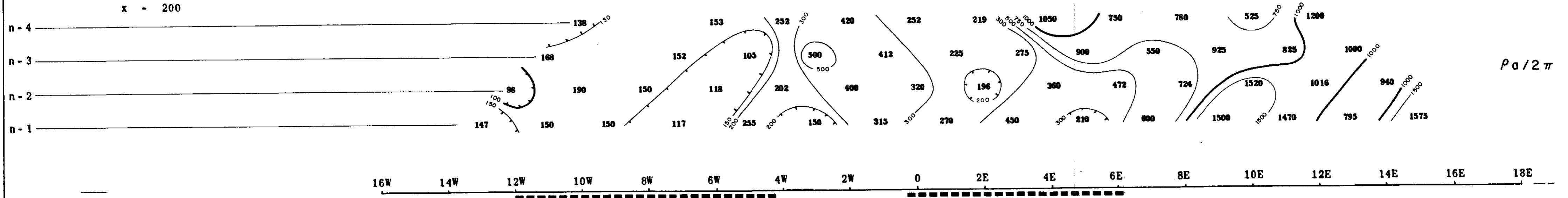
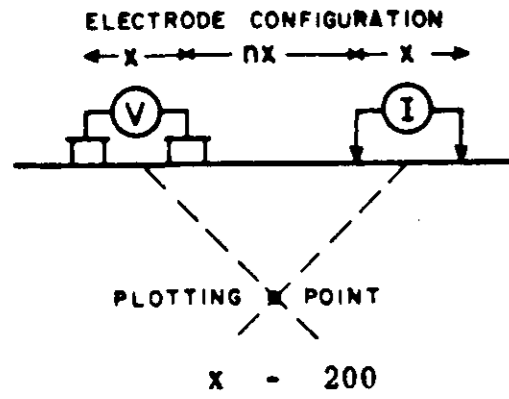

ANOMALOUS ZONE
POSSIBLE ANOMALOUS ZONE
NOTE
LOGARITHMIC CONTOUR INTERVAL

KENNCO EXPLORATIONS (WESTERN) LIMITED
DOROTHY CLAIM GROUP, HOGEM AREA—OMINECA MINING DIVISION, B.C.
Scale—One inch = 200 Feet

MI

FREQUENCY 31-5 CPS
DATE SURVEYED JUNE 1962
APPROVED
DATE 7/17/62

LINE NO. 8 S

McPHAR GEOPHYSICS LIMITED

INDUCED POLARIZATION AND RESISTIVITY SURVEY

432

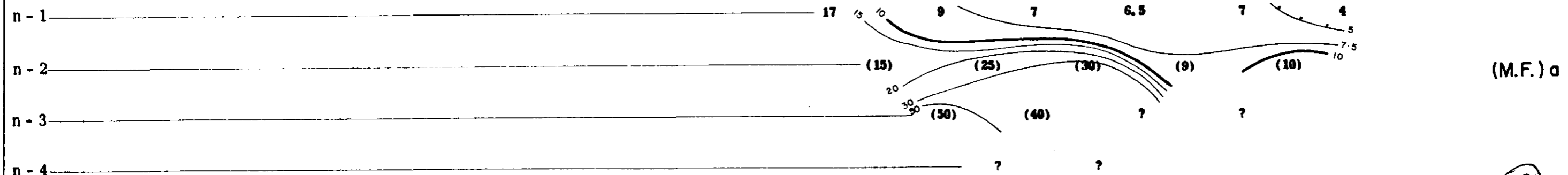
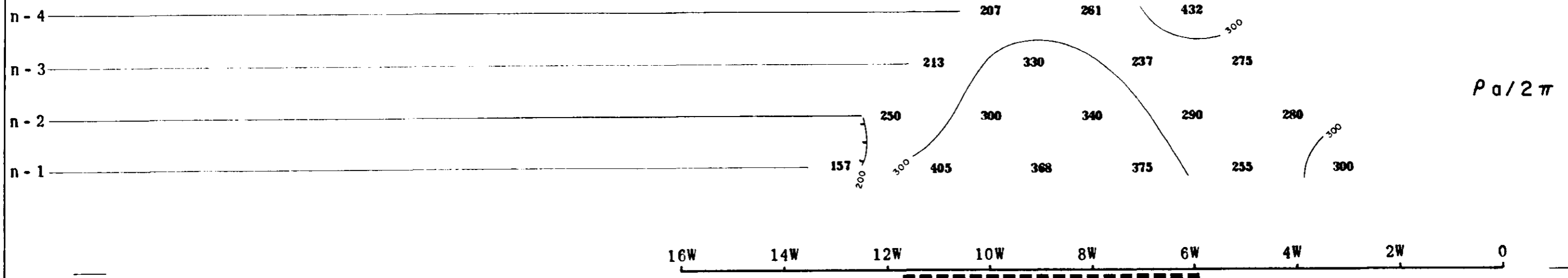
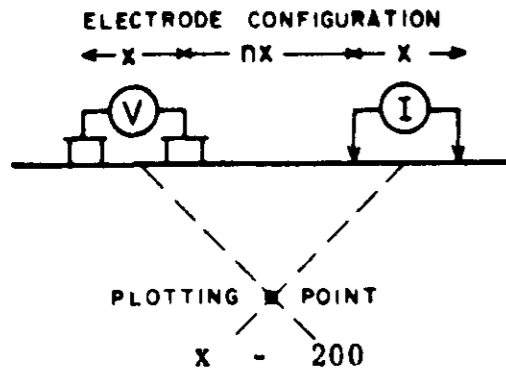

LINE NO. 4 S

MP

FREQUENCY 31-5 CPS

DATE SURVEYED JUNE 1962

APPROVED PI

DATE 7/17/62

KENNCO EXPLORATIONS (WESTERN) LIMITED
 DOROTHY CLAIM GROUP, HOGEM AREA—OMINECA MINING DIVISION, B.C.
 Scale—One inch = 200 Feet

ANOMALOUS ZONE
 POSSIBLE ANOMALOUS ZONE
 NOTE
 LOGARITHMIC CONTOUR INTERVAL

432

McPHAR GEOPHYSICS LIMITED

INDUCED POLARIZATION AND RESISTIVITY SURVEY

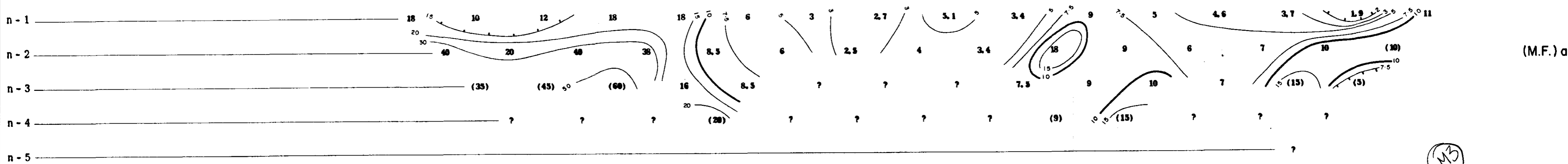
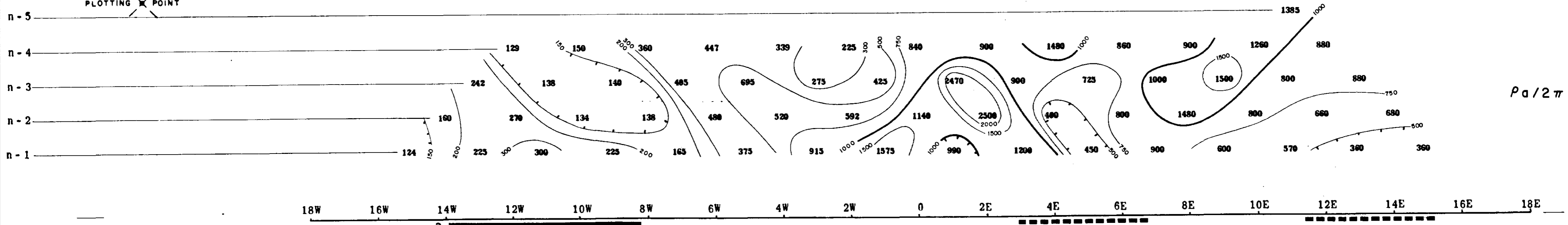
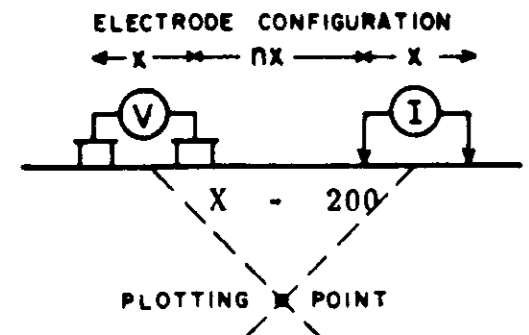

ANOMALOUS ZONE
POSSIBLE ANOMALOUS ZONE
NOTE
LOGARITHMIC CONTOUR INTERVAL

KENNCO EXPLORATIONS (WESTERN) LIMITED

DOROTHY CLAIM GROUP, HOGEM AREA—OMINECA MINING DIVISION, B.C.
Scale - One inch = 200 Feet

M3

FREQUENCY 31-5 CPS
DATE SURVEYED JUNE 1962
APPROVED
DATE 7/17/62

LINE NO. "O"

432

McPHAR GEOPHYSICS LIMITED INDUCED POLARIZATION AND RESISTIVITY SURVEY

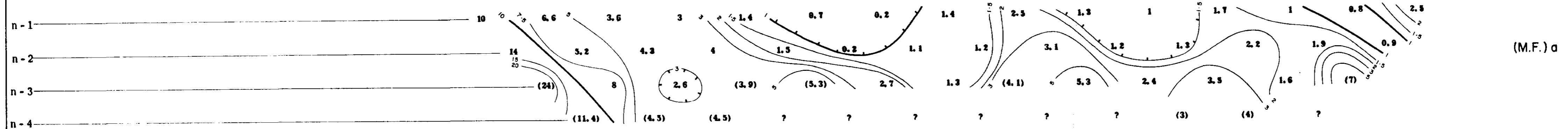
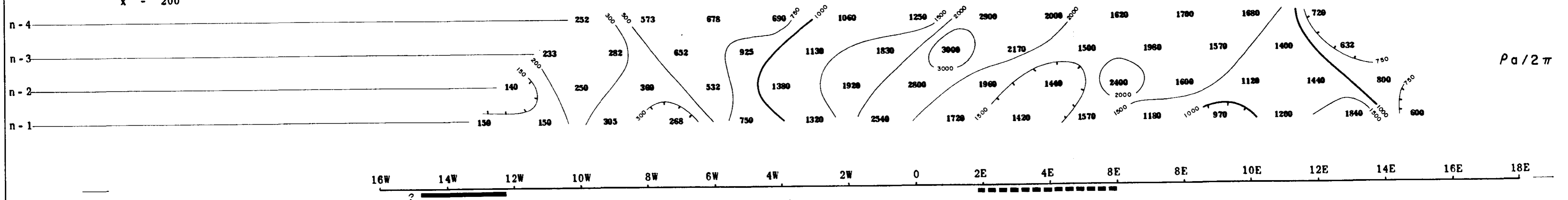
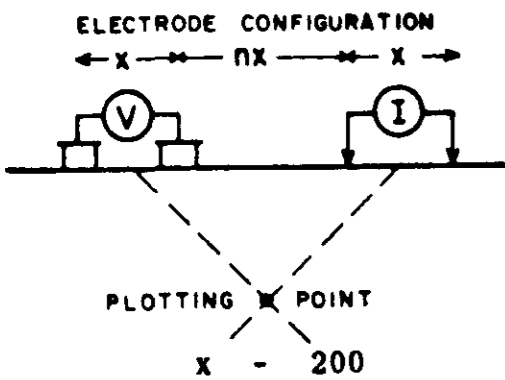

ANOMALOUS ZONE —————
 POSSIBLE ANOMALOUS ZONE - - - - -
 NOTE
 LOGARITHMIC CONTOUR INTERVAL

KENCO EXPLORATIONS (WESTERN) LIMITED
 DOROTHY CLAIM GROUP, HOGEM AREA—OMINECA MINING DIVISION, B.C.
 Scale—One inch= 200 Feet

FREQUENCY 31-5 CPS
 DATE SURVEYED JUNE 1962
 APPROVED PI
 DATE 7/17/62

LINE NO. 8N

M4

432

McPHAR GEOPHYSICS LIMITED

INDUCED POLARIZATION AND RESISTIVITY SURVEY

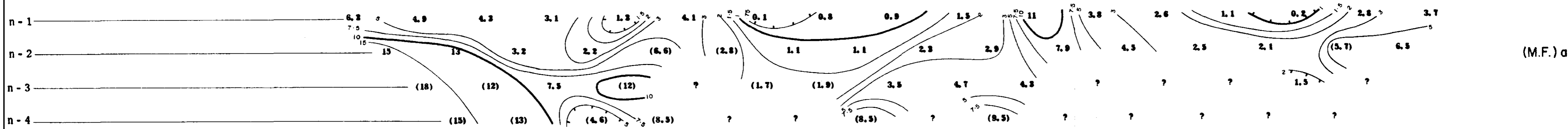
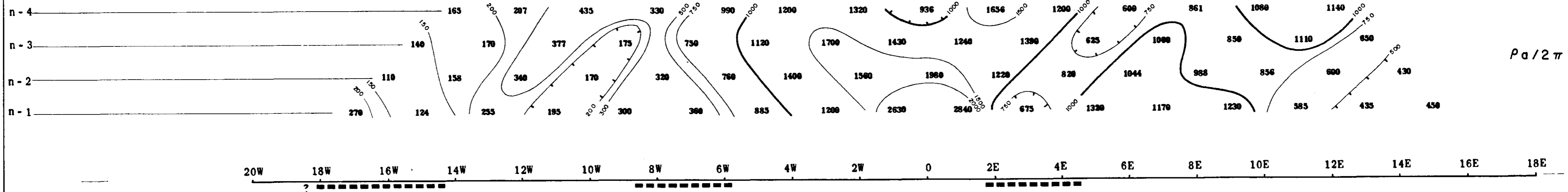
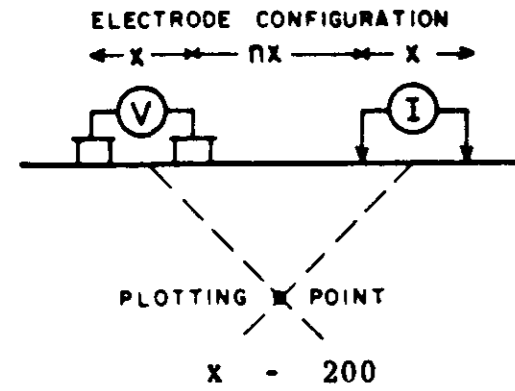

ANOMALOUS ZONE

POSSIBLE ANOMALOUS ZONE

NOTE
LOGARITHMIC CONTOUR INTERVAL

KENNCO EXPLORATIONS (WESTERN) LIMITED

DOROTHY CLAIM GROUP, HOGEM AREA—OMINECA MINING DIVISION, B.C.

Scale - One inch = 200 Feet

MS

FREQUENCY: 31-5 CPS

DATE SURVEYED: JUNE 1962

APPROVED:

DATE: 7/17/62

LINE NO. 16 N

432

McPHAR GEOPHYSICS LIMITED
INDUCED POLARIZATION AND RESISTIVITY SURVEY

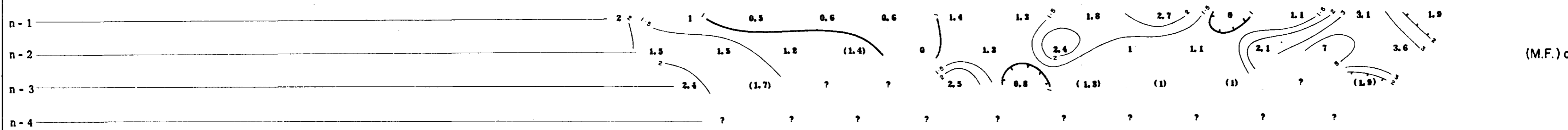
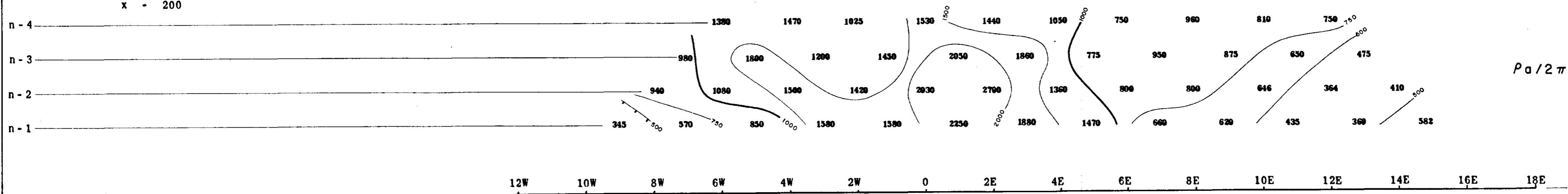
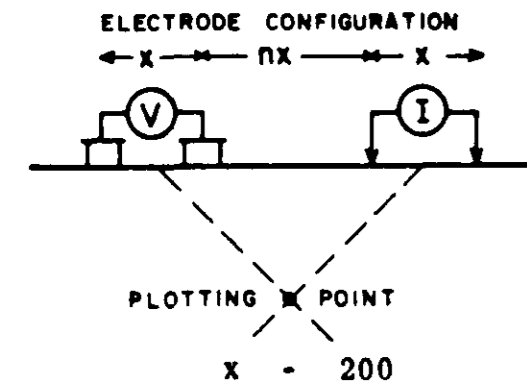

ANOMALOUS ZONE ———
POSSIBLE ANOMALOUS ZONE - - -
NOTE
LOGARITHMIC CONTOUR INTERVAL

KENNCO EXPLORATIONS (WESTERN) LIMITED
DOROTHY CLAIM GROUP, HOGEM AREA—OMINECA MINING DIVISION, B.C.
Scale—One inch= 200 Feet

M6

FREQUENCY 31-5 CPS
DATE SURVEYED JUNE 1962
APPROVED PI
DATE 7/17/62

LINE NO 24 N

432

McPHAR GEOPHYSICS LIMITED
INDUCED POLARIZATION AND RESISTIVITY SURVEY

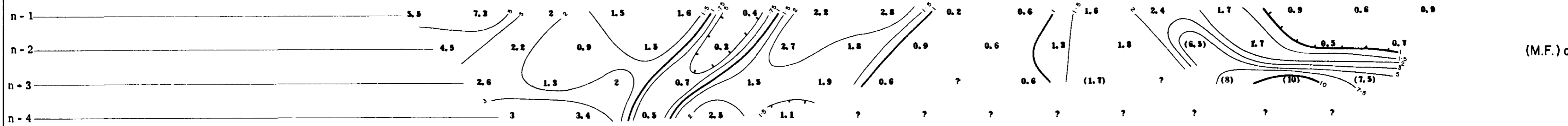
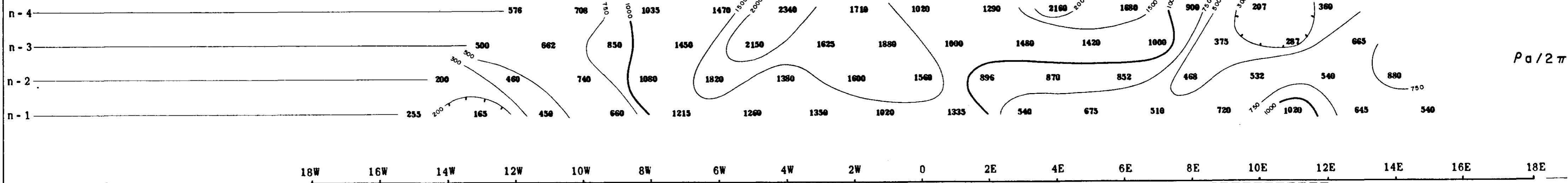
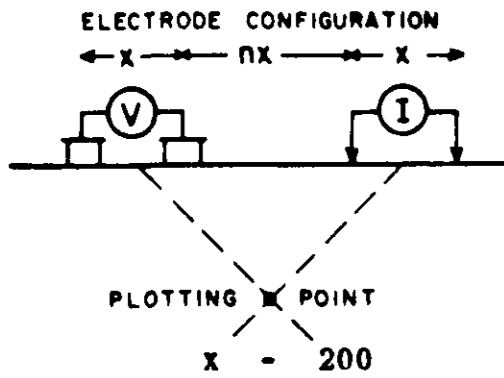

ANOMALOUS ZONE
 POSSIBLE ANOMALOUS ZONE
 NOTE
 LOGARITHMIC CONTOUR INTERVAL

KENNCO EXPLORATIONS (WESTERN) LIMITED
 DOROTHY CLAIM GROUP, HOGEM AREA—OMINECA MINING DIVISION, B.C.
 Scale—One inch= 200 Feet

M7

FREQUENCY: 31-5 CPS
 DATE SURVEYED: JUNE 1962
 APPROVED:
 DATE: 7/17/62

LINE NO. 44 N

MCPHAR GEOPHYSICS LIMITED
 INDUCED POLARIZATION AND RESISTIVITY SURVEY
 LOCATION MAP

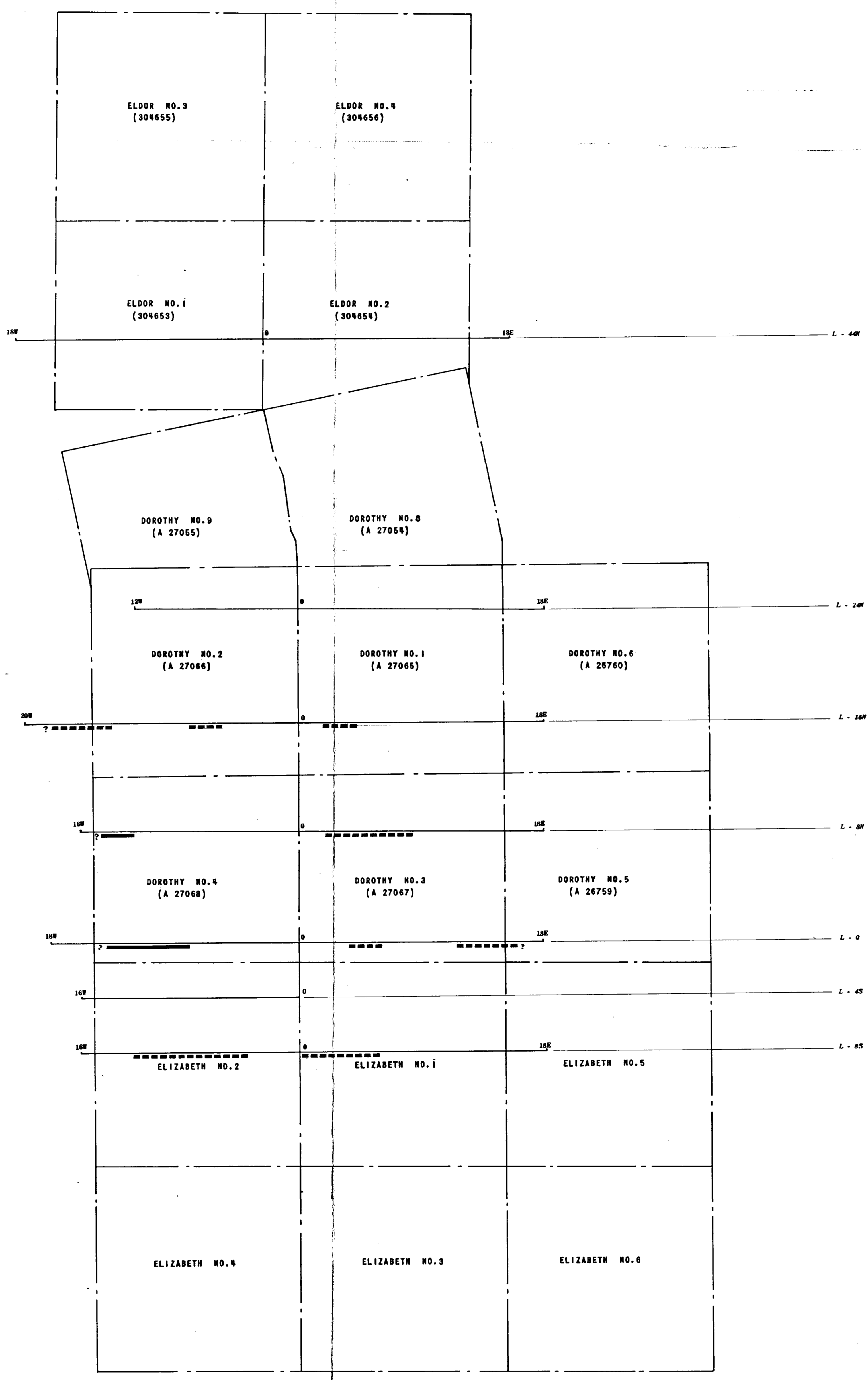

432
 (MB)

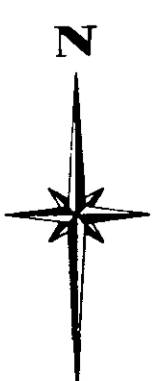
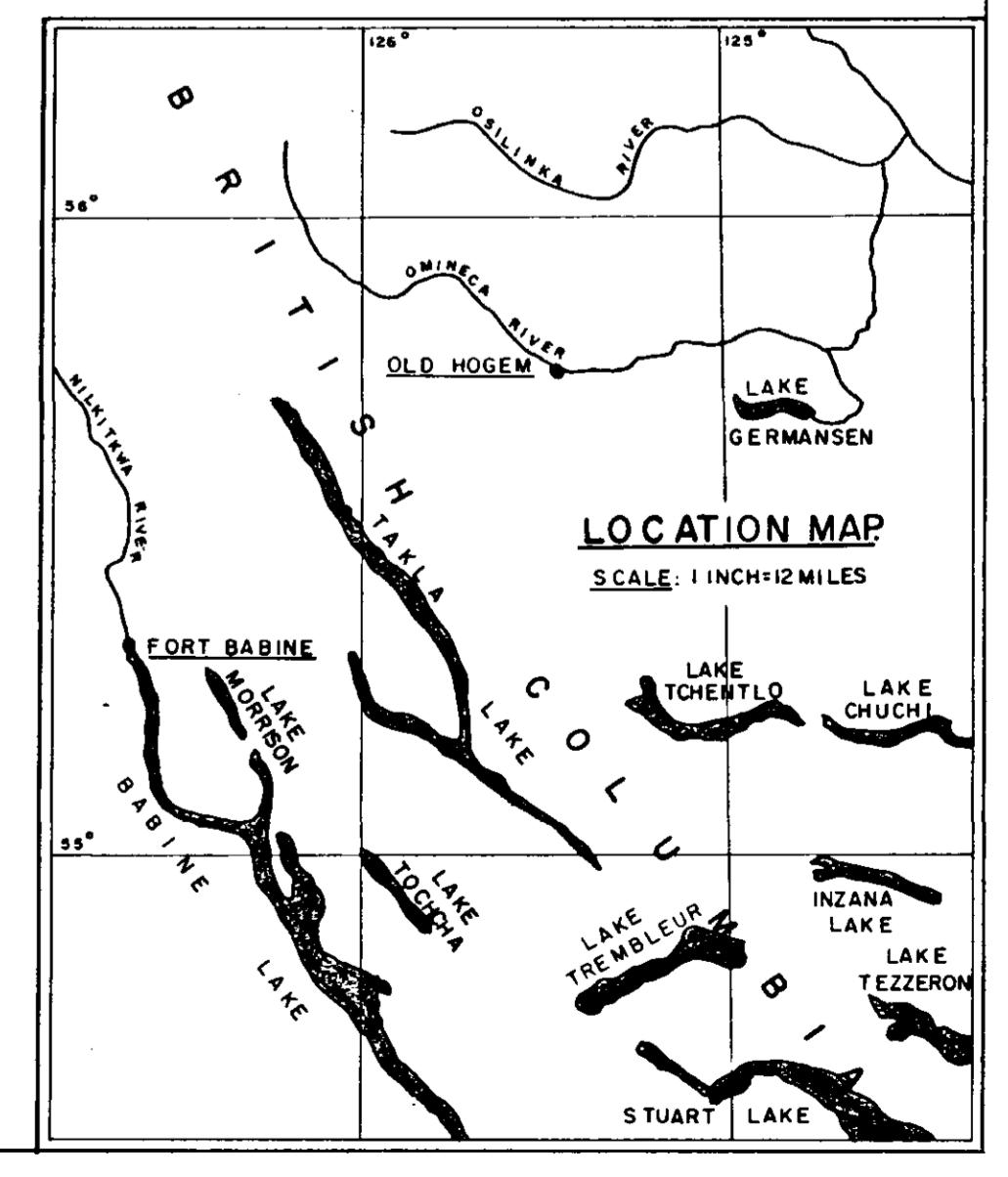

ANOMALOUS ZONE —————
 POSSIBLE ANOMALOUS ZONE - - - - -

KENNCO EXPLORATIONS (WESTERN) LIMITED

DOROTHY CLAIM GROUP
 HOGEM AREA - OMINECA MINING DIVISION, B.C.

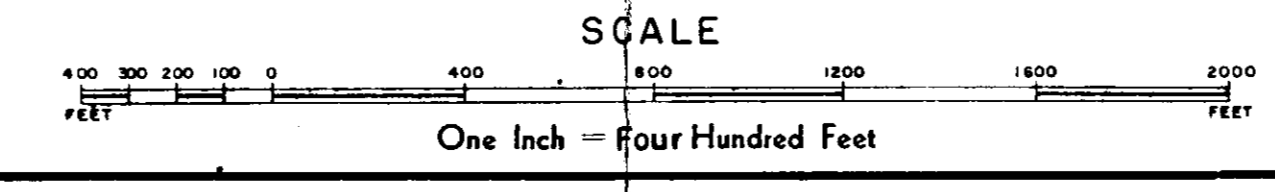

DRAWN: F.R.P.
 DATE: JULY 1962
 APPROVED: [Signature]
 DATE: 7/17/62