

1796

REPORT ON
INDUCED POLARIZATION SURVEYS
ON SOME BREN AND SUMMIT CLAIMS
MARGUERITE AREA, BRITISH COLUMBIA
ON BEHALF OF
MOROCCO MINES LIMITED

by

Jon G. Baird, B.Sc., P.Eng.

December 12, 1968

CLAIMS:

<u>Name</u>	<u>Record Number</u>
BREN 19 - 22	44919 - 44922
BREN 23 - 28	45199 - 45204
BREN 35	45211
BREN 37	45213
BREN 39	45215
BREN 41	45217
BREN 43	45219
BREN 45	45221
SUMMIT 1 - 8	28502 - 28509

LOCATION:

About 5 miles east of Marguerite, B.C.
Cariboo Mining Division
122° 52' ^{SE}_N

DATES:

November 26 - November 30, 1968
December 5 - December 9, 1968

TABLE OF CONTENTS

	<u>Page No.</u>
SUMMARY	
INTRODUCTION	1
GEOLOGY	2
PRESENTATION OF RESULTS	3
DISCUSSION OF RESULTS	4
CONCLUSIONS AND RECOMMENDATIONS	5

PLATES:

(in text)

Plate 1 - Property Location Map

(in envelope)

- 1 Plate 2 - Geophysical Results
Summit Claims 1" = 200'
- 2 Plate 3 - Chargeability Contour Plan
Bren Claims 1" = 400'
- 3 Plate 4 - Chargeability Profiles
Bren Claims 1" = 400'
- 4 Plate 5 - Resistivity Profiles
Bren Claims 1" = 400'

SUMMARY

The induced polarization survey on the SUMMIT claims has revealed an area of anomalous chargeability responses traversed by three grid lines 600' apart and as yet not delimited. The order of the induced polarization responses could be caused by a subsurface dissemination of about 2% by volume of metallicly conducting material.

The induced polarization survey on the BREN claims has revealed a large area not as yet delimited which exhibits very high chargeability response. The order of the induced polarization responses in this area could be caused by a dissemination of up to 8% by volume of metallicly conducting material.

The observed high I.P. responses on both claim groups could be caused by concentrations of metallicly conducting material such as sulphide mineralization, carbonaceous material, or magnetite in unknown relative proportions. Detail geochemistry, geology and possibly diamond drilling or trenching are recommended to attempt to determine the sources of the present high chargeabilities.

In the event that favourable results are obtained from the drilling or trenching on these targets, then additional I.P. surveying would be required to determine the extent of both anomalous zones and to provide guidance for the drilling programs.

REPORT ON
INDUCED POLARIZATION SURVEYS
ON SOME BREN AND SUMMIT CLAIMS
MARGUERITE AREA, BRITISH COLUMBIA
ON BEHALF OF
MOROCCO MINES LIMITED

INTRODUCTION

During the period from November 26 to November 30 and again from December 5 to December 9, 1968 a geophysical field party under the direction of Mr. Armidas Lefebvre executed an induced polarization survey on some Bren and Summit claims in the Marguerite area, British Columbia, on behalf of Morocco Mines Limited.

As shown on Plate 1, the two properties lie about two miles apart and each about five miles east of the Town of Marguerite. The actual claims covered, in whole or part, by the present survey are listed on the title page of this report and are shown on Plates 2 and 3. The Bren claims are held by Morocco Mines Limited and the Summit claims by Coast Silver Mines Limited.

Seigel Mk VI time domain (pulse-type) induced polarization equipment has been employed on this property. The transmitting unit had a rating of 2.5 kw and equal on and off times of 2.0 seconds. The receiving unit was a remote ground pulse type triggered by the rising and falling primary voltages set up in the ground by the transmitter. The integration of the transient polarization voltages takes place for 0.65 seconds after a 0.45 second delay time following the termination of the current-on pulse.



The purpose of an induced polarization survey is to map the subsurface distribution of metallicly conducting mineralization beneath the grids covered. In the present area such mineralization could include molybdenite, chalcopyrite, pyrite and other metallic sulphide minerals. As well, magnetite, graphite and other minerals can cause responses not always distinguishable from sulphide mineralization by the electrical characteristics alone.

The accompanying copy of H. O. Seigel's paper entitled "Three Recent Irish Discovery Case Histories Using Pulse-Type Induced Polarization" gives a description of the phenomena involved in this type of survey, the equipment employed, the field procedures and the nature of results obtained over various base metal ore bodies.

For the Bren claims, seven lines each approximately 6,000' in length and spaced 600' apart were cut oriented east-west. For the Summit claims, three lines each one mile in length were cut oriented east-west and also spaced 600' apart. Since the targets for the present surveys are large disseminated type ore bodies, the three electrode array with an electrode spacing of 400' was employed for reconnaissance purposes on both claim groups. In some areas of high chargeability responses, detailed observations were taken employing the three electrode array and electrode spacings of 200' and 100'. The nominal station interval was 200' although in areas where detailed measurements were taken the station interval was often 100'.

GEOLOGY

A description of the geology of the area including and surrounding the present claims is found on G.S.C. preliminary map sheet 93B "Quesnel Area" by H. W. Tipper, 1959. The areas covered by the present claims are



shown to be mostly underlain by Pleisococene and recent unconsolidated sediments. East of the claims lies a Mesozoic granitic intrusive which rises above the surrounding countryside and is called Granite Mountain (El. 4587'). West of the properties lies a north-south trending belt of Tertiary volcanic rocks while outcrops of Palaeozoic Cache Creek sediments are seen to the south. Sulphide mineralization has been observed in the Cache Creek rocks and in the Granite Mountain intrusive and the area has a possible potential as a locale for large tonnage, low grade copper-molybdenum deposits.

PRESENTATION OF RESULTS

Plate 2, on the scale of 1" = 200', shows the survey results for the Summit claims in plan and profile form. The chargeability contour plan shows the actual chargeability values for the 400' reconnaissance electrode spacing. A contour interval of 2.0 milliseconds has been chosen and areas exhibiting responses in excess of 8.0 milliseconds have been shaded. The chargeability and resistivity results are shown in profile form. The vertical scales for these profiles are 1" = 10.0 milliseconds for chargeability and 1" = 500 ohm-metres for resistivity.

Plate 3, on the scale of 1" = 400', is a chargeability contour plan for the Bren claim results. A contour interval of 10.0 milliseconds has been chosen for this map.

Plate 4 shows the chargeability results for the Bren claims in profile form. The vertical scale is 1" = 20.0 milliseconds and the plan scale is 1" = 400' although, to accommodate the profiles, the interline spacing is not to scale.

Plate 5, on a scale of 1" = 400', shows the resistivity profile for the Bren claims on a scale of 1" = 250 ohm-metres. The interline spacing is not to scale.



DISCUSSION OF RESULTS

Summit Claims

As shown on Plate 2, much of the chargeability response on these claims is below 6.0 milliseconds. This is a normal non-metallic background chargeability range to which a uniform distribution of 1% by volume of metallically conducting material would be expected to add another 6.0 milliseconds. An area exhibiting chargeabilities in excess of 8 milliseconds, of about 1200 ft. to 1400 ft. in width and striking slightly west of north, is to be seen on all three lines. The centre of this zone lies at about 32E on line 8N and 38E on line 4S. Since very low concentrations of copper and molybdenum sulphides of sufficient dimensions may be of economic significance, chargeabilities in excess of approximately 8.0 milliseconds may be of potential interest. The peak chargeability within this anomalous area is 19.5 milliseconds and occurs at 32 E on L 2 N. Detail traverses employing the 200' electrode spacings have been carried out on all three lines and indicate a general decrease in chargeability level for the shorter spacing. The depth to the upper surface of the body containing the anomalous material may be approximately 75' at the above location although further detail observations would be necessary to confirm this result. The area of the chargeability anomaly shows no distinct resistivity contrast with the surrounding area.

Bren Claims

As shown on Plates 3 and 4, the chargeability level for the western part of the Bren survey area is similar to the background chargeability level for the Summit claims; that is, generally below 8.0 milliseconds. The eastern portion of the survey area exhibits extremely high chargeabilities. A peak chargeability of 66.0 milliseconds was observed at station 72 E on



L 127 N, the most northerly line of the survey area. Chargeabilities of this amplitude could be caused by a subsurface content of about 8% or greater by volume of metallicly conducting material. Detailed profiles employing the 200' and 100' electrode spacings have been carried out on several profiles and are shown on Plate 4. These results on L 115 N, for example, show a general decrease in chargeability level with decreasing electrode spacing. Interpretation of these data reveals that the upper surface of the bulk of the polarizable material in this area could be approximately 50' from the ground surface, however, in some areas such as at 82 E the source material may come much closer to the surface; in other places it may be somewhat deeper. Since there is no distinct change in apparent resistivity with changing electrode spacing, interpretations of overburden depth are not possible.

There is, in a general way, a reciprocal relationship between high chargeability and low resistivity zones but this relationship is not faithful in detail. It is apparent, therefore, that the source of the I.P. response here is more disseminated rather than well interconnected metallic conduction.

CONCLUSIONS AND RECOMMENDATIONS

The induced polarization survey of the Summit claims has revealed a large area, not as yet completely outlined, which exhibits moderately high chargeability response. The character of the metallicly conducting material causing the anomaly is not known, however it could consist of about 2% by volume of sulphide mineralization. It is recommended that this area be subjected to geological and geochemical investigation and if indications seem favourable, diamond drilling should be considered. If drilling is desirable, a vertical hole to a minimum depth of 400' located at 32 E on L 2 N is recommended.

The induced polarization survey on the Bren claims has revealed a



wide area of high chargeability response extending off the present survey grid. The abrupt change in chargeability from the east to the west side of the grid and the large area of the anomaly would indicate that the causative body may be formational in nature. It may therefore consist of a rock type such as carbonaceous limestone or argillite which can be highly polarizable. The possibility that sulphide mineralization occurs within the present anomalous area cannot, however, be ruled out. The geology of the property should be studied in order to determine whether there is a distinct change in rock type corresponding with the change from low to high chargeability. If snow or overburden prohibits this, the present results should be compared with the geochemical data and trenching or diamond drilling should be considered. On the basis of the present results, trenching in the area of 82 E on L 115 N may possibly uncover some of the highly polarizable material. Since the high chargeability responses are so widespread it is not possible on the basis of the present data alone to choose an optimum location for diamond drilling although, if desired, the following exploratory hole would give a character sample of the causative material. Collar on line 115N at 84 E. Drill west along the line for 300 ft. at 45° inclination.

In the event that favourable results are obtained from the drilling or trenching on these targets then additional I.P. surveying would be required to determine the extent of both anomalous zones and to provide guidance for the drilling programs.

Respectfully submitted,

SEIGEL ASSOCIATES LIMITED



Jon G. Baird, B.Sc., P.Eng.
Geophysicist



Vancouver, B. C.
December 12, 1968

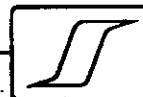

Harold O. Seigel

President,
Harold O. Seigel & Assoc., Ltd.,
Downsview, Ontario

Annual General Meeting,
Toronto, March, 1965

Three Recent Irish Discovery Case Histories Using Pulse-Type Induced Polarization

Transactions, Volume LXVIII, 1965, pp. 343-348

ABSTRACT

In the intensive Irish exploration program which has followed the discovery of the Tynagh deposit (Northgate Exploration, Ltd.) in 1962, three base metal discoveries have been made to date. These include the lead-zinc-silver deposits at Silvermines (Consolidated Mogul Mines, Ltd.), which are now being readied for production, the copper-silver deposit at Gortdrum (Gortdrum Mines, Ltd.) and the lead-zinc deposits near Keel (Rio Tinto-Zinc Ltd.). Each of these discoveries is the result of a combined geological-geochemical-geophysical exploration sequence in which pulse-type induced polarization surveys defined the precise location and lateral extent of the near-surface metallic sulphide mineralization and guided the initial drilling program. Whereas the Silvermines mineralization is, in part, composed of massive sulphides, the other two deposits are characterized by generally less than 5 per cent conducting sulphides and constitute an excellent demonstration of the unique merits of the pulse-type induced polarization system.

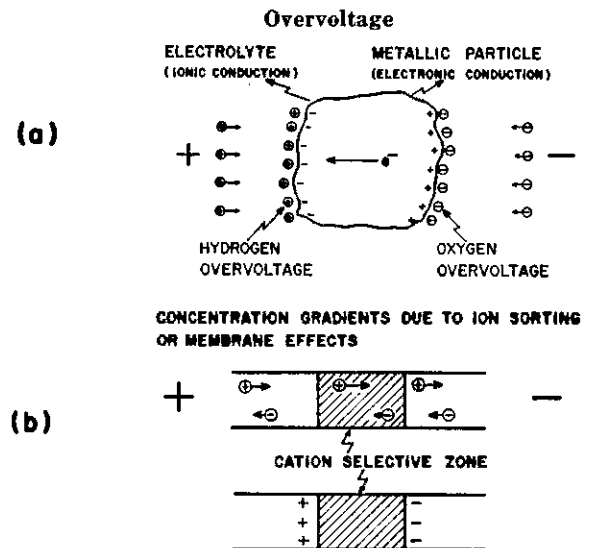

Figure 1.—Induced Polarization Agents.

Introduction

FOR the benefit of those who are unfamiliar with the induced polarization method in general or with the pulse-type method in particular, a few introductory remarks will be directed on the system employed in the present case histories. Those who wish a fuller treatment of the subject are directed to Seigel (1962),* which paper also includes an extensive list of references.

Induced polarization, in its broadest sense, means a separation of charge to form an effective dipolar (polarized) distribution of electrical charges throughout a medium under the action of an applied electric field. When current is caused to pass across the interface between an electrolyte and a metallic conducting body (Figure 1a) double layers of charge are built up at the interface, in the phenomenon known

to the electrochemists as "overvoltage." This is the phenomenon which can be utilized for the detection of the metallic conducting rock-forming minerals such as most sulphides, arsenides, a few oxides and, unfortunately, graphite. In addition, effective dipolar charge distributions occur to some extent in all rocks, due to ion-sorting or membrane effects in the fine capillaries in which the current is passing (Figure 1b). Induced polarization responses may therefore arise from metallic or non-metallic agencies. Fortunately, the latter generally fall within fairly low and narrow limits for almost all rock types, although there is still no reliable general criterion for differentiating overvoltage responses from graphite and metallic sulphides, or for distinguishing between the responses of one type of sulphide and another. Despite these limitations, the induced polarization method has amply demonstrated its value in mineral exploration since its initial development as a useful exploration tool in 1948. (Wait *et al.*, 1953).**

*Seigel, H. O., "Induced Polarization and its Role in Mineral Exploration," C.I.M. *Bulletin*, Vol. 55, No. 600, pp. 242-249; *Transactions*, Vol. LXV, pp. 151-158; 1962.

**"Overvoltage Research and Geophysical Applications," *Pergamon Press*, 1959, edited by J. R. Wait.

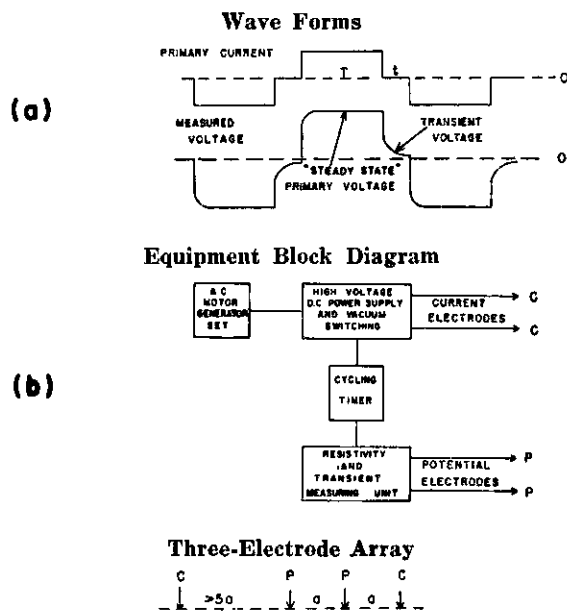

Figure 2.—The Pulse System.

Description of Method

For the present program, the pulse or time-domain system was employed. As shown on Figure 2a, the primary current wave form consists of square wave pulses of 1.5 seconds duration, separated by a 0.5-second gap and alternately reversed in direction. The polarization voltages established during the current-on time decay slowly during the current-off time. They are amplified, integrated over the current-off time and divided by the amplitude of the steady-state voltage measured during the current-on time. In this way, we determine the "chargeability;" i.e., the induced polarization property of the region under investigation. The units of chargeability are milliseconds. Normal (non-metallic) background chargeabilities in most rocks range from 1 millisecond to 5 milliseconds. A distribution of 1 per cent, by volume, of metallic conducting material of an average range of

particle size may be expected to increase the response level by about 3 milliseconds, which is readily visible.

The pulse system provides an absolute measurement of induced polarization; i.e., the significant measurement is made in the absence of the primary field. As such, it is inherently more sensitive than the frequency variation system, wherein two measurements are compared, both of which are made in the presence of the primary field. This is a critical consideration when mineralized bodies of low sulphide content, small size or great depth are being sought.

Figure 2b shows a block diagram of the apparatus employed and the electrode array used. The spacing "a" of the three-electrode array determines the effective depth of penetration of the survey and is selected to give adequate penetration to the depth desired. By varying the electrode spacing over an anomalous area and comparing the responses on the various spacings, one may obtain an estimate of the depth of burial of the source and its dip, etc.

A photograph of the type of apparatus employed on these surveys is shown in Figure 3. This is known as Seigel Mk V equipment and consists of the following major components: (a) a 1,200-watt A.C. motor-generator set, (b) a power control unit capable of supplying up to 1000 volts and 2 amperes D.C. output current and (c) a measuring unit. All of these items are packboard-mounted for maximum portability.

Figure 4 shows a typical instrumental set-up in Ireland. In the normal operating procedure, the electronic chassis are set up in a tent and cables are fed out to the line being surveyed. As the line crew is prepared, both mentally and by apparel, to work under all types of weather conditions, the survey is not stopped by rain, etc. This is important in Ireland, where, traditionally, there are no more than 60 rain-free days a year.

For the primary survey coverage on most properties, an electrode spacing of 200 to 300 ft. was generally employed, with a station interval of 200 ft. and a line separation of 300 to 500 ft. On anomalous areas located by the primary coverage, more closely spaced stations and lines are employed, as well as additional spacings to supply the detail necessary for subsequent drilling, etc.



Figure 3.—(above)—The Seigel Mk V Induced Polarization Unit.



Figure 4.—(right)—Typical Field Operational Base in Ireland.

Case Histories

In presenting the three case histories that follow, it must be made perfectly clear at the outset that these mineral discoveries are the product of teamwork, involving geological, geochemical and geophysical phases. It is on the basis of the first two phases that the areas for geophysical investigation have been selected. As the writer and his organization have been concerned only with the geophysical phase, this paper will, naturally, appear to emphasize it. The contribution of others to the broader exploration program must not be minimized, however.

In January, 1962, a large lead-zinc-silver deposit of a very unusual type was discovered near Tynagh, Co. Galway, in the Republic of Ireland. This deposit includes both a supergene enriched, partly oxidized upper zone and a sulphide primary zone and lies in dolomitic reef limestones of Carboniferous age near a fault contact with Devonian sandstones. Similar rock types and contacts occur in many parts of Ireland, so that an extensive program of exploration was initiated by a number of mining companies, starting in the summer of 1962. Although the pace has slowed up somewhat from the hectic days of 1962 and early 1963, this exploration program continues to the present time.

The usual exploration sequence, although not followed in detail by all companies, is as follows:

1

A selection of areas is made, based on the good government geological maps available. As nearly as possible, rock types and structures similar to those of the Tynagh deposit are sought. Those areas with known mineral showings are given high priority, of course.

2

The stream sediments in the drainage pattern are sampled and analyzed for significant amounts of copper, lead and zinc. Soil samples may also be taken, often on a regular grid basis, and analyzed. In this fashion, areas of abnormal metal content may be broadly defined. In detail, such geochemical sampling has often been hampered by man-made contamination and confused by soil transport by glacial, fluvial or human agencies.

3

Geophysical surveys, primarily the induced polarization type, are then conducted to map the subsurface distribution of sulphide mineralization and to provide guidance for a drilling program thereon.

This exploration program has already been remarkably successful, resulting, to date, in a new lead-zinc-silver mine-to-be at Silvermines, Co. Tipperary, for Consolidated Mogul Mines, Ltd., the probable copper-silver mine-to-be at Gortdrum, Cos. Tipperary and Limerick, for Gortdrum Mines, Ltd., and the interesting lead-zinc prospect at Keel, Co. Longford, for the Rio Tinto-Zinc group (Riofinex Ltd.). Figure 5 shows the location of the various recent mineral discoveries in Ireland. Despite a remarkable similarity in geological setting, the deposits are widely separated geographically, over a length of 80 miles, and no two are located on what can be called the same structure. This bodes well for the possibility of further discoveries being made in Ireland.

Each of the three case histories will be discussed below.

Silvermines Deposit

As the very name of the area implies, the Silvermines region had been known, for many centuries, as a locality mineralized with lead, zinc and silver. Metal production had taken place at several periods in the past, although at the time of the present investigations the mines were dormant. The very prominent Silvermines fault, striking about N 70°E, was known to be the significant control in the region, with the old mines and prospect pits scattered along its length over a distance of about 2 miles. Due to the past mining activity and transport by both drainage and man, a very extensive area gave rise to extremely high geochemical indications in lead and zinc. The induced polarization survey executed in late 1962 and early 1963 covered much of the concession area on 800-ft. sections and the geologically interesting portion thereof on 400-ft. sections. The three-electrode array, with 200-ft. electrode spacing, was employed on all lines, and spacings of 100 ft. and 400 ft. were also employed on the 400-ft. detail lines. In all, approximately 5 miles of the strike length of the Silvermines fault were covered by the present survey, 2½ miles in detail. At least ten distinct zones of abnormally high polarization were indicated, of which about half lay in the Silvermines mineralized belt and its extensions to the west and east.

One of these zones, designated the Garryard, has responded favourably to the subsequent drilling, resulting in the discovery of a mineable orebody.

To date, the announced proven tonnage figures include 12 million tons averaging approximately 8 per cent zinc, 3 per cent lead and 1 ounce of silver in the Garryard zone. This zone lies to the west of the zone from which the previous production had taken place.

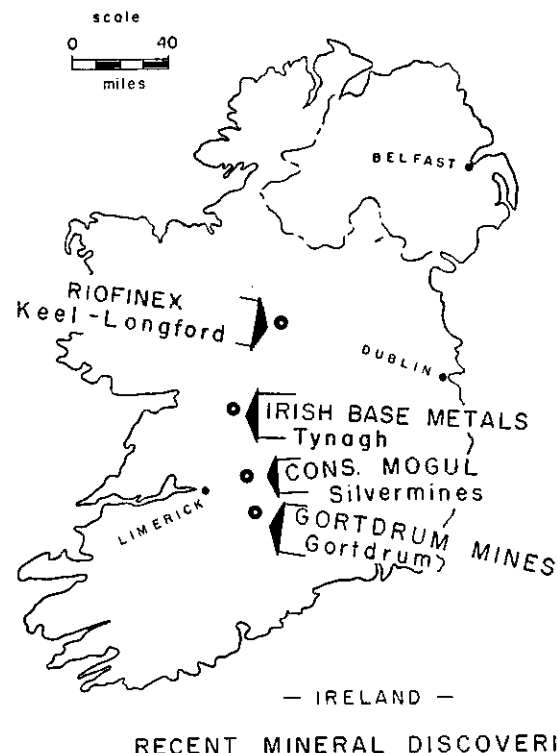

Figure 5.—Location Plan of Recent Mineral Discoveries in Ireland.

Figure 6 shows a typical discovery profile across the main ore zone, on the section 38,400E. The 200-ft. electrode spacing results, both chargeability and resistivity, are shown in profile form. The geologic section, as deduced from nine drill holes, is shown below the geophysical profiles. In a fashion almost identical

to that of the Tynagh deposit, the Silvermines ore-body is located in gently north-dipping dolomitic limestones adjacent to a fault contact with the Devonian "Old Red" sandstone. The mineralization here is composed of both massive and disseminated sulphides, with the former composed of a high percentage of pyrite. The mineralization is essentially conformable, in two distinct horizons, and is therefore flatly dipping except in the vicinity of the fault, where the dips are much steeper, perhaps due to "drag folding" on the fault.

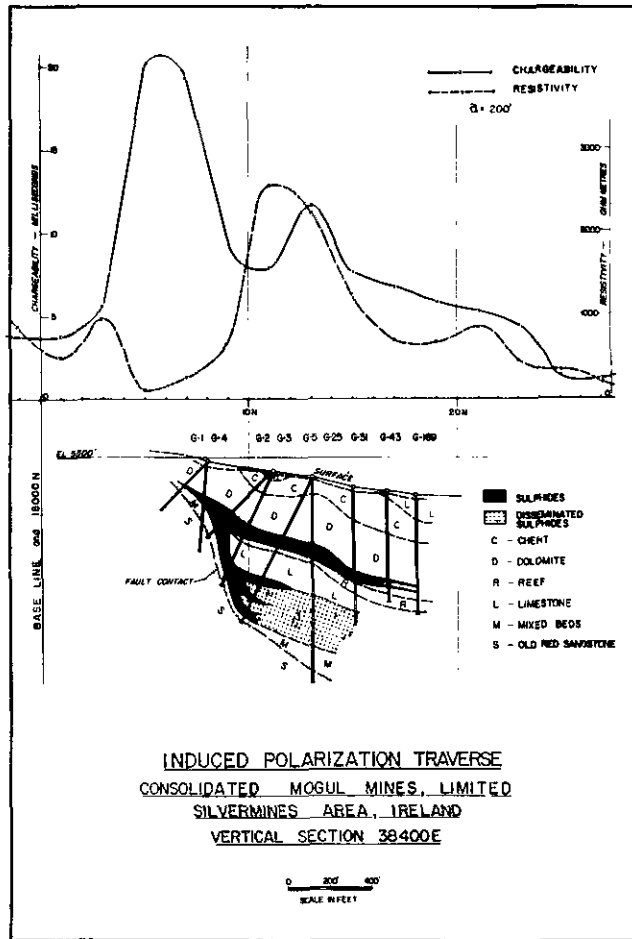

Figure 6.—Typical Discovery Traverse, Silvermines Deposit.

Because of the high pyritic content of the mineralization near the fault, along which it comes closest to the ground surface, we see both a marked increase in chargeability and a sharp decrease in resistivity in that vicinity. From a normal background of 2-4 milliseconds, the chargeability curve rises to a peak response of 20 milliseconds over the sub-outcrop of the body on this section. The subsidiary peak of about 12 milliseconds near 11N is believed to be due to disseminated pyrite in the chert horizon.

Figure 7 shows the multiple spacing chargeability results on the same section, using electrode spacing of 100, 200 and 400 ft. and the three-electrode array. On comparing the results with the various spacings, two items of interest may be noted; firstly, the progressive increase in peak amplitude with spacing, testifying to the increase of mineralization with depth, even down to a depth of 300 ft., and, secondly, the presence of buried material of high polarization at depth beneath section 10N to 18N on this line. The latter is undoubtedly due to the down-dip extension of the upper mineralized horizon, which is present at depths of 300 to 400 ft. over this region.

The induced polarization results on the Silvermines deposit were quite definitive and have provided good guidance for the exploratory drilling. It is true, however, that the massive sulphide portions of this deposit would be amenable to detection by the more conventional electrical methods, such as electromagnetic induction or resistivity. As such, it is not as good a test of the capabilities of the induced polarization method as are the two case histories which follow.

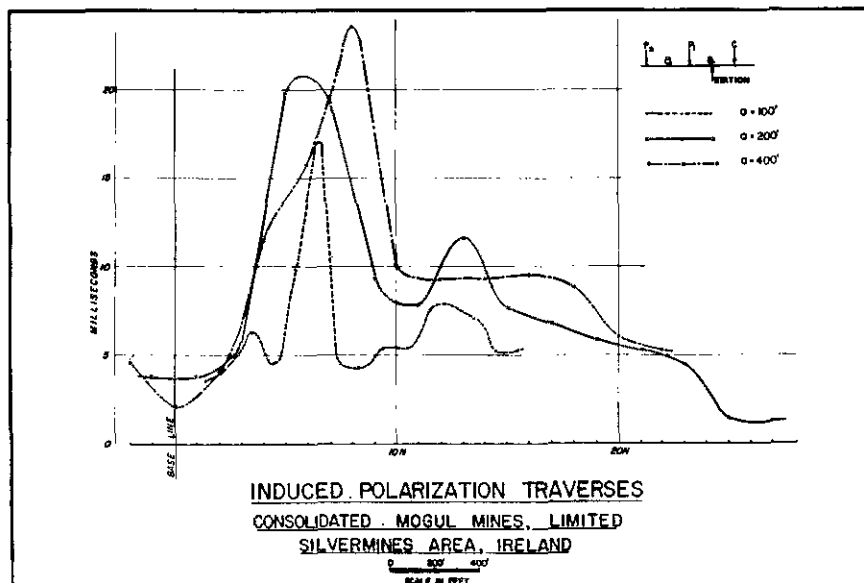

Figure 7.—Multiple Spacing Results, Silvermines Deposit.

Gortdrum Deposit

The Gortdrum area, near the mutual border of Cos. Limerick and Tipperary, was originally selected to cover the eastern extension of the former Oola Mines lead-zinc deposit, some 3 miles to the west. Regional geochemical sampling of the stream sediments in this area, followed by soil traverses, indicated a moderately strong copper soil anomaly. Induced polarization surveys were carried out in May, 1963, and January, 1964, leading to the localization of the sulphide mineralization associated with the geochemical anomaly. As there was a 300-ft. lateral displacement between the centers of the geophysical and geochemical indications and the surface topography is very gentle, it was initially queried as to whether the two indications

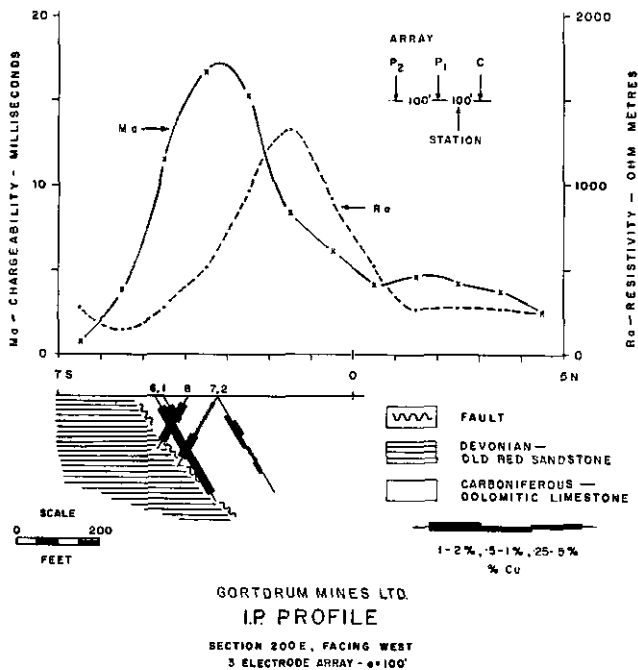

Figure 8.—Typical Discovery Traverse, Gortdrum Deposit.

were related. The subsequent drilling has fully confirmed the geophysical predictions.

On the initial two geophysical programs, the three-electrode array with 100-ft. spacing was employed, as a relatively shallow source of the geochemical anomaly was expected. The survey lines were at 200-ft. intervals. Figure 8 presents a typical discovery traverse, showing both the chargeability and resistivity profiles as well as the corresponding geologic section. A peak chargeability of about 17 milliseconds is observed, rising from the normal background of 2-4 milliseconds. There is no resistivity expression of the mineralized zone, lying as it does on the flank of a high-resistivity area.

Figure 9 shows the chargeability profiles for electrode spacings of 50, 100 and 200 ft. Points of special interest deduced from these profiles include the following:

1.—The extremely sharp cut-off of the high chargeability levels on the south side of the area and the gradual drop-off in level on the north side. This was inconsistent with the thought of a bedded-type deposit conformable with the limestones, which are known to dip flatly to the south. A fault or other contact was postulated, dipping steeply, probably to the north. The initial drill holes on the section (Nos. 1, 2 and 6) were drilled to the north on the original geologic-dip premise, but the later holes (e.g., Nos. 7 and 8) have all been drilled to the south.

2.—The high-polarization material does not quite outcrop, but still comes within about 25 ft. of the ground surface across a width of about 200 ft., including two or more lenses. This material extends to at least 200 ft. in depth.

The actual drilling results confirm the presence of a zone of finely disseminated chalcocite and bornite, with very minor chalcopyrite, in dolomitic limestones. The mineralization is somewhat erratically distributed but, in general, increases as one approaches a north-

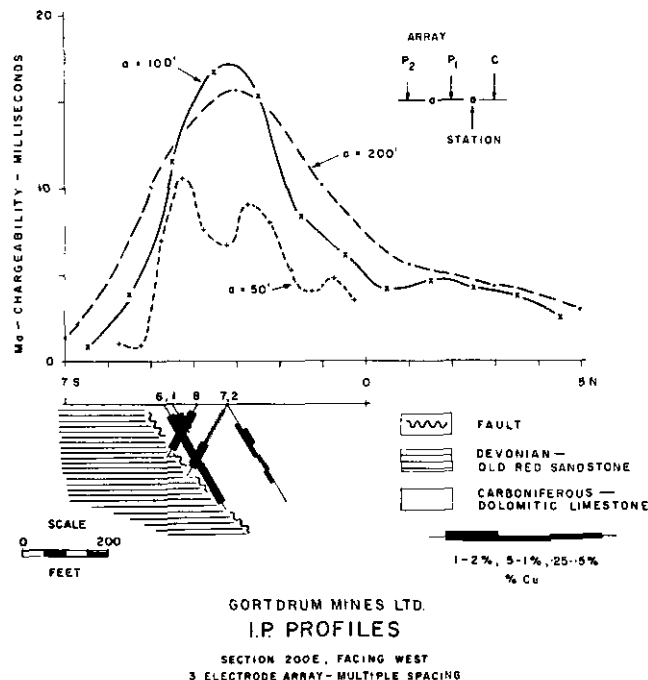

Figure 9.—Multiple Spacing Results, Gortdrum Deposit.

dipping fault, which brings the limestones into contact with the Devonian Old Red sandstones. This fault has been found to strike about N 70°E. Geologically, therefore, this environment is almost identical to that of the Tynagh and Silvermines deposits. The mineralization in the Gortdrum area is quite different, however, both in type and amount. The average grade of the deposit is less than 2 per cent copper, with about 0.65 ounce of silver for each 1 per cent copper (although considerable potential open-pit tonnage may exist), so that the average sulphide content, by volume, is 3 per cent or less. The high chargeability responses observed over this deposit are a remarkable tribute to the sensitivity of the pulse-type induced polarization method, particularly when dealing with truly disseminated-type sulphide mineralization with a small average particle size.

As development drilling is still in progress on this deposit, no over-all grade or tonnage figures have as yet been released.

Keel Deposit

The deposits near Keel and Longford, Co. Longford, occur on a known limestone-sandstone contact, which is, no doubt, one of the reasons why exploration interest was attracted thereto. Soil sampling traverses by Riofinex Ltd., an exploration subsidiary of Rio Tinto-Zinc Corporation, Ltd., established the presence of anomalous lead and zinc concentrations. A horizontal-loop electromagnetic survey was initially executed in another attempt to determine the source of the geochemical indications, but with negative results. This was followed by induced polarization surveys in November and December, 1962. The three-electrode array, with an electrode spacing of 200 ft., was employed on the reconnaissance survey. Anomalous chargeability zones were indicated and exploratory drilling commenced shortly thereafter. Although no publication of results has been made, they are of some potential interest, as drilling has continued, at intervals, to the present time.

Figure 10 shows a typical section across the prospect, presenting the geophysical and geochemical results in profile form, as well as the geological section interpreted from three holes. The relationship between the mineralized horizon, the geophysical peak and the geochemical peaks is a matter of considerable interest. The sub-outcrop of the mineralized horizon and the geophysical peak are in good agreement (see also Figure 11). The lead peak is displaced about 400 - 500 ft. down slope to the south. The zinc peak

is displaced still another 300 ft. to the south. The actual topographic slope is only 1-2 degrees to the south, so that this displacement is difficult to account for on the basis of soil creep. There is only a minor resistivity depression associated with the mineralization, indicating why the electromagnetic survey failed to give any positive response to it.

The mineralization itself is primarily sphalerite, with some galena and, on the average, less than 5 per cent pyrite. It is found to lie primarily in a dolomite horizon adjacent to a contact with sandstone. In this case, the contact may be largely a depositional one and not due to a fault. Mineralization occurs to a minor extent in the sandstone as well.

Figure 11 shows the chargeability results of the multiple spacing profiles on this section. Spacings of 50, 100 and 200 ft. were used. The progressive step-out of the peak values to the south with the increase in electrode spacing indicates the effect of the relatively flat dip to the south of the mineralization. The sub-outcrop of the mineralization is near station 26N, at a depth of less than 25 ft. As hole K3B, only 100 ft. away, intersected almost 60 ft. of overburden one must conclude that the bedrock surface is rather irregular in this area. The peak chargeability of 24 milliseconds would suggest a metallic conductor content of the order of 6 to 12 per cent, by volume, in this area.

It is the writer's hope that he has not given the impression that every induced polarization anomaly in Ireland inevitably defines an orebody, or that every exploration venture there is crowned with success. Aside from effects due to the many man-made conductors, such as grounded power lines, rabbit fences and buried pipe lines, there are certain carbonaceous sediments, in particular the Calp limestone, which overlies the ore-bearing dolomitic limestone in some places, which yield high polarization responses. Fortunately, the areal distribution of the latter is usually broad enough to suggest a formational origin. Also, fortunately, the Calp is, stratigraphically, sufficiently well separated from the ore-bearing limestones so that the effect from these two horizons may be resolved. With the geological and geochemical information available, one can usually determine whether a particular induced polarization indication warrants investigation by drilling. Despite its limitations, the pulse-type induced polarization method has well demonstrated its application to a broad range of base metal exploration problems in Ireland.

Acknowledgments

The writer wishes to express his thanks to Consolidated Mogul Mines, Ltd., and Dr. W. W. Weber, to Gortdrum Mines, Ltd. and Dr. D. R. Derry, and to Rio Tinto-Zinc Corp. Ltd. and Mr. Jocelyn Pereira, for their kind permission to present the geophysical and other details relating to their respective mineral discoveries. In addition, the writer wishes to acknowledge the able assistance of the staff of Canadian Aero Mineral Surveys, Ltd., with which our company, Harold O. Seigel & Associates Ltd., has acted on a co-operative basis in Ireland.

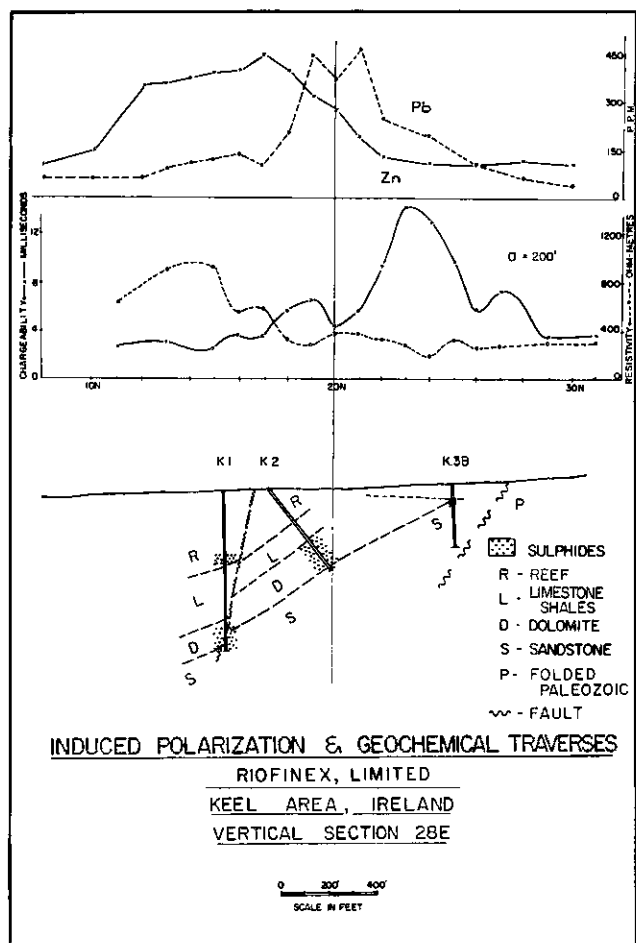

Figure 10.—Typical Discovery Traverse, Keel Deposit.

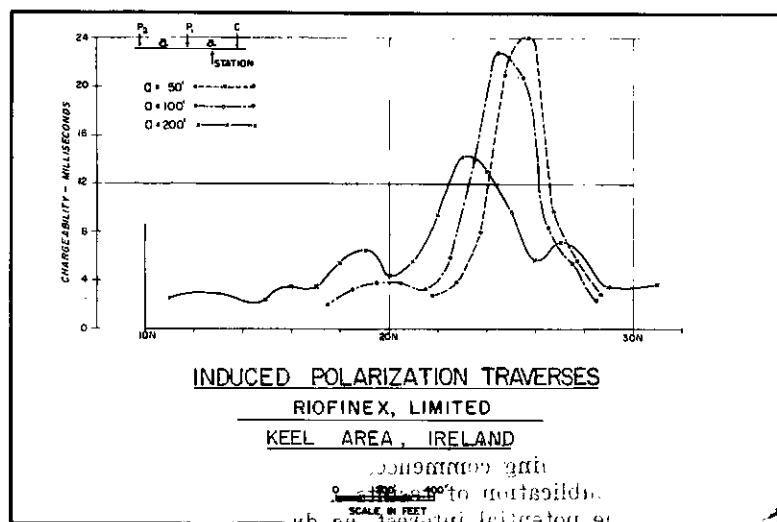

Figure 11.—Multiple Spacing Results, Keel Deposit.

(Reprinted from The Canadian Mining and Metallurgical Bulletin, November, 1965)

Printed in Canada

DOMINION OF CANADA:
PROVINCE OF BRITISH COLUMBIA.
TO WIT:

In the Matter of a geophysical survey on behalf of
Morocco Mines Limited

I, **E.M. Flett for Seigel Associates Limited**

of **750 -- 890 West Pender St., Vancouver**

in the Province of British Columbia, do solemnly declare that **an induced polarization survey has been executed on some BREN and SUMMIT claims in the Marguerite area, British Columbia between November 26 - 30 and December 5 - 9, 1968. The following expenses were incurred:**

(1) Wages			
A. Lafabvre	11 days @ \$35/day	\$385.00	
R. Mischler	11 days @ \$27.50/day	302.50	
M. Bisang	11 days @ \$27.50/day	302.50	
D. Reid	11 days @ \$27.50/day	<u>302.50</u>	\$1,292.50
(2) Transportation & Shipping			303.86
(3) Food & Living Expenses			358.85
(4) Consulting Fees			
8 days @ \$200.00/day		\$1600.00	
3 days @ \$130.00/day		390.00	<u>1,990.00</u>
			\$3,945.21

And I make this solemn declaration conscientiously believing it to be true, and knowing that it is of the same force and effect as if made under oath and by virtue of the "Canada Evidence Act."

Declared before me at the **City**
of **Vancouver**, in the
Province of British Columbia, this **19**
day of **December, 1968**, A.D.

E.M. Flett

[Signature]

A Commissioner for taking Affidavits for British Columbia or
A Notary Public in and for the Province of British Columbia.

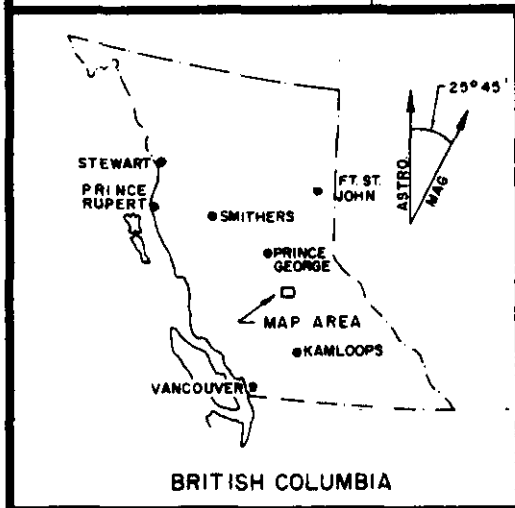
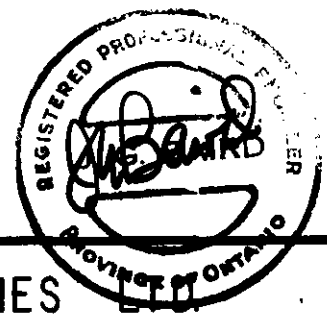
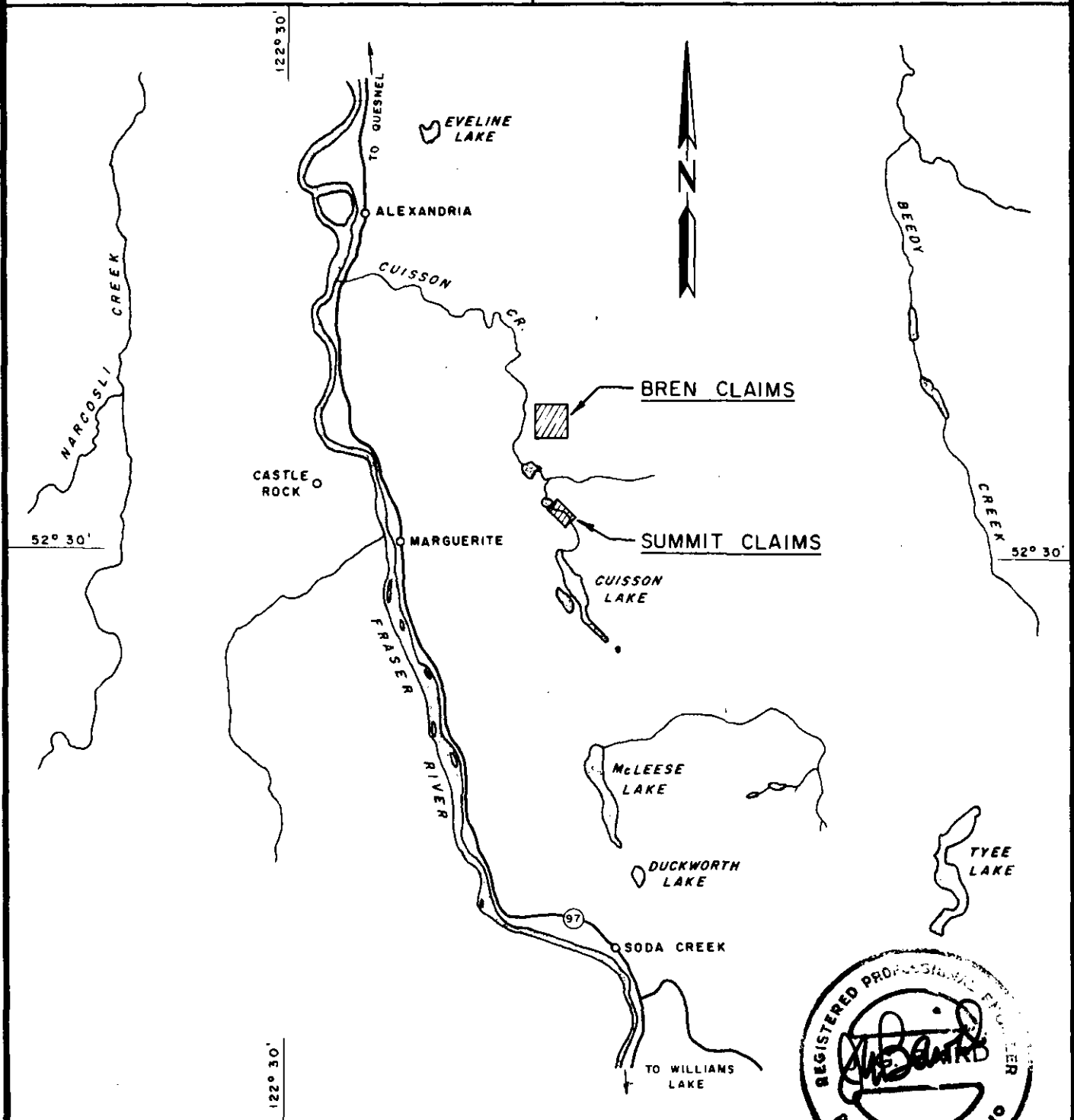

MOROCCO MINES

LOCATION MAP

BREN AND SUMMIT CLAIMS

MARGUERITE AREA, BRITISH COLUMBIA



SURVEY BY
SEIGEL ASSOCIATES LIMITED
DECEMBER 1968

PLATE 1

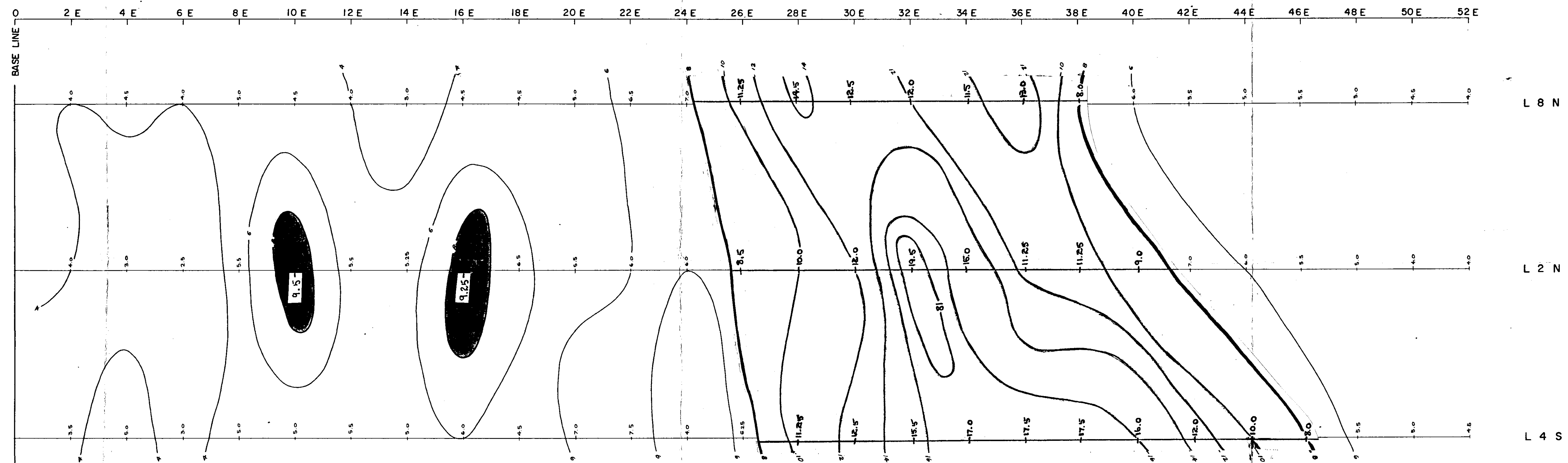

CHARGEABILITY CONTOUR PLAN

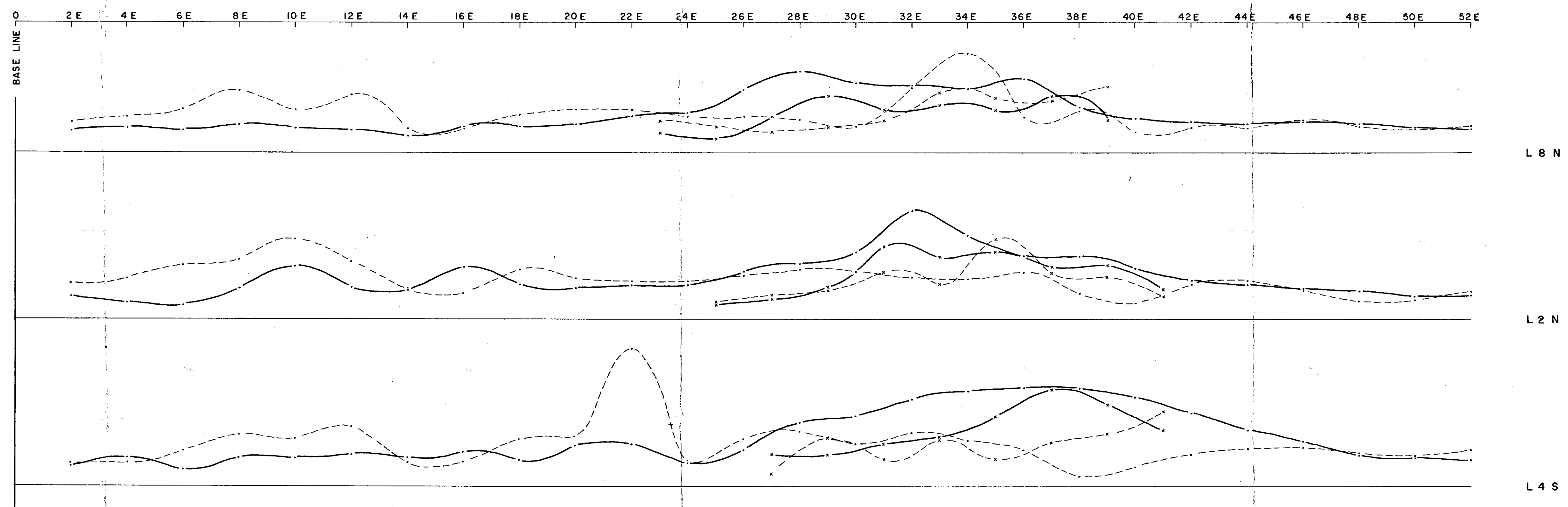

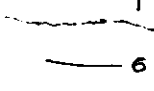

CHARGEABILITY AND RESISTIVITY PROFILES

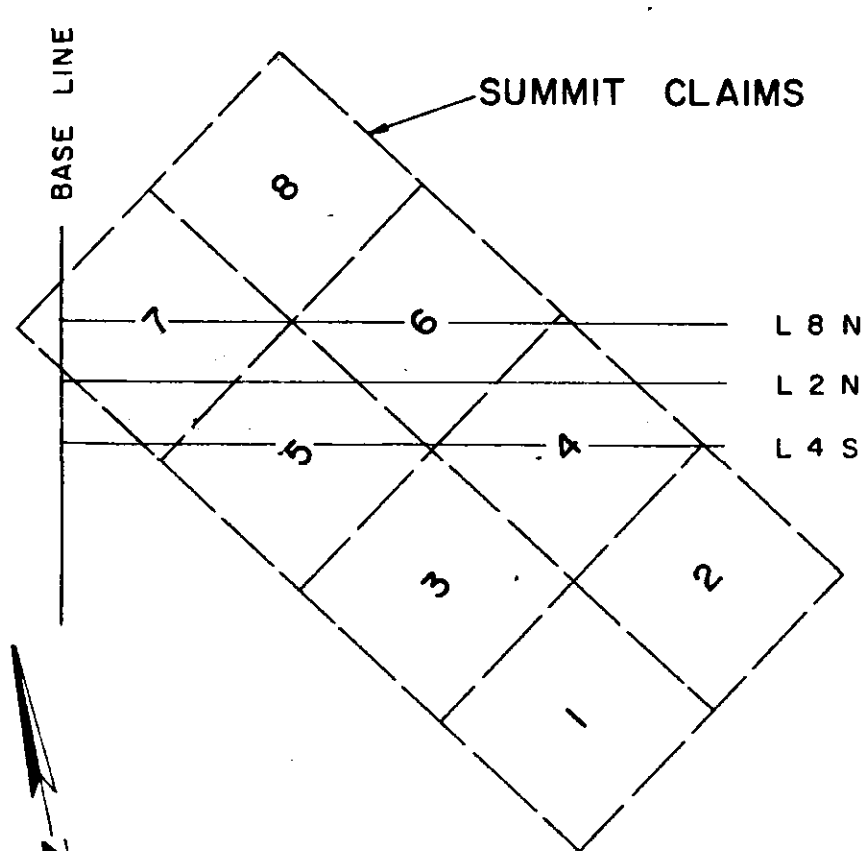
LEGEND:
 LINE TRACE WITH CHARGEABILITY VALUE IN MILLISECONDS
 4, 6, 8, 10, 12, 14, 16 AND 18 MILLISECONDS CONTOURS

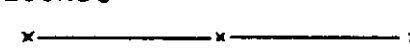
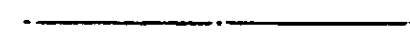
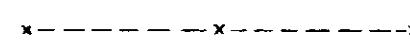

CLAIMS MAP
 SCALE: 1" = 1500'

LEGEND:
 CHARGEABILITY, SCALE: 1" = 10 MILLISECONDS
 ELECTRODE SPACING: \circ = 200' 
 \circ = 400' 
 RESISTIVITY, SCALE: 1" = 500 OHM-METRES
 ELECTRODE SPACING: \circ = 200' 
 \circ = 400' 

Division of
 Mines and Technical Surveys
 Geological Survey of Canada
 NO. 1796

PLATE 2 **1796**
 MOROCCO MINES LTD.
 MARGUERITE AREA, BRITISH COLUMBIA
 SUMMIT CLAIMS
 INDUCED POLARIZATION SURVEY

TO ACCOMPANY A GEOPHYSICAL REPORT BY
 J. G. BAIRD DATED DECEMBER 12, 1968

SCALE: 1" = 200'
 SURVEY BY SEIGEL ASSOCIATES LIMITED
 DECEMBER, 1968

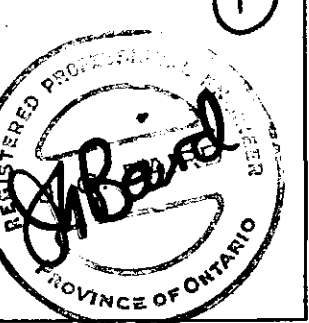

22 E 26 E 30 E 34 E 38 E 42 E 46 E 50 E 54 E 58 E 62 E 66 E 70 E 74 E 78 E 82 E 86 E 90 E 94 E 98 E 102 E 106 E

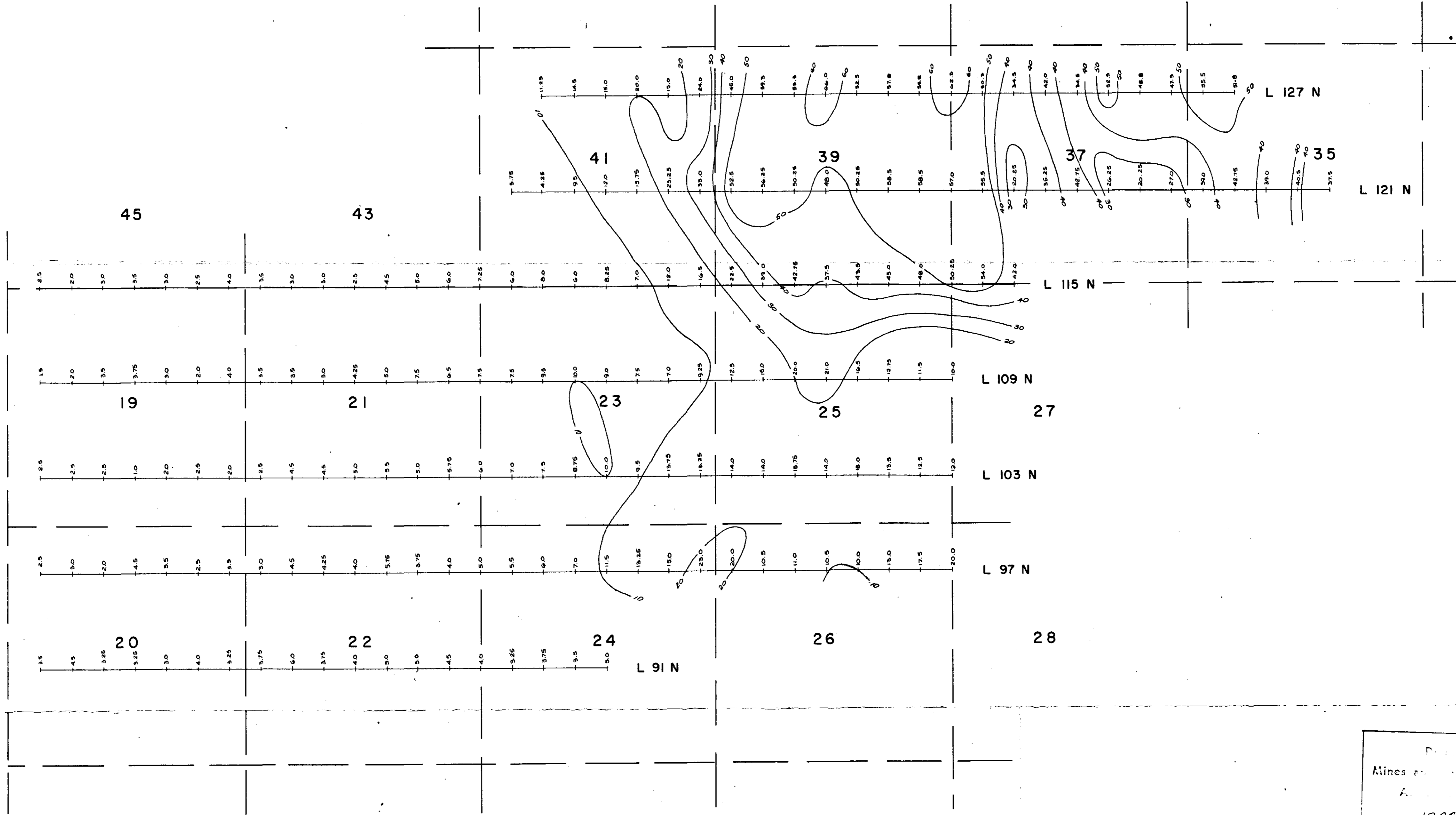

LEGEND:

- LINE TRACE WITH VALUES IN MILLISECONDS
- 10, 20, 30, 40 AND 50 MILLISECOND CONTOURS

NOTES:
THREE ELECTRODE ARRAY
ELECTRODE SPACING: a = 400'

Division of
Mines and Technical Resources
No. 1796 Rev. 2

PLATE 3 **1796**
MOROCCO MINES LTD.
MARGUERITE AREA, BRITISH COLUMBIA
BREN GROUP CLAIMS
INDUCED POLARIZATION SURVEY
CHARGEABILITY CONTOUR PLAN
SCALE: 1" = 400'
SURVEY BY SEIGEL ASSOCIATES LIMITED
DECEMBER, 1968

TO ACCOMPANY A GEOPHYSICAL REPORT BY
J.G. BAIRD DATED DECEMBER 12, 1968



22E 26E 30E 34E 38E 42E 46E 50E 54E 58E 62E 66E 70E 74E 78E 82E 86E 90E 94E 98E 102E 106E

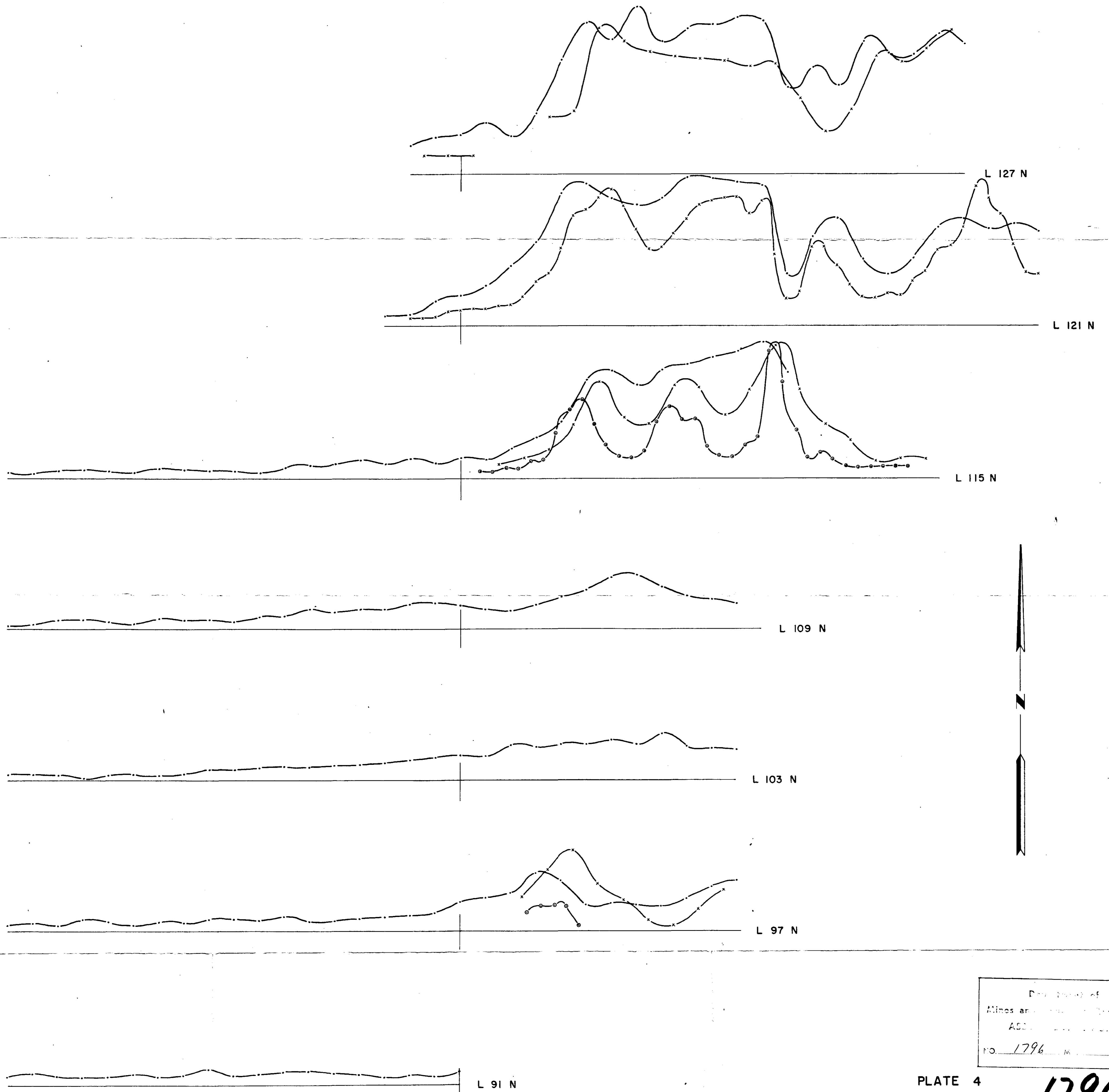

LEGEND:
 CHARGEABILITY, SCALE: 1" = 20 MILLISECONDS
 ELECTRODE SPACING: \circ = 400' \times \times \times \times
 \circ = 200' \times \times \times \times
 \circ = 100' \circ \circ \circ \circ

NOTES:
 THREE ELECTRODE ARRAY
 ELECTRODE SPACINGS AS INDICATED
 INTERLINE SPACING NOT TO SCALE

TO ACCOMPANY A GEOPHYSICAL REPORT BY
 J.G. BAIRD DATED DECEMBER 12, 1968

Department of
 Mines and Geology
 ASST. REGISTRAR
 No. 1796 M. 3

PLATE 4

MOROCCO MINES LTD. 1796
 MARGUERITE AREA, BRITISH COLUMBIA
 BREN GROUP CLAIMS
INDUCED POLARIZATION SURVEY
 CHARGEABILITY PROFILES
 SCALE: 1" = 400'

SURVEY BY SEIGEL ASSOCIATES LIMITED
 DECEMBER, 1968

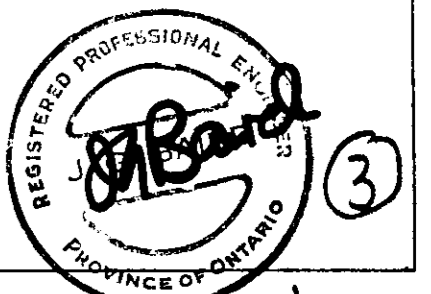

22E 26E 30E 34E 38E 42E 46E 50E 54E 58E 62E 66E 70E 74E 78E 82E 86E 90E 94E 98E 102E 106E

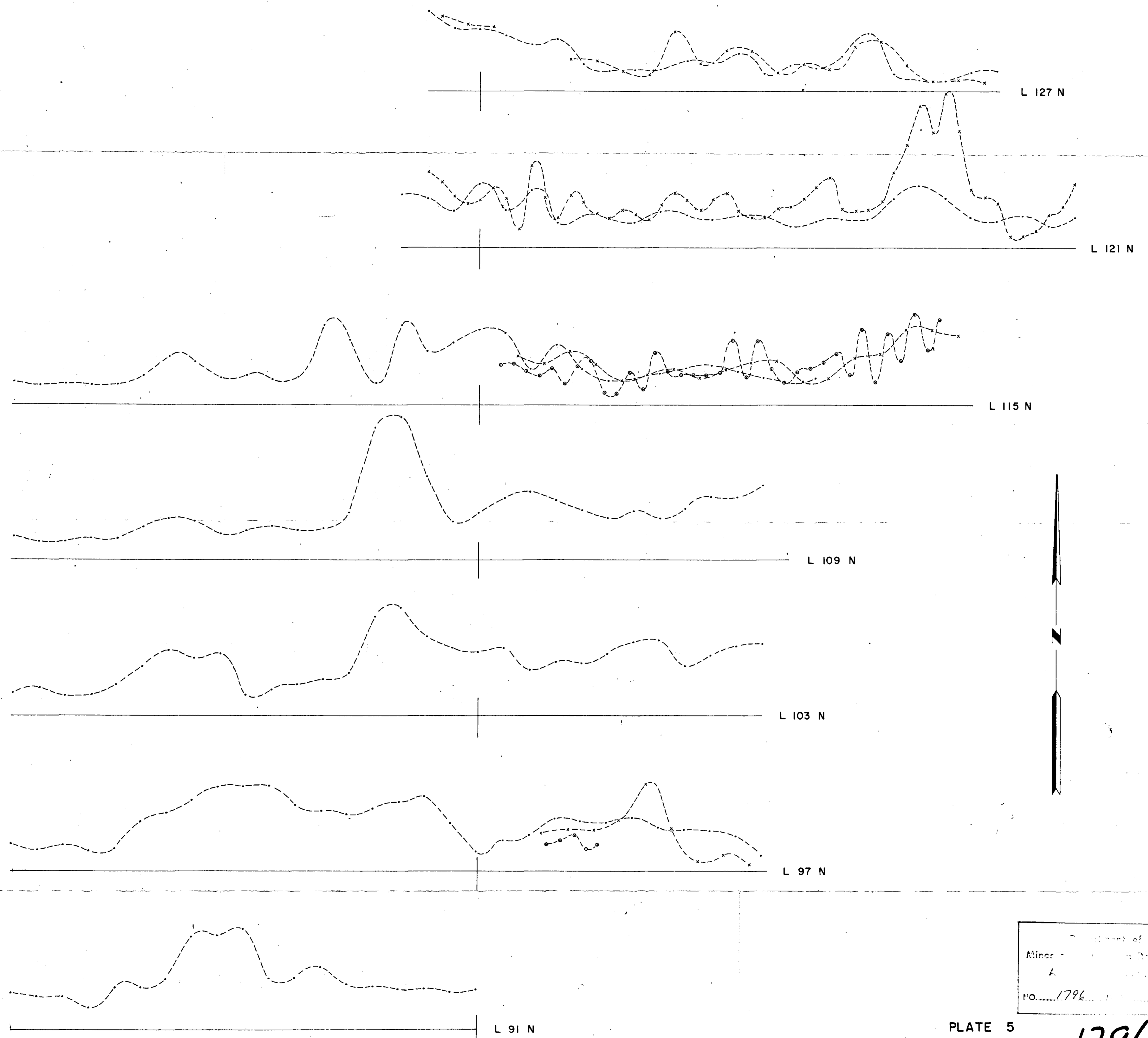

LEGEND

RESISTIVITY SCALE: 1" = 250 OHM-METRES

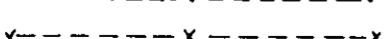
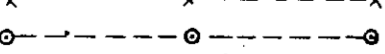
ELECTRODE SPACING
 o = 400' 
 x = 200' 
 o = 100' 

NOTES:

THREE ELECTRODE ARRAY
 ELECTRODE SPACINGS AS INDICATED
 INTERLINE SPACING NOT TO SCALE

Department of
 Mines and Technical Surveys
 No. 1796

PLATE 5

MOROCCO MINES LTD. 1796
 MARGUERITE AREA, BRITISH COLUMBIA
 BREN GROUP CLAIMS

INDUCED POLARIZATION SURVEY
 RESISTIVITY PROFILES
 SCALE: 1" = 400

TO ACCOMPANY A GEOPHYSICAL REPORT BY
 J.G. BAIRD DATED DECEMBER 12, 1968

SURVEY BY SEIGEL ASSOCIATES LIMITED
 DECEMBER, 1968

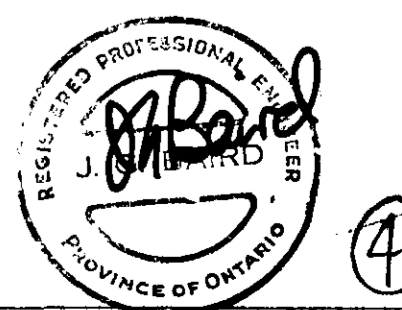

4