

REPORT ON THE
INDUCED POLARIZATION
AND RESISTIVITY SURVEY
ON THE
KLI NO.1 GROUP AND NO. 2 GROUP
KLIYUL CREEK AREA,
OMINECA MINING DIVISION, B. C.
FOR
KENNCO EXPLORATIONS (WESTERN) LIMITED

BY
MARION A. GOUDIE, B.Sc.
AND
PHILIP G. HALLOF, Ph.D.

NAME AND LOCATION OF PROPERTY
KLI NO.1 GROUP AND NO. 2 GROUP, KLIYUL CREEK AREA,
OMINECA MINING DIVISION, B. C. 56°N, 126°W - NE, SE
DATE STARTED - AUGUST 14, 1971
DATE FINISHED - AUGUST 28, 1971

TABLE OF CONTENTS

<u>Part A:</u>	Notes on theory and field procedure	9 pages	
<u>Part B:</u>	Report	10 pages	<u>Page</u>
1.	Introduction		1
2.	Presentation of Results		2
3.	Discussion of Results		3
4.	Conclusions and Recommendations		5
5.	Assessment Details		7
6.	Interim Statement of Cost		8
7.	Certificate - Marion A. Goudie		9
8.	Certificate - Phillip G. Hallof		10
9.	Appendix A		
10.	Appendix B		
<u>Part C:</u>	Illustrations	7 pieces	
	#1 Plan Map (in pocket)	Dwg. I. P. P. 4820	
	IP Data Plots	Dwg. IP 5845-1 to -6	

McPHAR GEOPHYSICS

NOTES ON THE THEORY, METHOD OF FIELD OPERATION, AND PRESENTATION OF DATA FOR THE INDUCED POLARIZATION METHOD

Induced Polarization as a geophysical measurement refers to the blocking action or polarization of metallic or electronic conductors in a medium of ionic solution conduction.

This electro-chemical phenomenon occurs wherever electrical current is passed through an area which contains metallic minerals such as base metal sulphides. Normally, when current is passed through the ground, as in resistivity measurements, all of the conduction takes place through ions present in the water content of the rock, or soil, i. e. by ionic conduction. This is because almost all minerals have a much higher specific resistivity than ground water. The group of minerals commonly described as "metallic", however, have specific resistivities much lower than ground waters. The induced polarization effect takes place at those interfaces where the mode of conduction changes from ionic in the solutions filling the interstices of the rock to electronic in the metallic minerals present

in the rock.

The blocking action or induced polarization mentioned above, which depends upon the chemical energies necessary to allow the ions to give up or receive electrons from the metallic surface, increases with the time that a d. c. current is allowed to flow through the rock; i. e. as ions pile up against the metallic interface the resistance to current flow increases. Eventually, there is enough polarization in the form of excess ions at the interfaces, to appreciably reduce the amount of current flow through the metallic particle. This polarization takes place at each of the infinite number of solution-metal interfaces in a mineralized rock.

When the d. c. voltage used to create this d. c. current flow is cut off, the Coulomb forces between the charged ions forming the polarization cause them to return to their normal position. This movement of charge creates a small current flow which can be measured on the surface of the ground as a decaying potential difference.

From an alternate viewpoint it can be seen that if the direction of the current through the system is reversed repeatedly before the polarization occurs, the effective resistivity of the system as a whole will change as the frequency of the switching is changed. This is a consequence of the fact that the amount of current flowing through each metallic interface depends upon the length of time that current has been passing through it in one direction.

The values of the per cent frequency effect or F. E. are a measurement of the polarization in the rock mass. However, since the measurement of the degree of polarization is related to the apparent resistivity of the rock mass it is found that the metal factor values or M. F. are the most useful values in determining the amount of polarization present in the rock mass. The MF values are obtained by normalizing the F. E. values for varying resistivities.

The induced polarization measurement is perhaps the most powerful geophysical method for the direct detection of metallic sulphide mineralization, even when this mineralization is of very low concentration. The lower limit of volume per cent sulphide necessary to produce a recognizable IP anomaly will vary with the geometry and geologic environment of the source, and the method of executing the survey. However, sulphide mineralization of less than one per cent by volume has been detected by the IP method under proper geological conditions.

The greatest application of the IP method has been in the search for disseminated metallic sulphides of less than 20% by volume. However, it has also been used successfully in the search for massive sulphides in situations where, due to source geometry, depth of source, or low resistivity of surface layer, the EM method can not be successfully applied. The ability to differentiate ionic conductors, such as water filled shear zones, makes the IP method a useful tool in checking EM

anomalies which are suspected of being due to these causes.

In normal field applications the IP method does not differentiate between the economically important metallic minerals such as chalcopyrite, chalcocite, molybdenite, galena, etc., and the other metallic minerals such as pyrite. The induced polarization effect is due to the total of all electronic conducting minerals in the rock mass. Other electronic conducting materials which can produce an IP response are magnetite, pyrolusite, graphite, and some forms of hematite.

In the field procedure, measurements on the surface are made in a way that allows the effects of lateral changes in the properties of the ground to be separated from the effects of vertical changes in the properties. Current is applied to the ground at two points in distance (X) apart. The potentials are measured at two other points (X) feet apart, in line with the current electrodes is an integer number (n) times the basic distance (X).

The measurements are made along a surveyed line, with a constant distance (nX) between the nearest current and potential electrodes. In most surveys, several traverses are made with various values of (n); i. e. (n) = 1, 2, 3, 4, etc. The kind of survey required (detailed or reconnaissance) decides the number of values of (n) used.

In plotting the results, the values of the apparent resistivity, apparent per cent frequency effect, and the apparent metal factor

measured for each set of electrode positions are plotted at the intersection of grid lines, one from the center point of the current electrodes and the other from the center point of the potential electrodes. (See Figure A.) The resistivity values are plotted above the line as a mirror image of the metal factor values below. On a second line, below the metal factor values, are plotted the values of the per cent frequency effect. In some cases the values of per cent frequency effect are plotted as superscripts of the metal factor value. In this second case the frequency effect values are not contoured. The lateral displacement of a given value is determined by the location along the survey line of the center point between the current and potential electrodes. The distance of the value from the line is determined by the distance (nX) between the current and potential electrodes when the measurement was made.

The separation between sender and receiver electrodes is only one factor which determines the depth to which the ground is being sampled in any particular measurement. The plots then, when contoured, are not section maps of the electrical properties of the ground under the survey line. The interpretation of the results from any given survey must be carried out using the combined experience gained from field results, model study results and theoretical investigations. The position of the electrodes when anomalous values are measured is important in the interpretation.

In the field procedure, the interval over which the potential differences are measured is the same as the interval over which the electrodes are moved after a series of potential readings has been made. One of the advantages of the induced polarization method is that the same equipment can be used for both detailed and reconnaissance surveys merely by changing the distance (X) over which the electrodes are moved each time. In the past, intervals have been used ranging from 25 feet to 2000 feet for (X). In each case, the decision as to the distance (X) and the values of (n) to be used is largely determined by the expected size of the mineral deposit being sought, the size of the expected anomaly and the speed with which it is desired to progress.

The diagram in Figure A demonstrates the method used in plotting the results. Each value of the apparent resistivity, apparent metal factor, and apparent per cent frequency effect is plotted and identified by the position of the four electrodes when the measurement was made. It can be seen that the values measured for the larger values of (n) are plotted farther from the line indicating that the thickness of the layer of the earth that is being tested is greater than for the smaller values of (n); i. e. the depth of the measurement is increased. When the F. E. values are plotted as superscripts to the MF values the third section of data values is not presented and the F. E. values are not contoured.

The actual data plots included with the report are prepared utilizing an IBM 360/75 Computer and a Calcomp 770/763 Incremental Plotting System. The data values are calculated, plotted, and contoured according to a programme developed by McPhar Geophysics. Certain symbols have been incorporated into the programme to explain various situations in recording the data in the field.

The IP measurement is basically obtained by measuring the difference in potential or voltage (ΔV) obtained at two operating frequencies. The voltage is the product of the current through the ground and the apparent resistivity of the ground. Therefore in field situations where the current is very low due to poor electrode contact, or the apparent resistivity is very low, or a combination of the two effects; the value of (ΔV) the change in potential will be too small to be measurable. The symbol "TL" on the data plots indicates this situation.

In some situations spurious noise, either man made or natural, will render it impossible to obtain a reading. The symbol "N" on the data plots indicates a station at which it is too noisy to record a reading. If a reading can be obtained, but for reasons of noise there is some doubt as to its accuracy, the reading is bracketed in the data plot ().

In certain situations negative values of Apparent Frequency Effect are recorded. This may be due to the geologic environment or spurious electrical effects. The actual negative frequency effect value recorded is indicated on the data plot, however the symbol "NEG" is

indicated for the corresponding value of Apparent Metal Factor. In contouring negative values the contour lines are indicated to the nearest positive value in the immediate vicinity of the negative value.

The symbol "NR" indicates that for some reason the operator did not attempt to record a reading although normal survey procedures would suggest that one was required. This may be due to inaccessible topography or other similar reasons. Any symbol other than those discussed above is unique to a particular situation and is described within the body of the report.

METHOD USED IN PLOTTING DIPOLE-DIPOLE INDUCED POLARIZATION AND RESISTIVITY RESULTS

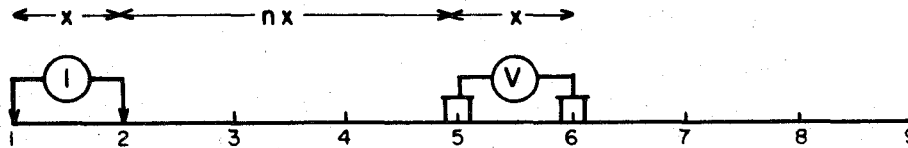

Stations on line

x = Electrode spread length
 n = Electrode separation

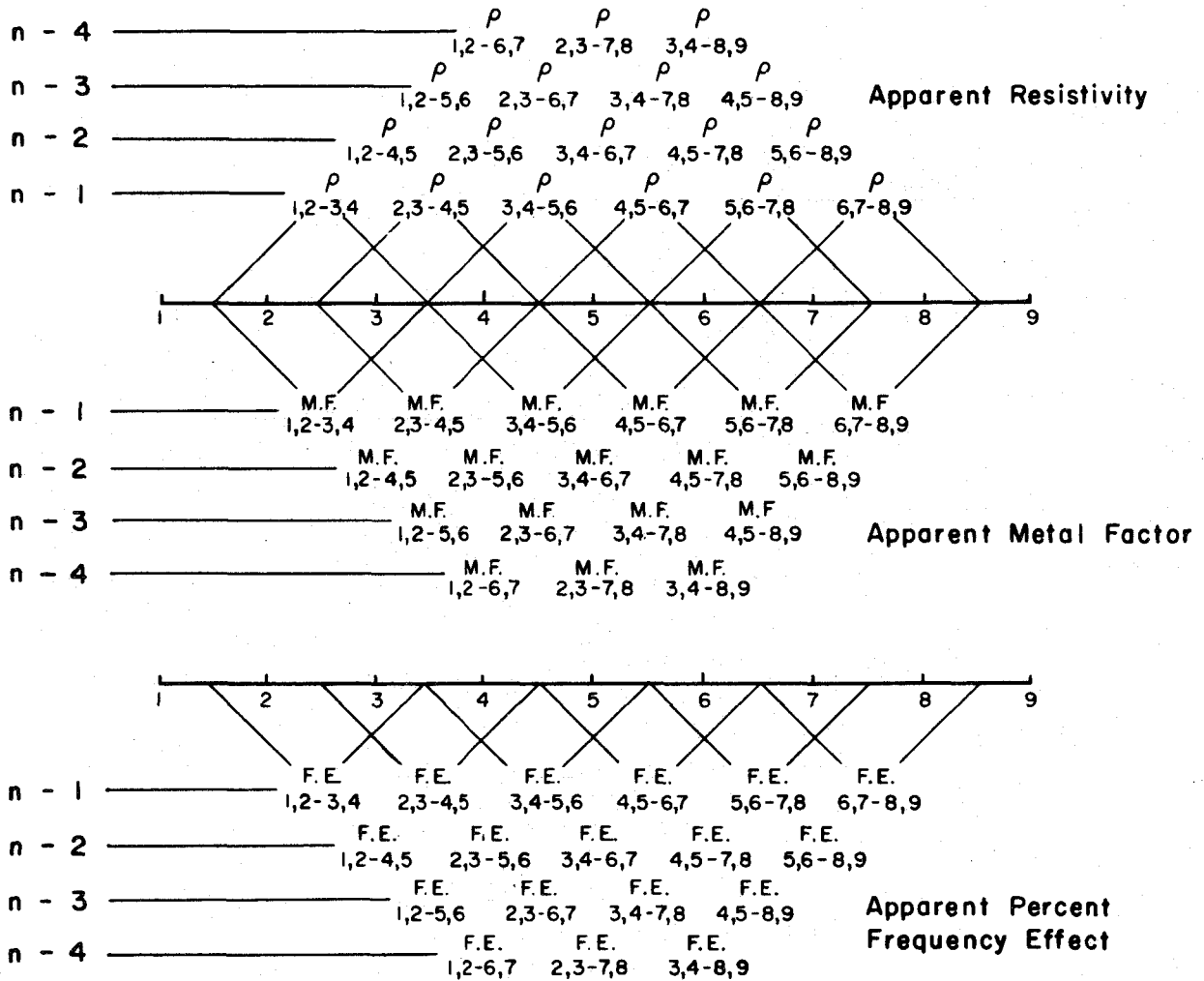

Fig. A

McPHAR GEOPHYSICS LIMITED

**REPORT ON THE
INDUCED POLARIZATION
AND RESISTIVITY SURVEY**

ON THE

KLI NO. 1 GROUP AND NO. 2 GROUP

KLIYUL CREEK AREA,

OMINECA MINING DIVISION, B.C.

FOR

KENNCO EXPLORATIONS (WESTERN) LIMITED

1. INTRODUCTION

At the request of Mr. R. W. Stevenson, Project Manager for the company, an Induced Polarization and Resistivity survey has been completed on the Kli No. 1 Group and Kli No. 2 Group of claims at the headwaters of Kliyul Creek, Omineca Mining Division, British Columbia. The survey grid is situated partly in the northeast quadrant and partly in the southeast quadrant of the 1° quadrilateral whose southeast corner is at 56°N latitude and 126°W longitude.

The country rocks are Takla volcanics with some limy sediments, cut by acid intrusives. Localized magnetite-skarn deposits are known to occur and there is some evidence of disseminated sulphide mineralization remote from the skarn deposit. The Induced Polarization and Resistivity survey was designed to explore the possibility of the disseminated sulphide mineralization being of economic interest.

The work was done in August, 1971, using a McPhar P660 high power

variable frequency IP unit, operating at 0.3 and 5 cps, over the following claims:

Kll 2, 4, 6, 8, 10, 11, 12, 13, 14, 15, 16, 17, 19, 22, 33, 35,
37, 39, 40, 41, 42, 44, 46, 47, 49.

These claims are assumed to be owned or held under option by Keneco Explorations (Western) Limited.

2. PRESENTATION OF RESULTS

The Induced Polarization and Resistivity results are shown on the following data plots in the manner described in the notes preceding this report.

<u>Line</u>	<u>Electrode Intervals</u>	<u>Dwg. No.</u>
800N	200 feet	IP 5845-1
0	200 feet	IP 5845-2
800S	200 feet	IP 5845-3
1600S	200 feet	IP 5845-4
2400S	200 feet	IP 5845-5
3200S	200 feet	IP 5845-6

Also enclosed with this report is Dwg. I.P.F. 4820, a plan map of the Kll Grid at a scale of 1" = 400'. The definite, probable and possible Induced Polarization anomalies are indicated by bars, in the manner shown on the legend, on this plan map as well as on the data plots. These bars represent the surface projection of the anomalous zones as interpreted from the location of the transmitter and receiver electrodes when the anomalous values were measured.

Since the Induced Polarisation measurement is essentially an averaging process, as are all potential methods, it is frequently difficult to exactly pinpoint the source of an anomaly. Certainly, no anomaly can be located with more accuracy than the electrode interval length; i. e. when using 200' electrode intervals the position of a narrow sulphide body can only be determined to lie between two stations 200' apart. In order to definitely locate, and fully evaluate, a narrow, shallow source it is necessary to use shorter electrode intervals. In order to locate sources at some depth, larger electrode intervals must be used, with a corresponding increase in the uncertainties of location. Therefore, while the centre of the indicated anomaly probably corresponds fairly well with source, the length of the indicated anomaly along the line should not be taken to represent the exact edges of the anomalous material.

The geological information has been made available by the staff of Keneco Explorations (Western) Limited.

3. DISCUSSION OF RESULTS

The survey results indicate the possibility of two types of mineralization, disseminated metallic mineralization and concentrated metallic mineralization, being present in the area which was explored. Two zones have been correlated and a third possible zone is indicated on Dwg. I. P. P. 4820.

Line 800N

A shallow, weak one-station anomaly extends from 14W to 16W. A narrow, weak anomaly, shallow but with some depth extent indicated, was located from 8W to 10W. A broad, weak anomaly extends from 6W to 4E; the source of this anomaly could be disseminated metallic mineralization.

Line 0

A weak anomaly from 58W to 63W, where it is incomplete, reflects a decrease in resistivities, but also decreased frequency effects, so that the anomaly is suspect. Two shallow, one-station anomalies were located from 44W to 46W and 32W to 34W. Detail with shorter electrode intervals might improve these anomalies.

A very broad, weak anomalous zone extends from 30W to 12E, with the magnitude of the anomaly varying throughout. This anomaly has been correlated with anomalies on Line 800N and Line 800S to form Zone 1. Adjoining this anomaly is a definite to possible anomaly from 12E to 23E. The top of the source lies at a depth of less than half the electrode interval (200') and the anomaly should be detailed with shorter electrode intervals to better define the source. This anomaly has been tentatively correlated with an anomaly on Line 800S to form Zone 3.

Line 800S

A probable to possible shallow anomaly was located from 46W to 53W. This is the northern anomaly in Zone 2. A broad, weak anomaly, varying in depth, extends from 36W to 15E and has been correlated into Zone 1. An incomplete probable anomaly from 15E to the east may correlate with a stronger anomaly on Line 0 and has been tentatively correlated as Zone 3. The line should be extended to the east to complete definition of the anomaly.

Line 1600S

The definite to probable anomaly from 36W to 50W, in Zone 2, may represent two sources, or alternatively, one source centred from 42W to 44W.

The top of the source is at a depth of less than half an electrode interval and the anomaly should be detailed with shorter electrode intervals to better define the source, or sources. A narrow, shallow anomaly from 28W to 30W might improve if detailed with shorter electrode intervals. This also applies to the weak, shallow anomaly from 16W to 20W.

Line 2400S

The definite to possible anomaly from 16W to 22W may represent more than one source, or alternatively, one deep source. From 22W to 30W is fairly typical of disseminated mineralization; the source is shallow, with some depth extent indicated. The anomaly from 16W to 22W has been correlated into Zone 2. Intermediate parallel lines between Line 800S to Line 3200S would be needed to confirm the Zone 2 correlation.

Line 3200S

The weak anomaly from 20W to 25W is shallow with some depth extent indicated. The anomaly, which has been correlated into Zone 2, should be detailed with shorter electrode intervals to better define the source.

4. CONCLUSIONS AND RECOMMENDATIONS

The anomalies which comprise Zone 1 are typical of disseminated metallic mineralization. The source of these anomalies lies at a depth of less than half an electrode interval and could be tested by drilling at any point within the anomalies.

Zone 2 should be confirmed and delimited by further IP work. The

correlation of the zone should be confirmed by parallel intermediate lines; the source of the zone on Line 16005 should be better defined by detail with shorter electrode intervals.

Zone 3 is a tentative correlation which could be checked by extending Line 8005 to the east and surveying one or more intermediate parallel lines between Line 0 and Line 8005. Should the correlation be confirmed, lines to the south of Line 8005 should be surveyed to delimit the source.

McPHAR GEOPHYSICS LIMITED

Marion A. Gaudie

Marion A. Gaudie,
Geophysicist

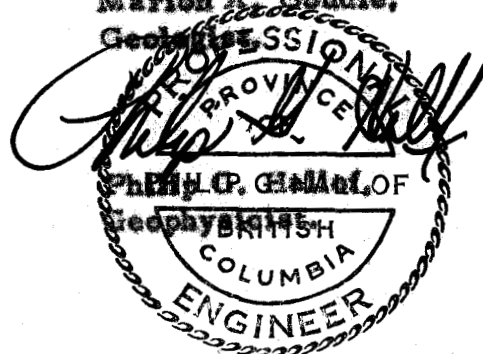

Dated: September 23, 1971

Expiry Date: February 23, 1972

ASSESSMENT DETAILS

PROPERTY: KII No. 1 and No. 2 Groups

MINING DIVISION: Omineca

SPONSOR: Kenneco Explorations (Western)
Limited

PROVINCE: British Columbia

LOCATION: Kiiyul Creek Area

TYPE OF SURVEY: Induced Polarization

OPERATING MAN DAYS: 36

DATE STARTED: August 14, 1971

EQUIVALENT 8 HR. MAN DAYS: 54

DATE FINISHED: August 28, 1971

CONSULTING MAN DAYS: 3

NUMBER OF STATIONS: 222

DRAUGHTING MAN DAYS: 4

NUMBER OF READINGS: 2304

TOTAL MAN DAYS: 61

MILES OF LINE SURVEYED: 8.1

CONSULTANTS:

Marion A. Goudie, 739 Military Trail, West Hill, Ontario.

Phillip G. Hallof, 11 Barnwood Court, Don Mills, Ontario.

FIELD TECHNICIANS:

D. Breswick, c/o McPhar Geophysics Ltd. Suite 811, 837 W. Hastings St.
Vancouver, B.C.

T. Heisterman, 1647 Hampshire, Victoria, B.C.

Plus 2 helpers supplied by client.

DRAUGHTSMEN:

K. Kingsbury, 58 Oak Avenue, Richvale, Ontario.

J. Preager, 20 Esterbrooke Avenue, Apt. 705, Willowdale, Ontario.

N. Lade, 299 Jasper Avenue, Oshawa, Ontario.

McPHAR GEOPHYSICS LIMITED

Marion A. Goudie

Marion A. Goudie,
Geologist.

Dated: September 23, 1971

INTERIM

STATEMENT OF COST

Kennco Explorations (Western) Limited - K11 No. 1 Group and No. 2 Group
Klilyal Creek Area, Omineca Mining Division, B.C. - IP Survey

Crew (2 men) D. Broswick
 T. Heisterman

9 days Operating		@ \$265.00/day	\$2,385.00
2½ days Preparation) 4½ days	@ \$100.00/day	450.00
2 days Bad Weather)		
1½ days Breakdown			N.C.
			<hr/> \$2,835.00 <hr/>

McPHAR GEOPHYSICS LIMITED

Marion A. Goudie

Marion A. Goudie,
Geologist.

Dated: September 23, 1971

CERTIFICATE

I, Marion A. Goudie, of the City of Toronto, Province of Ontario,
do hereby certify that:-

1. I am a geologist residing at 739 Military Trail, West Hill, Ontario.
2. I am a graduate of the University of Western Ontario with a B.Sc. Degree (1950) in Honours Geology.
3. I am a member of the Geological Society of America.
4. I have been practising my profession for 20 years.
5. I have no direct or indirect interest, nor do I expect to receive any interest directly or indirectly, in the property or securities of Kenneco Explorations (Western) Limited or any affiliate.
6. The statements made in this report are based on a study of published geological literature and unpublished private reports.
7. Permission is granted to use in whole or in part for assessment and qualification requirements but not for advertising purposes.

Dated at Toronto

This 23rd Day of September 1971.



Marion A. Goudie, B.Sc.

CERTIFICATE

I, Philip George Hallot, of the City of Toronto, Province of Ontario,
do hereby certify that:-

1. I am a geophysicist residing at 11 Barnwood Court, Don Mills, Ontario.
2. I am a graduate of the Massachusetts Institute of Technology with a B.Sc. Degree (1952) in Geology and Geophysics and a Ph.D. Degree (1957) in Geophysics.
3. I am a member of the Society of Exploration Geophysicists and the European Association of the Exploration Geophysicists.
4. I am a Professional Geophysicist, registered in the Province of Ontario, the Province of British Columbia and the State of Arizona.
5. I have no direct or indirect interest, nor do I expect to receive any interest directly or indirectly, in the property or securities of Keanco Explorations (Western) Limited or any affiliate.
6. The statements made in this report are based on a study of published geological literature and unpublished private reports.
7. Permission is granted to use in whole or in part for assessment and qualification requirements but not for advertising purposes.

Dated at Toronto

This 23rd Day of September 1971.

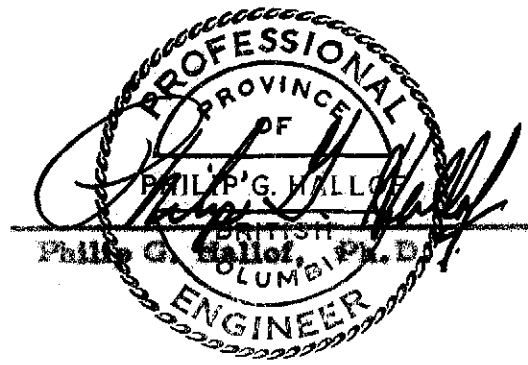

Expiry Date: February 25, 1972

McPHAR GEOPHYSICS

APPENDIX A

EXPECTED IP ANOMALIES FROM "PORPHYRY COPPER" TYPE ZONES OF DISSEMINATED SULPHIDE MINERALIZATION

Our experience in other areas has shown that the induced polarization method can be successfully used to locate, and outline, zones of disseminated sulphide mineralization of the "porphyry copper" type. In most cases the interpretation of the IP results is simple and straightforward. The results shown in Figure 1 and Figure 2 are typical.

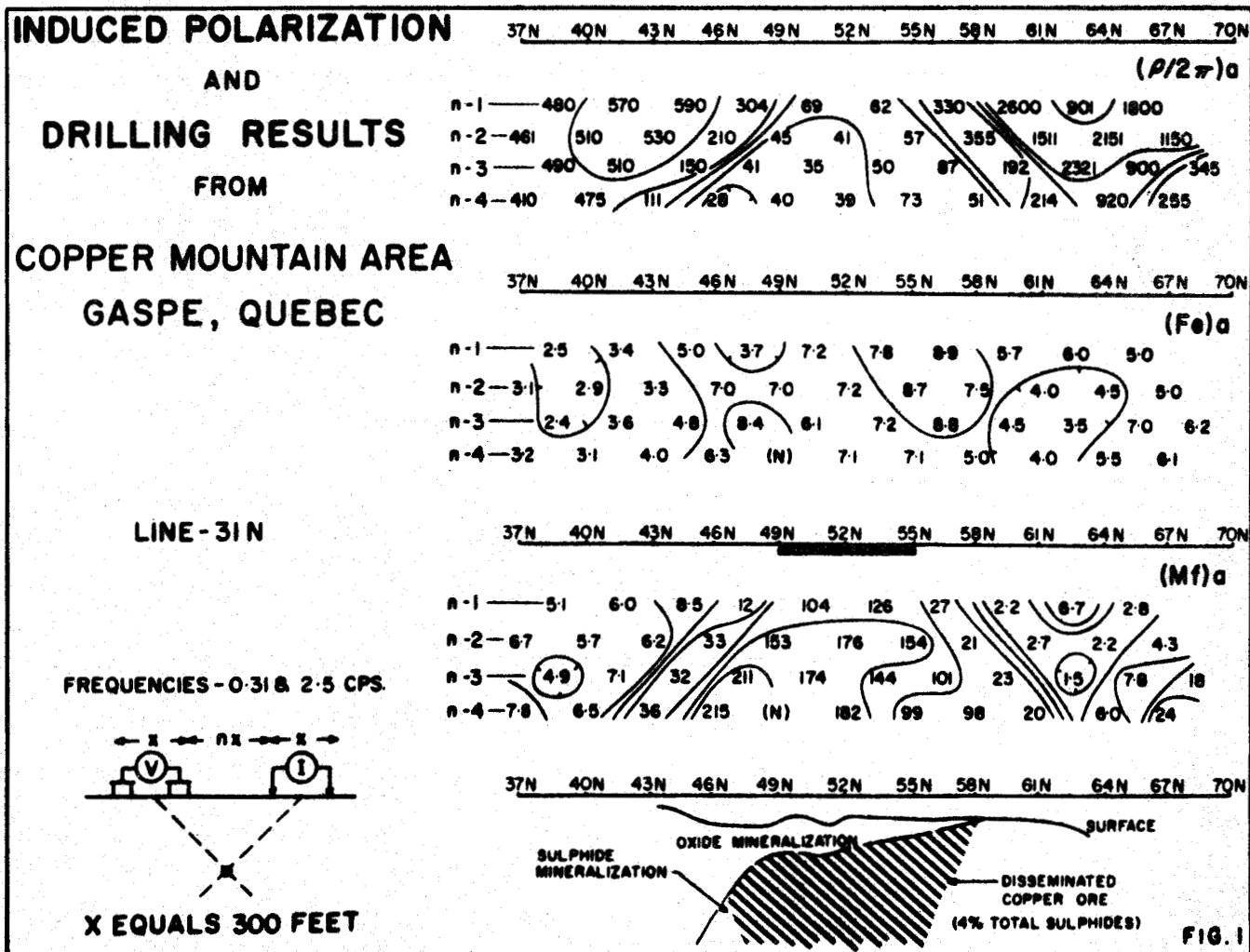

The source of the moderate magnitude IP anomaly shown in Figure 1 contains approximately 4% metallic mineralization. The zone is of limited lateral extent and enough copper is present to make the mineralization "ore grade". The presence of the surface oxidation can be seen in the fact that the apparent IP effects increase for $n = 2$.

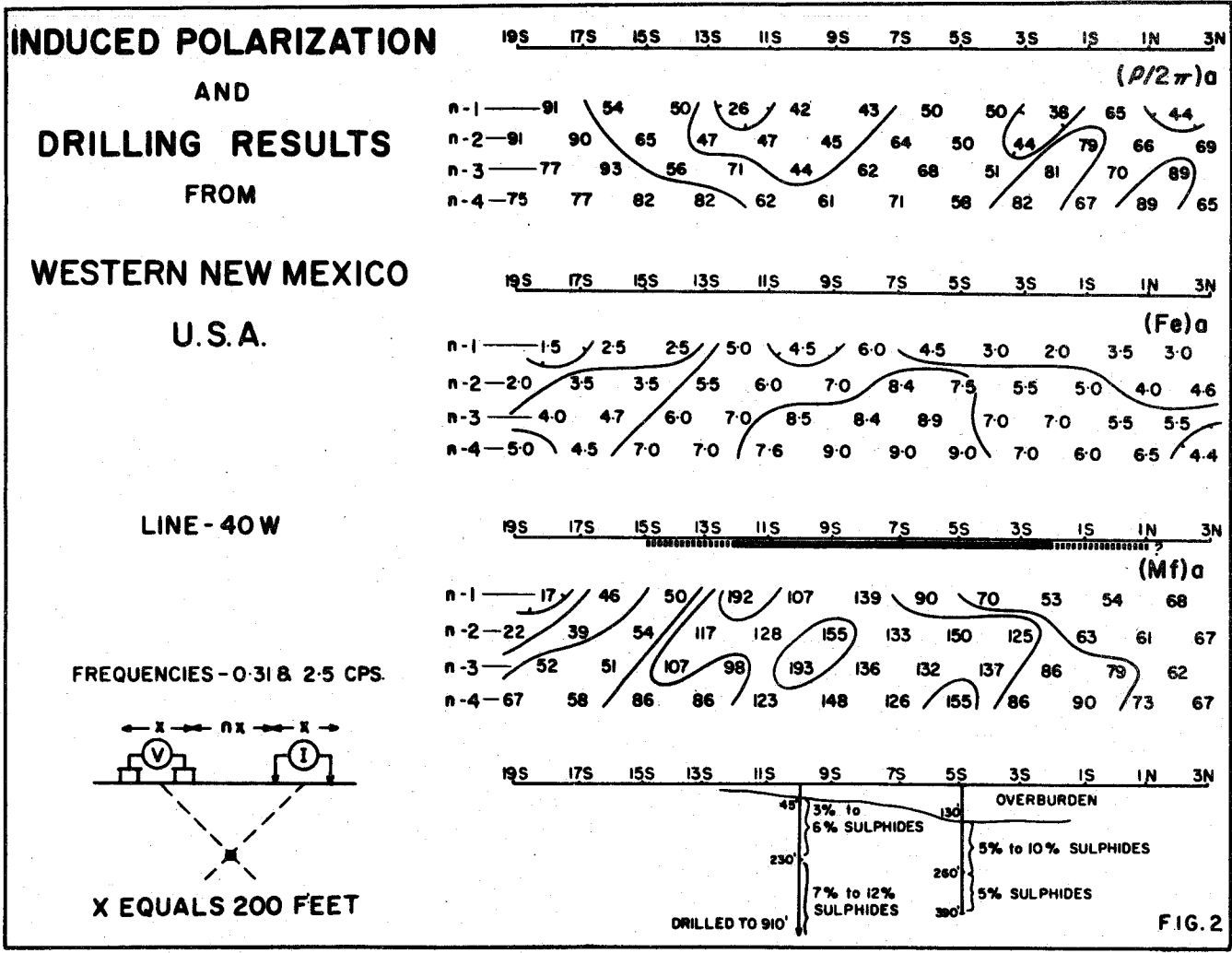

The IP anomaly shown in Figure 2 has about the same magnitude as that described above. It should be noted that appreciably greater concentrations of metallic mineralization are present; further, there is little or no copper present. These results illustrate the fact that IP results can not be used to determine the exact amount of metallic mineralization present or to determine the economic importance of a mineralized zone. In some geologic situations zoning is present; the zones of mineralization of greatest economic value may contain less total metallic mineralization than other zones in the same general area.

In the proper geologic environment, the method will detect even very low concentrations of metallic mineralization. The IP results shown in Figure 3 located the ore zone at the Brenda Property near Peachland, B. C. The zone contains 1.0 to 1.5 per cent metallic mineralization; however, the mineralization is "ore grade" because only molybdenite and chalcocopyrite are present.

INDUCED POLARIZATION

**AND
DRILLING RESULTS**

**FROM
BRENDA AREA
PEACHLAND, B.C.**

24W 20W 16W 12W 8W 4W 0 4E 8E 12E 16E 20E

($\rho/2\pi$)a

n-1	267	222	242	287	245	396	850	238
n-2	420	200	228	272	310	346	387	334
n-3	320	100	242	302	356	290	236	247
n-4	322	297	192	270	322	368	245	196

24W 20W 16W 12W 8W 4W 0 4E 8E 12E 16E 20E

(Fe)a

n-1	0.9	1.5	4.0	4.3	3.5	3.0	2.6	1.4
n-2	0.5	0.6	5.0	3.5	3.0	3.0	2.0	1.2
n-3	0.3	3.7	2.5	3.2	3.0	3.0	1.8	1.0
n-4	0.3	1.7	3.1	3.0	5.0	1.0	(N)	1.5

LINE - 8S

24W 20W 16W 12W 8W 4W 0 4E 8E 12E 16E 20E

(Mf)a

n-1	3.3	6.7	1.7	1.5	1.4	7.5	2.9	5.8
n-2	0.7	3.0	2.2	1.3	9.8	8.7	6.3	3.6
n-3	0.9	3.6	1.0	1.0	8.4	1.0	7.6	4.0
n-4	0.9	5.7	1.6	1.1	1.5	2.7	(N)	7.9

FREQUENCIES - 0.31 & 5.0 CPS.

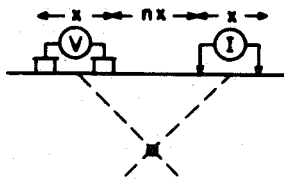

X EQUALS 400 FEET

24W 20W 16W 12W 8W 4W 0 4E 8E 12E 16E 20E



FIG. 3

McPHAR GEOPHYSICS

APPENDIX B

THE INTERPRETATION OF INDUCED POLARIZATION ANOMALIES FROM RELATIVELY SMALL SOURCES

The induced polarization method was originally developed to detect disseminated sulphides and has proven to be very successful in the search for "porphyry copper" deposits. In recent years we have found that the IP method can also be very useful in exploring for more concentrated deposits of limited size. This type of source gives sharp IP anomalies that are often difficult to interpret.

The anomalous patterns that develop on the contoured data plots will depend on the size, depth and position of the source and the relative size of the electrode interval. The data plots are not sections showing the electrical parameters of the ground. When the electrode interval (X) is appreciably greater than the width of the source, a large volume of unmineralized rock is averaged into each measurement. This is particularly true for the large values of the electrode separation (n).

The theoretical scale model results shown in Figure 1 and Figure 2 indicate the effect of depth. If the depth to the top of the source is small compared to the electrode interval (i. e. $d \ll X$) the measurement for $n = 1$ will be anomalous. In Figure 1 the depth is 0.5 units ($X = 1.0$ units) and the $n = 1$ value is definitely anomalous; the pattern on the contoured data plot is typical for a relatively shallow, narrow, near-vertical tabular source. The results in Figure 2 are for the same source with the depth increased to 1.5 units. Here the $n = 1$ value is not anomalous; the larger values of (n) are anomalous but the magnitudes are much lower than for the source at less depth.

When the electrode interval is greater than the width of the source, it is not possible to determine its width or exact position between the electrodes. The true IP effect within the source is also indeterminate; the anomaly from a very narrow source with a very large true IP effect will be much the same as that from a zone with twice the width and $1/2$ the true IP effect. The theoretical scale model data shown in Figure 3 and Figure 4 demonstrate this problem. The depth and position of the source are unchanged but the width and true IP effect are varied. The anomalous patterns and magnitudes are essentially the same, hence the data are insufficient to evaluate the source completely.

The normal practise is to indicate the IP anomalies by solid, broken, or dashed bars, depending upon their degree of distinctiveness. These bars represent the surface projection of the anomalous zones as interpreted from the location of the transmitter and receiver electrodes

when the anomalous values were measured. As illustrated in Figure 1, Figure 2, Figure 3 and Figure 4, no anomaly can be located with more accuracy than the spread length. While the centre of the solid bar indicating the anomaly corresponds fairly well with the source, the length of the bar should not be taken to represent the exact edges of the anomalous material.

If the source is shallow, the anomaly can be better evaluated using a shorter electrode interval. When the electrode interval used approaches the width of the source, the apparent effects measured will be nearly equal to the true effects within the source. When there is some depth to the top of the source, it is not possible to use electrode intervals that are much less than the depth to the source. In this situation, one must realize that a definite ambiguity exists regarding the width of the source and the IP effect within the source.

Our experience has confirmed the desirability of doing detail. When a reconnaissance IP survey using a relatively large electrode interval indicates the presence of a narrow, shallow source, detail with shorter electrode intervals is necessary in order to better locate, and evaluate, the source. The data of most usefulness is obtained when the maximum apparent IP effect is measured for $n = 2$ or $n = 3$. For instance, an anomaly originally located using $X = 300'$ may be checked with $X = 200'$ and then $X = 100'$. The data with $X = 100'$ will be quite different from the original reconnaissance results with $X = 300'$.

The data shown in Figure 5 and Figure 6 are field results from a greenstone area in Quebec. The expected sources were narrow (less than 30' in width) zones of massive, high-grade, zinc-silver ore. An electrode interval of 200' was used for the reconnaissance survey in order to keep the rate of progress at an acceptable level. The anomalies located were low in magnitude.

The very weak, shallow anomaly shown in Figure 5 is typical of those located by the $X = 200'$ reconnaissance survey. Several anomalies of this type were detailed using shorter electrode intervals. In most cases the detail measurements suggested broad zones of very weak mineralization. However, in the case of the source at 20N to 22N, the measurements with shorter electrode intervals confirmed the presence of a strong, narrow source. The $X = 50'$ results are shown in Figure 6. Subsequent drilling has shown the source to be 12.5' of massive sulphide mineralization containing significant zinc and silver values.

The change in the anomaly that results when the electrode interval is reduced is not unusual. The $X = 50'$ data more accurately locates the narrow source, and permits the geophysicist to make a better evaluation of its importance. The completion of this type of detail is very important, in order to get the maximum usefulness from a reconnaissance IP survey.

McPHAR GEOPHYSICS LIMITED
Theoretical Induced Polarization and Resistivity Studies
Scale Model Cases

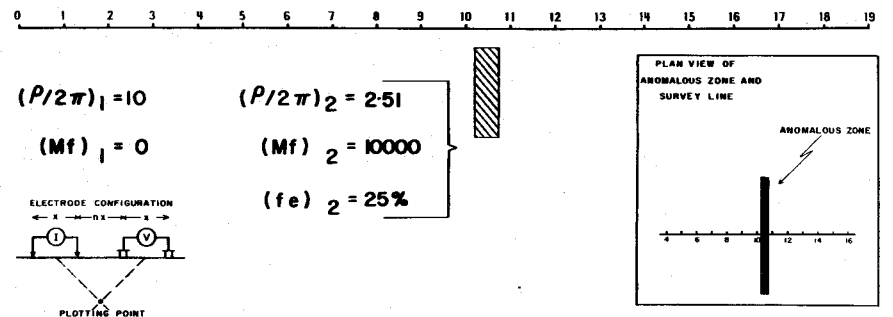
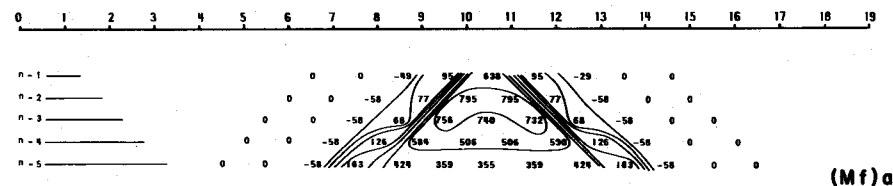
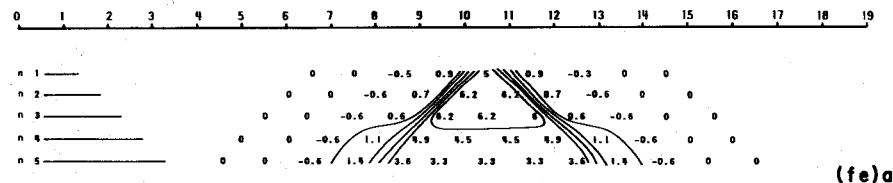
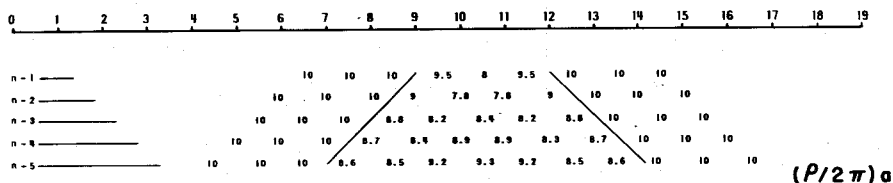

McPHAR GEOPHYSICS LIMITED
Theoretical Induced Polarization and Resistivity Studies
Scale Model Cases

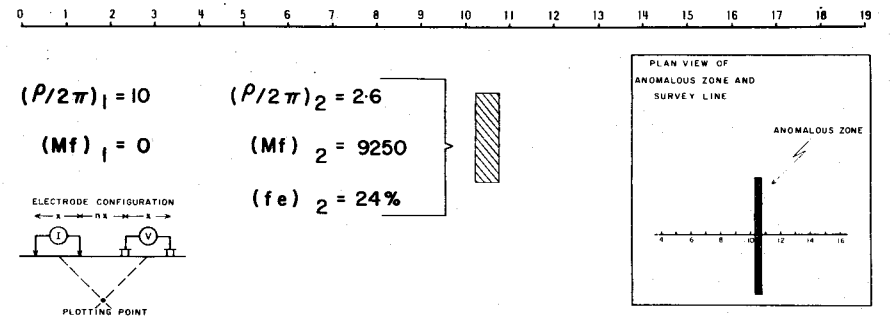
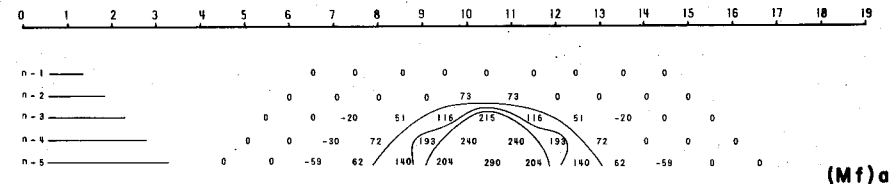
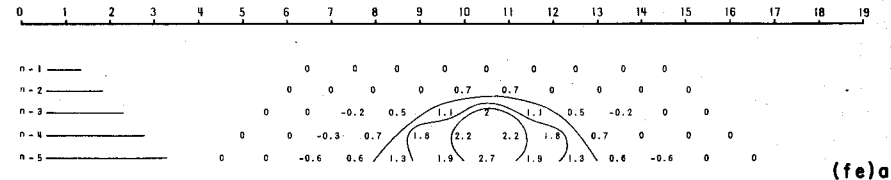
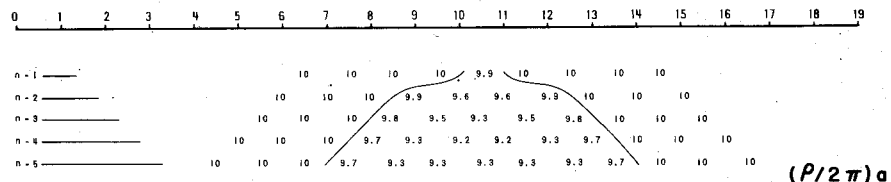

THEORETICAL INDUCED POLARIZATION AND RESISTIVITY STUDIES

SCALE MODEL CASE

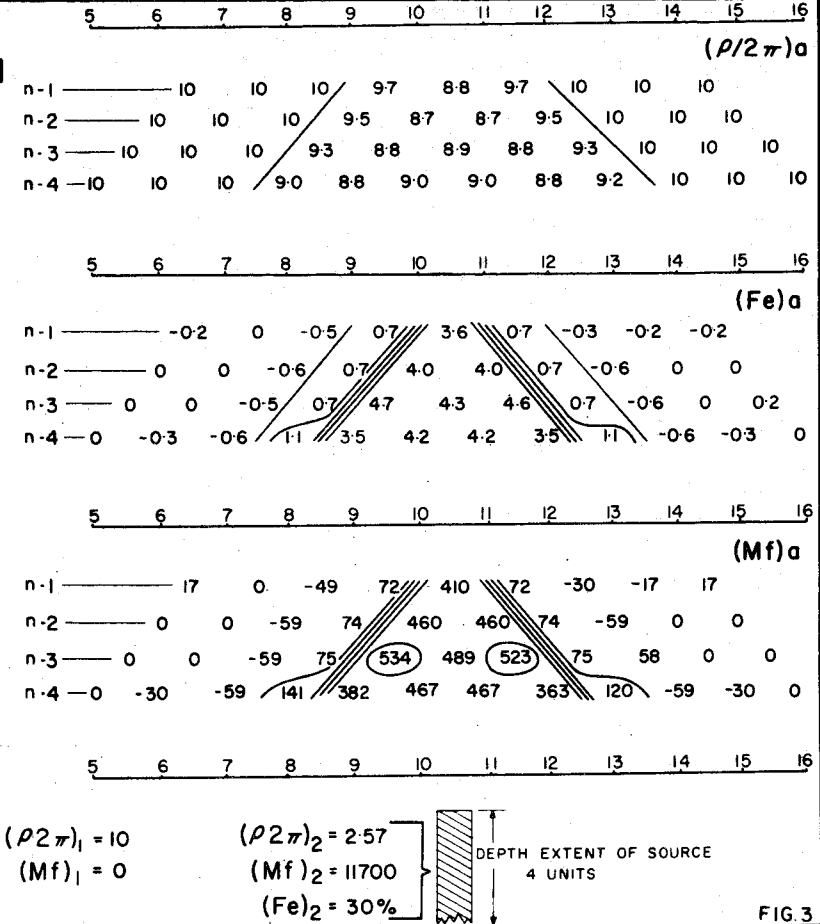
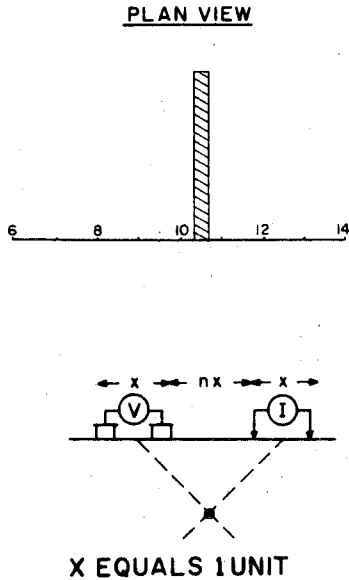

THEORETICAL INDUCED POLARIZATION AND RESISTIVITY STUDIES

SCALE MODEL CASE

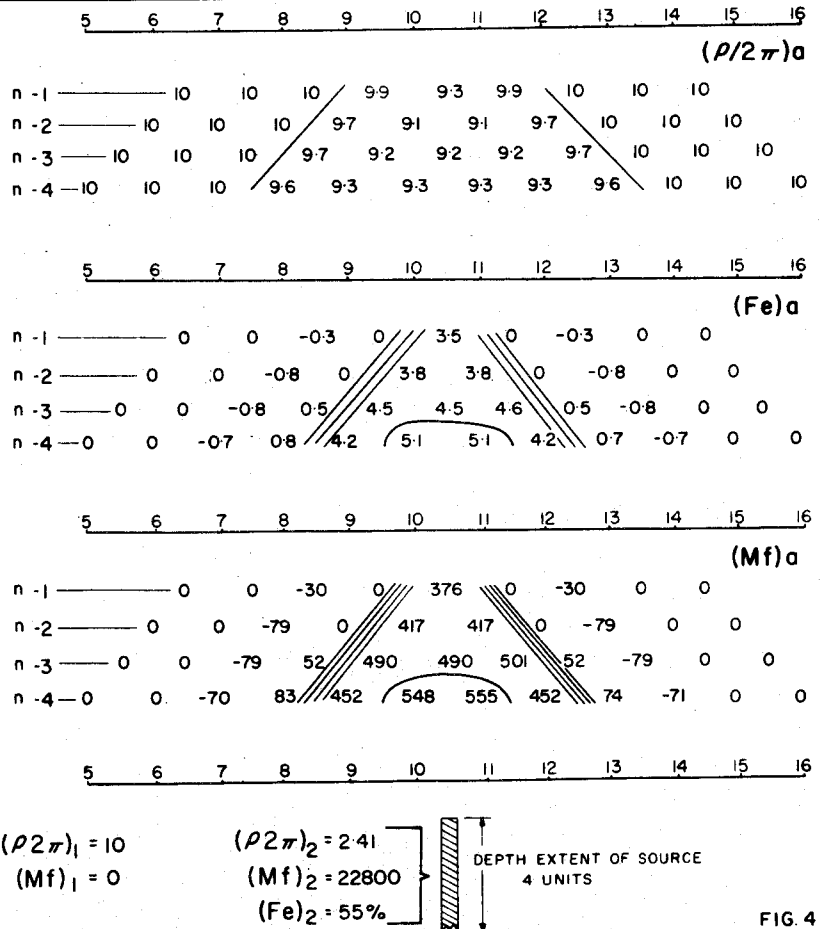
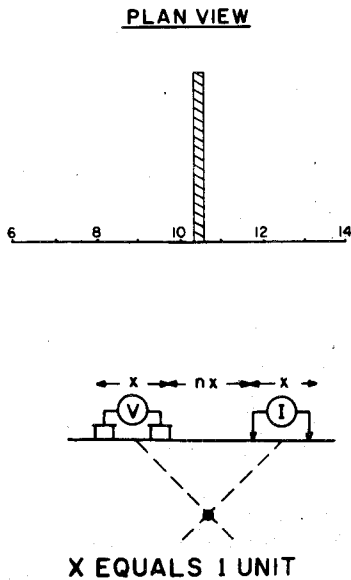

INDUCED POLARIZATION AND RESISTIVITY RESULTS
 BATCHELOR LAKE AREA, QUEBEC.

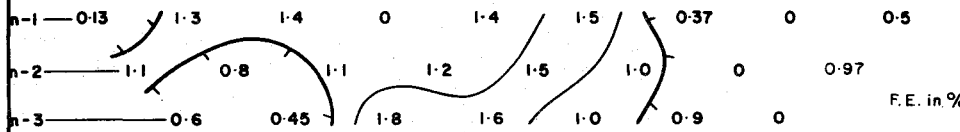
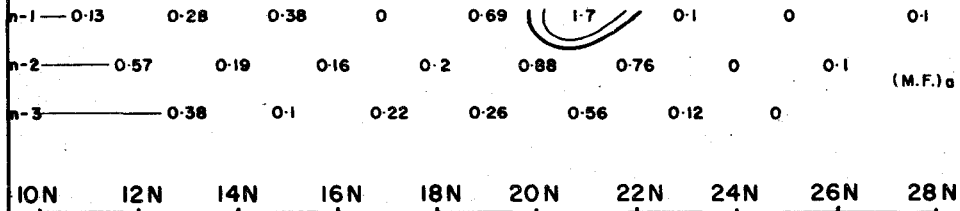
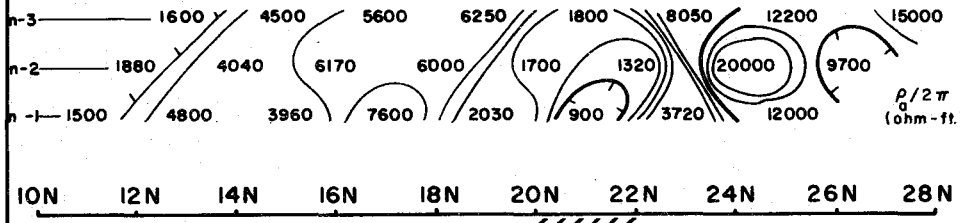

MASSIVE SULPHIDE
 ZONE

FIG. 5

INDUCED POLARIZATION AND RESISTIVITY RESULTS
 BATCHELOR LAKE AREA, QUEBEC.

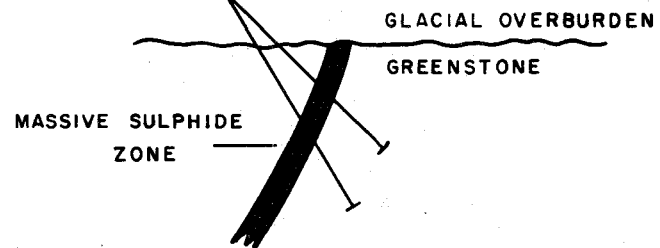
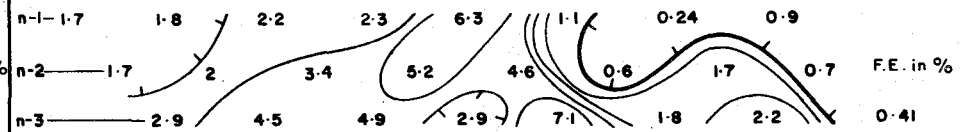
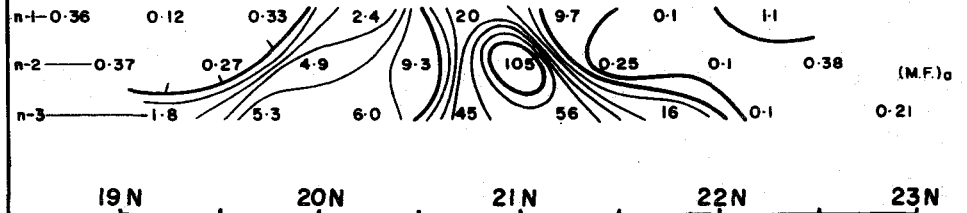
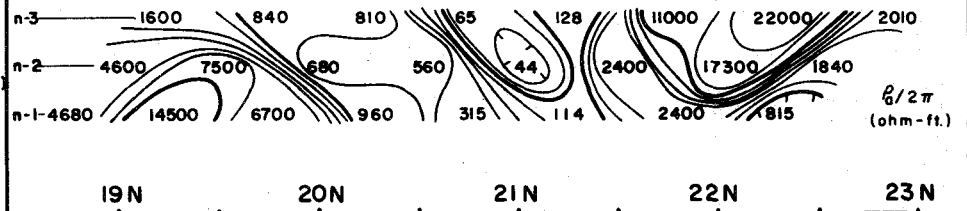

FIG. 6



3313 DWG. NO. - I.P. - 5845-1

**KENNECO EXPLORATIONS
(WESTERN) LTD.**

KLI NO. 1 & 2 GROUPS, KLIYUL CREEK AREA
OMINECA M.D., B.C.

LINE NO. - 800N

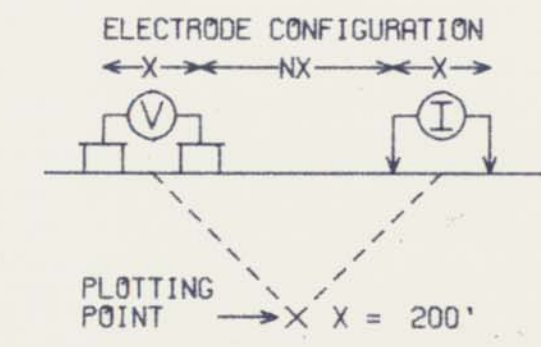

SURFACE PROJECTION
OF ANOMALOUS ZONES
 DEFINITE —————
 PROBABLE ■■■■■■■■■■■
 POSSIBLE / / / / /

FREQUENCIES: 0.31-5.0 HZ DATE SURVEYED: AUG 1971

APPROVED: *[Signature]*
 DATE: 25/10/71
 PHILIP G. HALLOF
 BRITISH COLUMBIA
 ENGINEER
 Expiry Date: February 25, 1972

NOTE: CONTOURS AT
LOGARITHMIC INTERVALS
1.-1.5-2.-3.-5.-7.5-10

McPHAR GEOPHYSICS

INDUCED POLARIZATION AND RESISTIVITY SURVEY

NOTE: THIS PLOT WAS PRODUCED WITH AN IBM 360/65 COMPUTER AND A CALCOMP PLOTTER

KENNCO EXPLORATIONS (WESTERN) LTD.

KLI NO. 1 & 2 GROUPS, KLIYUL CREEK AREA
OMINECA M.D., B.C.

LINE NO. - 0

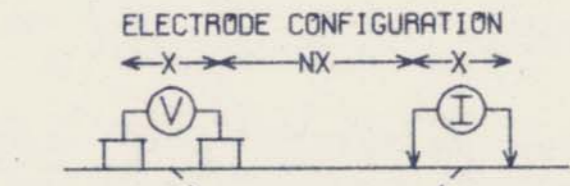

PLOTTING POINT X = 200'

SURFACE PROJECTION OF ANOMALOUS ZONES
DEFINITE
PROBABLE
POSSIBLE

FREQUENCIES: 0.31-5.0 HZ DATE SURVEYED: AUG 1971

APPROVED:

DATE: 23 JUL 1971

BRITISH COLUMBIA ENGINEER

Expiry Date: February 25, 1972

McPHAR GEOPHYSICS

INDUCED POLARIZATION AND RESISTIVITY SURVEY

NOTE: THIS PLOT WAS PRODUCED WITH AN IBM 360/65 COMPUTER AND A CALCOMP PLOTTER

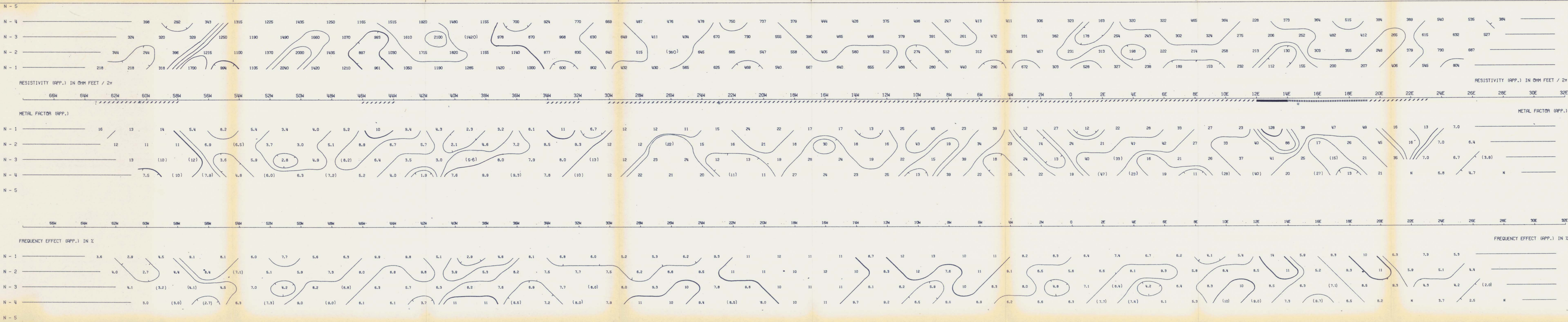

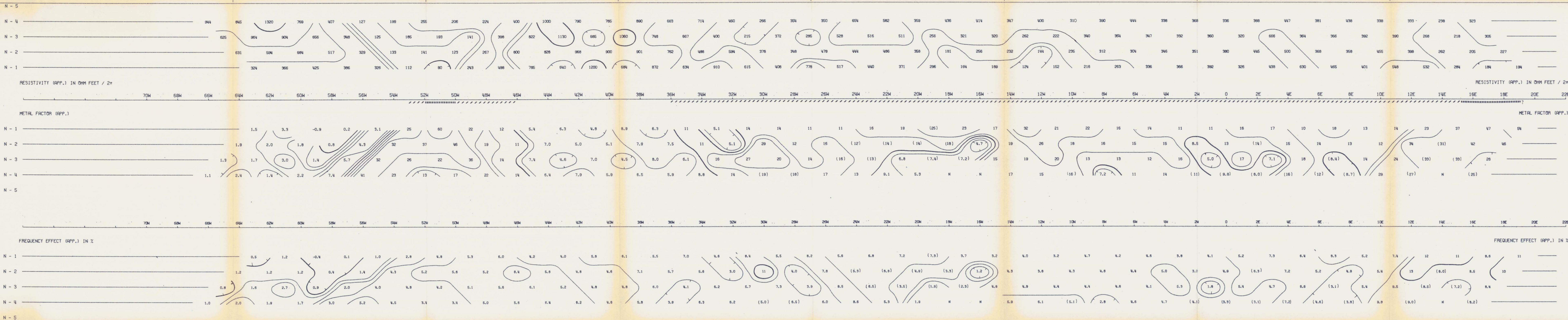

DWG. NO. - I.P. - 5845-3

**KENCO EXPLORATIONS
(WESTERN) LTD.**

KLI NO. 1 & 2 GROUPS, KLIYUL CREEK AREA
OMINECA M.D., B.C.

LINE NO. - 8005

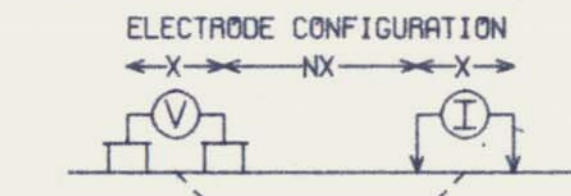

PLOTTING POINT X = 200'

SURFACE PROJECTION OF ANOMALOUS ZONES
DEFINITE
PROBABLE
POSSIBLE

FREQUENCIES: 0.31-5.0 HZ

DATE SURVEYED: AUG 1971

APPROVED:

DATE: 23 AUG 1971



NOTE: CONTOURS AT LOGARITHMIC INTERVALS 1.-1.5-2.-3.-5.-7.5-10

McPHAR GEOPHYSICS

INDUCED POLARIZATION AND RESISTIVITY SURVEY

NOTE: THIS PLOT WAS PRODUCED WITH AN IBM 360/65 COMPUTER AND A CALCOMP PLOTTER

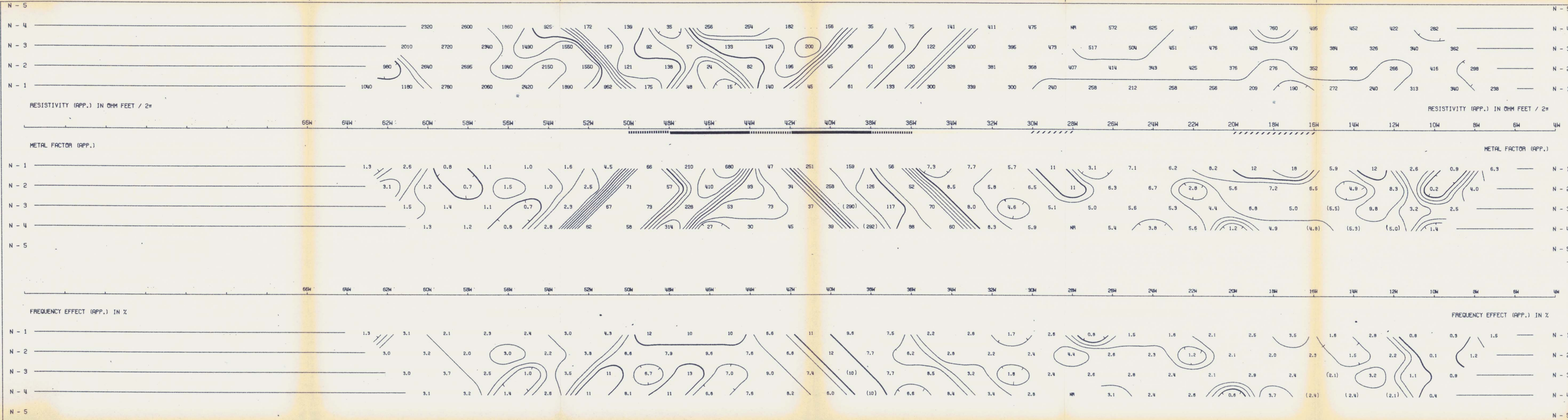

DWG. NO. - I.P. - 5845-4

**KENNECO EXPLORATIONS
(WESTERN) LTD.**

KLI NO. 1 & 2 GROUPS, KLIYUL CREEK AREA
OMINECA M.D., B.C.

LINE NO. - 1600S

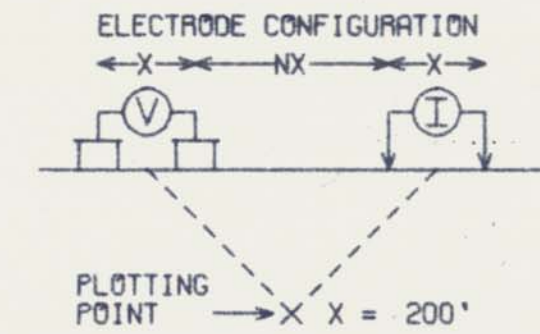

SURFACE PROJECTION
OF ANOMALOUS ZONES
 DEFINITE —————
 PROBABLE —————
 POSSIBLE / / / / /

FREQUENCIES: 0.31-5.0 HZ DATE SURVEYED: AUG 1971

APPROVED: *[Signature]*
 DATE: 23 Sept 71
 PROFESSIONAL ENGINEER
 PHILIP J. HALLOF
 COLUMBIA
 Expiry Date: February 25, 1972

NOTE: CONTOURS AT
LOGARITHMIC INTERVALS
1.-1.5-2.-3.-5.-7.5-10

McPHAR GEOPHYSICS

INDUCED POLARIZATION AND RESISTIVITY SURVEY

NOTE: THIS PLOT WAS PRODUCED WITH AN IBM 360/65 COMPUTER AND A CALCOMP PLOTTER



DWG. NO. - I.P. - 5845-5

**KENNCO EXPLORATIONS
(WESTERN) LTD.**

KLI NO. 1 & 2 GROUPS, KLIYUL CREEK AREA
OMINECA M.D., B.C.

LINE NO. - 24005

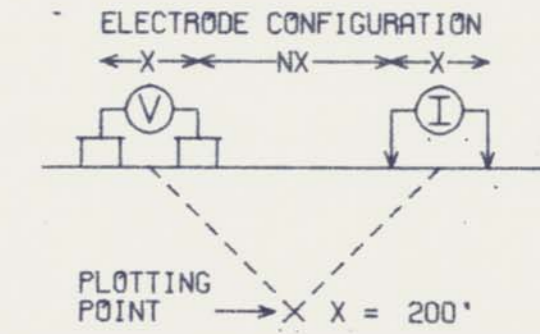

**SURFACE PROJECTION
OF ANOMALOUS ZONES**
 DEFINITE
 PROBABLE
 POSSIBLE

FREQUENCIES: 0.31-5.0 HZ DATE SURVEYED: AUG 1971

APPROVED: *Philip L. Salter*
 DATE: 23 Sept 71
 PROFESSIONAL ENGINEER
 BRITISH COLUMBIA
 Expiry Date: February 25, 1972

NOTE: CONTOURS AT LOGARITHMIC INTERVALS 1.-1.5-2.-3.-5.-7.5-10

McPHAR GEOPHYSICS

INDUCED POLARIZATION AND RESISTIVITY SURVEY

NOTE: THIS PLOT WAS PRODUCED WITH AN IBM 360/65 COMPUTER AND A CALCOMP PLOTTER

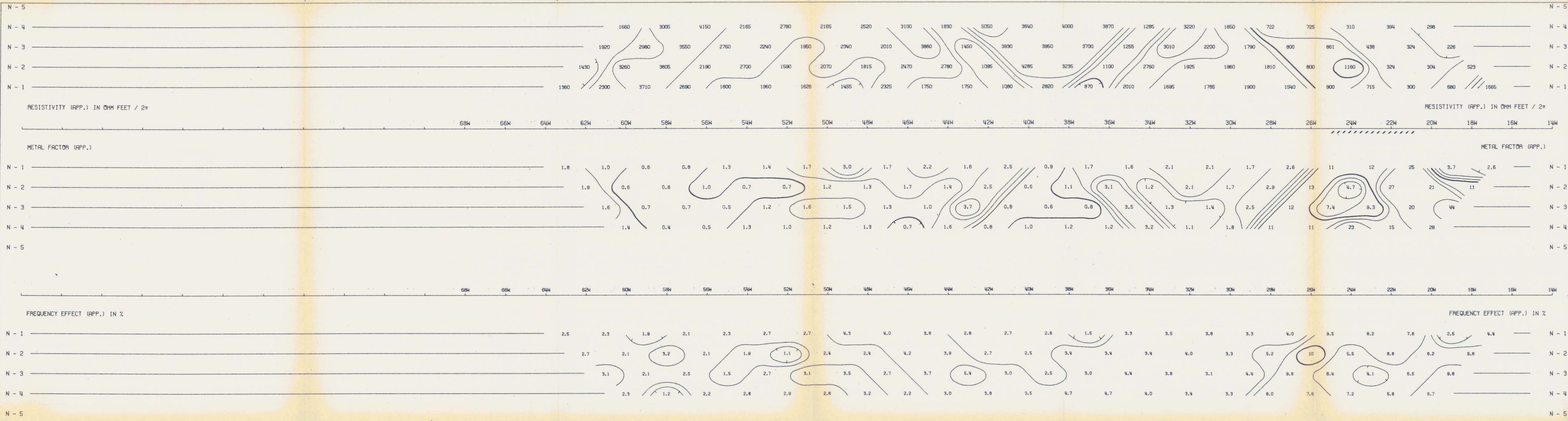

DWG. NO. - I.P. - 5845-6

**KENNECO EXPLORATIONS
(WESTERN) LTD.**

KLI NO. 1 & 2 GROUPS, KLIYUL CREEK AREA
OMINECA M.D., B.C.

LINE NO. - 3200S

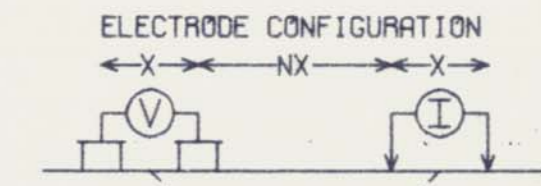

PLOTTING POINT X X = 200'

SURFACE PROJECTION OF ANOMALOUS ZONES

DEFINITE
 PROBABLE
 POSSIBLE

FREQUENCIES: 0.31-5.0 HZ

DATE SURVEYED: AUG 1971

APPROVED:
 BRITISH ENGINEER
 DATE: 23 Sept 71
 Expiry Date: February 22, 1972

NOTE: CONTOURS AT LOGARITHMIC INTERVALS 1.-1.5-2.-3.-5.-7.5-10

McPHAR GEOPHYSICS

INDUCED POLARIZATION AND RESISTIVITY SURVEY

NOTE: THIS PLOT WAS PRODUCED WITH AN IBM 360/65 COMPUTER AND A CALCOMP PLOTTER

McPHAR GEOPHYSICS
 INDUCED POLARIZATION AND RESISTIVITY SURVEY
 PLAN MAP

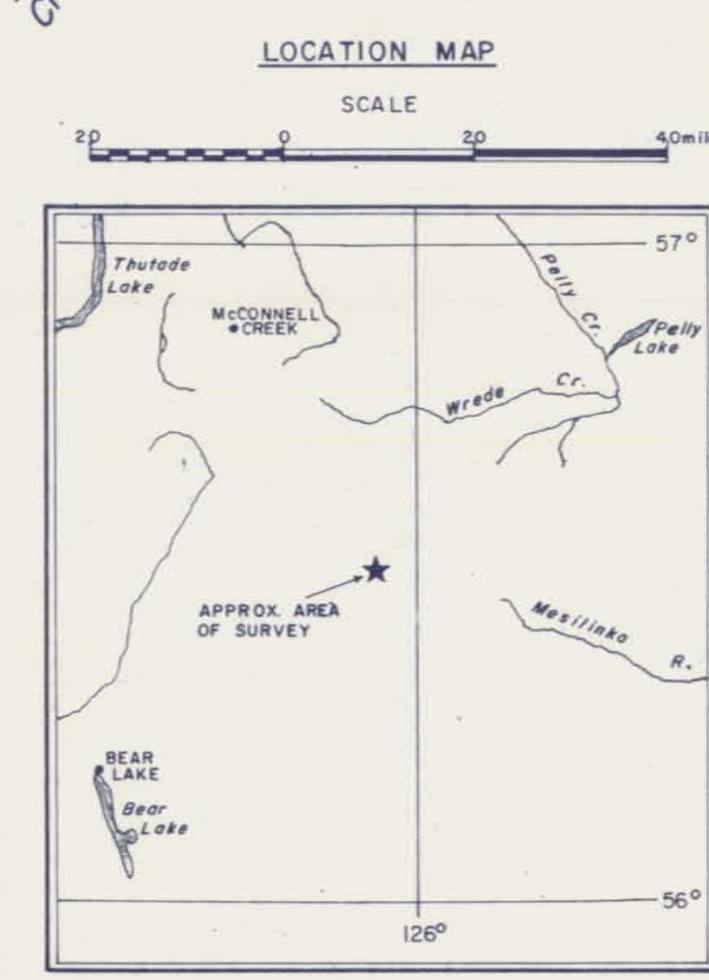
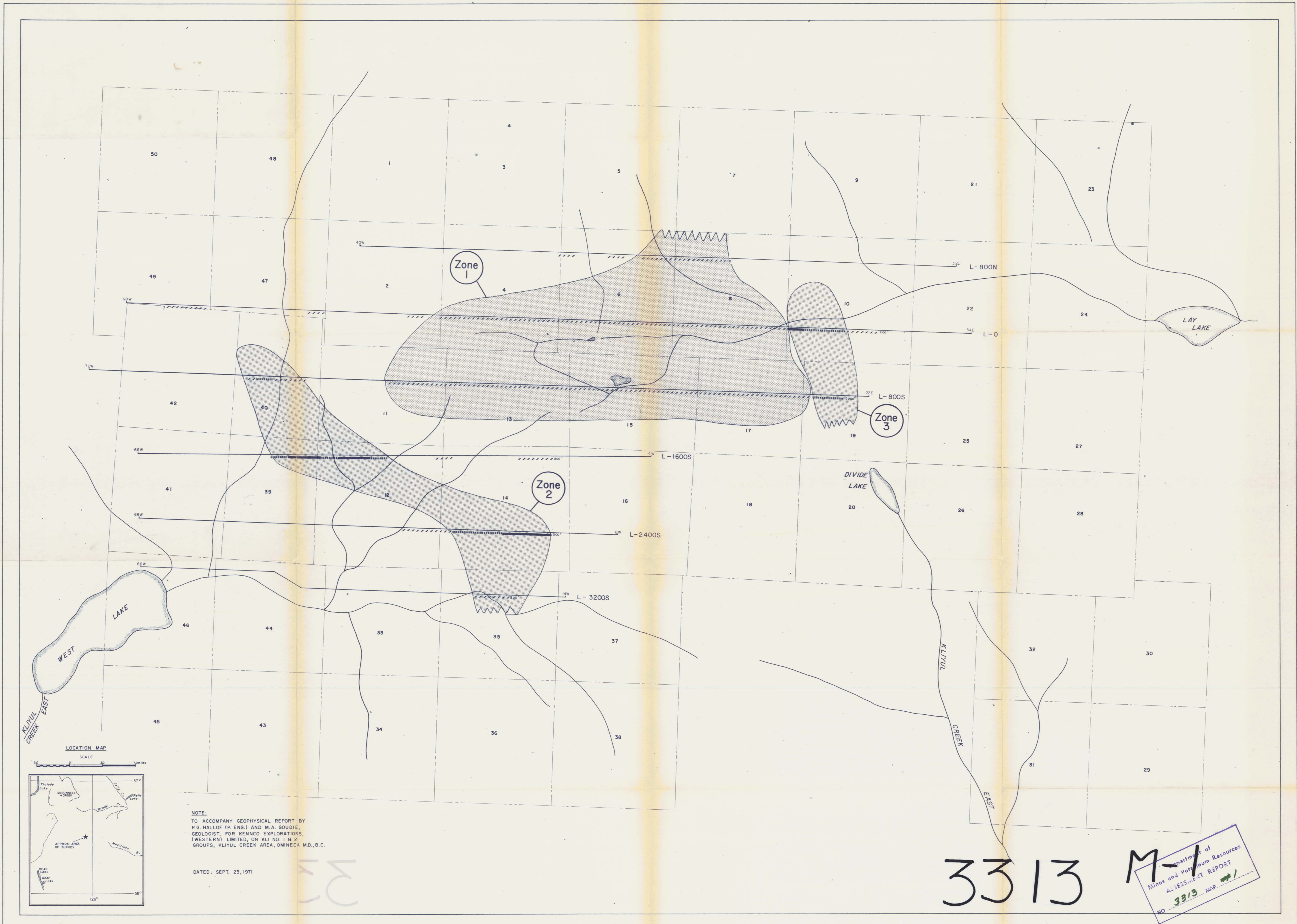

NOTE:
 TO ACCOMPANY GEOPHYSICAL REPORT BY
 P.G. HALLOF (P. ENG.) AND M.A. GOUDIE,
 GEOLOGIST, FOR KENCO EXPLORATIONS,
 (WESTERN) LIMITED, ON KLI NO. 1 & 2
 GROUPS, KLIYUL CREEK AREA, OMINECA M.D., B.C.

DATED: SEPT. 23, 1971

3313

M-1
 Department of
 Mines and Petroleum Resources
 ASSESSMENT REPORT
 NO. 3313 MAP #1

SURFACE PROJECTION
 OF ANOMALOUS ZONES
 DEFINITE
 PROBABLE
 POSSIBLE
 Number of the end of anomaly
 indicates electrode interval

KENCO EXPLORATIONS, (WESTERN) LIMITED
 KLI NO. 1 & 2 GROUPS, KLIYUL CREEK AREA
 OMINECA M.D., B.C.
 SCALE
 ONE INCH EQUALS FOUR HUNDRED FEET

LEGEND
 ANOMALOUS IP ZONES

