

93L/16W  
REPORT ON THE  
INDUCED POLARIZATION  
AND RESISTIVITY SURVEY  
ON THE

CORTINA GRID, BABINE LAKE AREA,  
OMINECA MINING DIVISION, B. C.  
FOR  
NITTETSU MINING COMPANY LIMITED

BY

MARION A. GOUDIE, B.Sc.

AND

PHILIP G. HALLOF, Ph.D.

NAME AND LOCATION OF PROPERTY  
CORTINA GRID, BABINE LAKE AREA,  
OMINECA MINING DIVISION, B.C. 54°N, 126°W - NE  
DATE STARTED - AUGUST 8, 1971  
DATE FINISHED - SEPTEMBER 6, 1971

TABLE OF CONTENTS

<u>Part A:</u>	Notes on theory and field procedure	9 pages	
<u>Part B:</u>	Report	8 pages	<u>Page</u>
1.	Introduction		1
2.	Presentation of Results		2
3.	Discussion of Results		3
4.	Conclusions		3
5.	Assessment Details		5
6.	Statement of Cost		6
7.	Certificate - Marion A. Cowlio		7
8.	Certificate - Philip G. Hallof		8
9.	Appendix		
<u>Part C:</u>	Illustrations	8 pieces	
# 1	Plan Map (in pocket)	Dwg. I.P.P. 3505	
2 - 8	IP Data Plots	Dwg. IP 5851-1 to -7	
9	Claim Map (in pocket)		

# McPHAR GEOPHYSICS

## NOTES ON THE THEORY, METHOD OF FIELD OPERATION AND PRESENTATION OF DATA FOR THE INDUCED POLARIZATION METHOD

---

Induced Polarization as a geophysical measurement refers to the blocking action or polarization of metallic or electronic conductors in a medium of ionic solution conduction.

This electro-chemical phenomenon occurs wherever electrical current is passed through an area which contains metallic minerals such as base metal sulphides. Normally, when current is passed through the ground, as in resistivity measurements, all of the conduction takes place through ions present in the water content of the rock, or soil, i. e. by ionic conduction. This is because almost all minerals have a much higher specific resistivity than ground water. The group of minerals commonly described as "metallic", however, have specific resistivities much lower than ground waters. The induced polarization effect takes place at those interfaces where the mode of conduction changes from ionic in the solutions filling the interstices of the rock to electronic in the metallic minerals present

in the rock.

The blocking action or induced polarization mentioned above, which depends upon the chemical energies necessary to allow the ions to give up or receive electrons from the metallic surface, increases with the time that a d. c. current is allowed to flow through the rock; i. e. as ions pile up against the metallic interface the resistance to current flow increases. Eventually, there is enough polarization in the form of excess ions at the interfaces, to appreciably reduce the amount of current flow through the metallic particle. This polarization takes place at each of the infinite number of solution-metal interfaces in a mineralized rock.

When the d. c. voltage used to create this d. c. current flow is cut off, the Coulomb forces between the charged ions forming the polarization cause them to return to their normal position. This movement of charge creates a small current flow which can be measured on the surface of the ground as a decaying potential difference.

From an alternate viewpoint it can be seen that if the direction of the current through the system is reversed repeatedly before the polarization occurs, the effective resistivity of the system as a whole will change as the frequency of the switching is changed. This is a consequence of the fact that the amount of current flowing through each metallic interface depends upon the length of time that current has been passing through it in one direction.

The values of the per cent frequency effect or F. E. are a measurement of the polarization in the rock mass. However, since the measurement of the degree of polarization is related to the apparent resistivity of the rock mass it is found that the metal factor values or M. F. are the most useful values in determining the amount of polarization present in the rock mass. The MF values are obtained by normalizing the F. E. values for varying resistivities.

The induced polarization measurement is perhaps the most powerful geophysical method for the direct detection of metallic sulphide mineralization, even when this mineralization is of very low concentration. The lower limit of volume per cent sulphide necessary to produce a recognizable IP anomaly will vary with the geometry and geologic environment of the source, and the method of executing the survey. However, sulphide mineralization of less than one per cent by volume has been detected by the IP method under proper geological conditions.

The greatest application of the IP method has been in the search for disseminated metallic sulphides of less than 20% by volume. However, it has also been used successfully in the search for massive sulphides in situations where, due to source geometry, depth of source, or low resistivity of surface layer, the EM method can not be successfully applied. The ability to differentiate ionic conductors, such as water filled shear zones, makes the IP method a useful tool in checking EM

anomalies which are suspected of being due to these causes.

In normal field applications the IP method does not differentiate between the economically important metallic minerals such as chalcopyrite, chalcocite, molybdenite, galena, etc., and the other metallic minerals such as pyrite. The induced polarization effect is due to the total of all electronic conducting minerals in the rock mass. Other electronic conducting materials which can produce an IP response are magnetite, pyrolusite, graphite, and some forms of hematite.

In the field procedure, measurements on the surface are made in a way that allows the effects of lateral changes in the properties of the ground to be separated from the effects of vertical changes in the properties. Current is applied to the ground at two points in distance (X) apart. The potentials are measured at two other points (X) feet apart, in line with the current electrodes is an integer number (n) times the basic distance (X).

The measurements are made along a surveyed line, with a constant distance (nX) between the nearest current and potential electrodes. In most surveys, several traverses are made with various values of (n); i. e. (n) = 1, 2, 3, 4, etc. The kind of survey required (detailed or reconnaissance) decides the number of values of (n) used.

In plotting the results, the values of the apparent resistivity, apparent per cent frequency effect, and the apparent metal factor

measured for each set of electrode positions are plotted at the intersection of grid lines, one from the center point of the current electrodes and the other from the center point of the potential electrodes. (See Figure A.) The resistivity values are plotted above the line as a mirror image of the metal factor values below. On a second line, below the metal factor values, are plotted the values of the per cent frequency effect. In some cases the values of per cent frequency effect are plotted as superscripts of the metal factor value. In this second case the frequency effect values are not contoured. The lateral displacement of a given value is determined by the location along the survey line of the center point between the current and potential electrodes. The distance of the value from the line is determined by the distance ( $nX$ ) between the current and potential electrodes when the measurement was made.

The separation between sender and receiver electrodes is only one factor which determines the depth to which the ground is being sampled in any particular measurement. The plots then, when contoured, are not section maps of the electrical properties of the ground under the survey line. The interpretation of the results from any given survey must be carried out using the combined experience gained from field results, model study results and theoretical investigations. The position of the electrodes when anomalous values are measured is important in the interpretation.

In the field procedure, the interval over which the potential differences are measured is the same as the interval over which the electrodes are moved after a series of potential readings has been made. One of the advantages of the induced polarization method is that the same equipment can be used for both detailed and reconnaissance surveys merely by changing the distance (X) over which the electrodes are moved each time. In the past, intervals have been used ranging from 25 feet to 2000 feet for (X). In each case, the decision as to the distance (X) and the values of (n) to be used is largely determined by the expected size of the mineral deposit being sought, the size of the expected anomaly and the speed with which it is desired to progress.

The diagram in Figure A demonstrates the method used in plotting the results. Each value of the apparent resistivity, apparent metal factor, and apparent per cent frequency effect is plotted and identified by the position of the four electrodes when the measurement was made. It can be seen that the values measured for the larger values of (n) are plotted farther from the line indicating that the thickness of the layer of the earth that is being tested is greater than for the smaller values of (n); i. e. the depth of the measurement is increased. When the F. E. values are plotted as superscripts to the MF values the third section of data values is not presented and the F. E. values are not contoured.



The actual data plots included with the report are prepared utilizing an IBM 360/75 Computer and a Calcomp 770/763 Incremental Plotting System. The data values are calculated, plotted, and contoured according to a programme developed by McPhar Geophysics. Certain symbols have been incorporated into the programme to explain various situations in recording the data in the field.

The IP measurement is basically obtained by measuring the difference in potential or voltage ( $\Delta V$ ) obtained at two operating frequencies. The voltage is the product of the current through the ground and the apparent resistivity of the ground. Therefore in field situations where the current is very low due to poor electrode contact, or the apparent resistivity is very low, or a combination of the two effects; the value of ( $\Delta V$ ) the change in potential will be too small to be measurable. The symbol "TL" on the data plots indicates this situation.

In some situations spurious noise, either man made or natural, will render it impossible to obtain a reading. The symbol "N" on the data plots indicates a station at which it is too noisy to record a reading. If a reading can be obtained, but for reasons of noise there is some doubt as to its accuracy, the reading is bracketed in the data plot ( ).

In certain situations negative values of Apparent Frequency Effect are recorded. This may be due to the geologic environment or spurious electrical effects. The actual negative frequency effect value recorded is indicated on the data plot, however the symbol "NEG" is

indicated for the corresponding value of Apparent Metal Factor. In contouring negative values the contour lines are indicated to the nearest positive value in the immediate vicinity of the negative value.

The symbol "NR" indicates that for some reason the operator did not attempt to record a reading although normal survey procedures would suggest that one was required. This may be due to inaccessible topography or other similar reasons. Any symbol other than those discussed above is unique to a particular situation and is described within the body of the report.

# METHOD USED IN PLOTTING DIPOLE-DIPOLE INDUCED POLARIZATION AND RESISTIVITY RESULTS

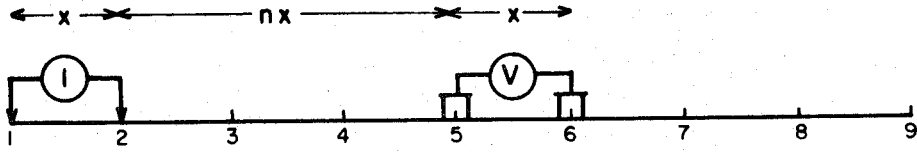

Stations on line

$x$  = Electrode spread length  
 $n$  = Electrode separation

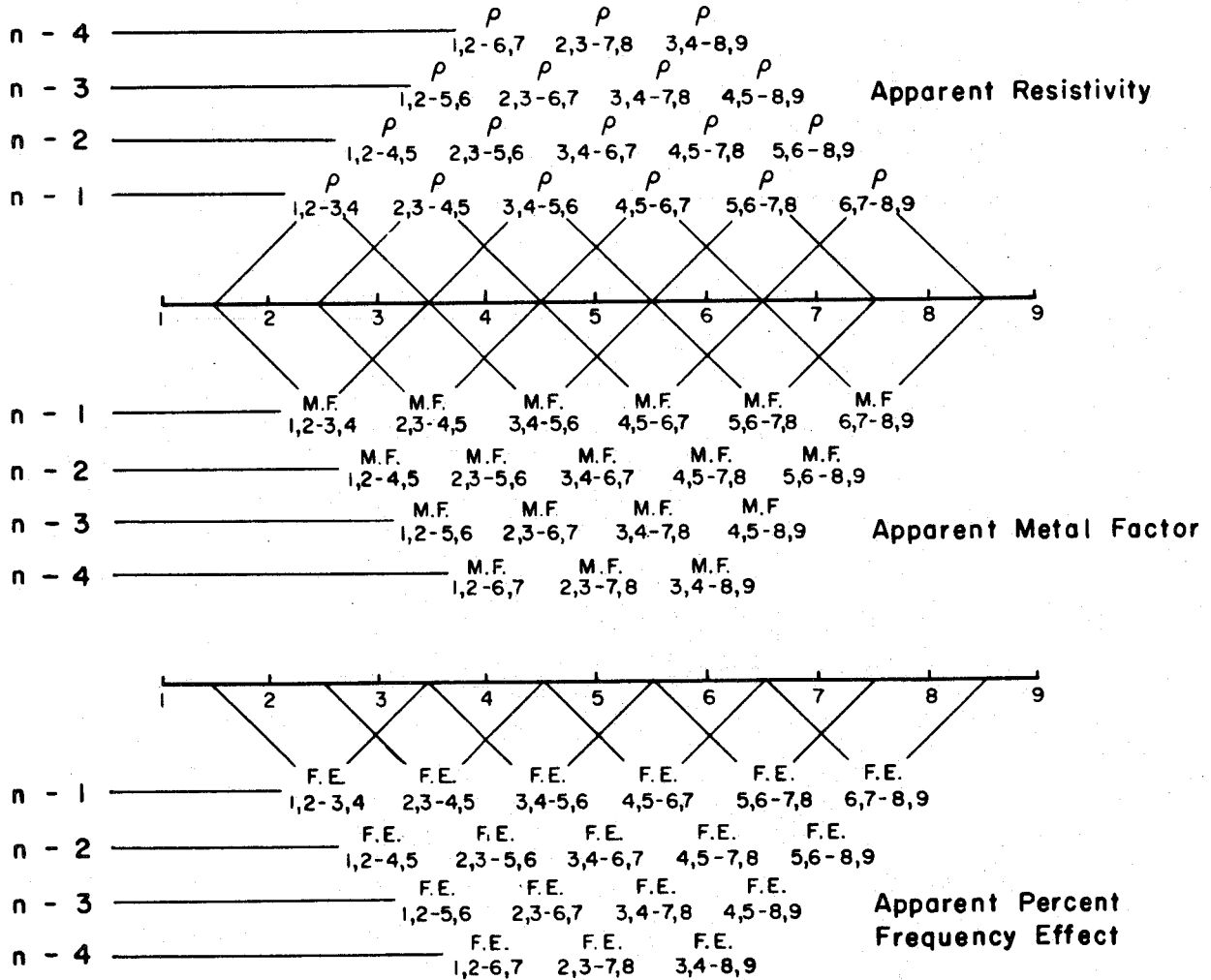

Fig. A

**McPHAR GEOPHYSICS LIMITED**

**REPORT ON THE  
INDUCED POLARIZATION  
AND RESISTIVITY SURVEY  
ON THE  
CORTINA GRID, BABINE LAKE AREA,  
OMINECA MINING DIVISION, B.C.  
FOR  
NITTETSU MINING COMPANY LIMITED**

---

**1. INTRODUCTION**

At the request of the company, an Induced Polarization and Resistivity survey has been completed on the Cortina Grid, Babine Lake area in the Omineca Mining Division, British Columbia, for Nittetsu Mining Company Limited. The Cortina claims are situated in the northeast quadrant of the 1° quadrilateral whose southeast corner is at 54°N latitude and 126°W longitude.

The survey area is drift covered. Undivided volcanic rocks of Mesozoic age have been mapped to the east and north of the grid. The IP survey was carried out to locate any sources of metallic mineralization in the area which would be of economic interest.

The work was done in August, 1971, using a McPhar P660 high power variable frequency IP unit over the following claims:

8, 10, 12, 14, 33, 34, 37, 38, 39,  
40, 41, 42, 45, 47, 49, 50, 51, 52.

These claims are assumed to be owned or held under option by  
Nittetsu Mining Company Limited.

## 2. PRESENTATION OF RESULTS

The Induced Polarization and Resistivity results are shown on the  
following data plots in the manner described in the notes preceding this report.

<u>Line</u>	<u>Electrode Intervals</u>	<u>Dwg. No.</u>
2400W	200 feet	IP 5851-1
1600W	200 feet	IP 5851-2
800W	200 feet	IP 5851-3
0	200 feet	IP 5851-4
800E	200 feet	IP 5851-5
1600E	200 feet	IP 5851-6
2400E	200 feet	IP 5851-7

Also enclosed with this report is Dwg. I. P. P. 3505, a plan map of  
the Cortina Grid at a scale of 1" = 400'. The definite, probable and possible  
Induced Polarization anomalies are indicated by bars, in the manner shown  
on the legend, on this plan map as well as on the data plots. These bars  
represent the surface projection of the anomalous zones as interpreted from  
the location of the transmitter and receiver electrodes when the anomalous  
values were measured.

Since the Induced Polarization measurement is essentially an  
averaging process, as are all potential methods, it is frequently difficult

to exactly pinpoint the source of an anomaly. Certainly, no anomaly can be located with more accuracy than the electrode interval length; i. e. when using 200' electrode intervals the position of a narrow sulphide body can only be determined to lie between two stations 200' apart. In order to definitely locate, and fully evaluate, a narrow, shallow source it is necessary to use shorter electrode intervals. In order to locate sources at some depth, larger electrode intervals must be used, with a corresponding increase in the uncertainties of location. Therefore, while the centre of the indicated anomaly probably corresponds fairly well with source, the length of the indicated anomaly along the line should not be taken to represent the exact edges of the anomalous material.

### 3. DISCUSSION OF RESULTS

The IP survey located anomalies on all lines of the survey. These anomalies are, in general, low in magnitude and are typical of the pattern given by disseminated metallic mineralization. The anomalies are broad on Line 0 and Line 800W, but become discontinuous to the east and west of these two lines. The source of the anomalies is generally shallow; i. e. less than 1 electrode unit (200') deep, with some depth extent indicated. If the area is of interest, detail with shorter electrode intervals would better define the source of the anomalies.

### 4. CONCLUSIONS

The IP survey located an irregular anomalous zone which may represent weakly disseminated metallic mineralization. If these weak

anomalies are of geologic interest, additional work may be warranted (see Appendix). The top of the source is shallow and detail to better locate the source has been suggested. However, should a drill test be desired, the source could be tested at any point between 25 and 4N on Line 0, which crosses the access road.

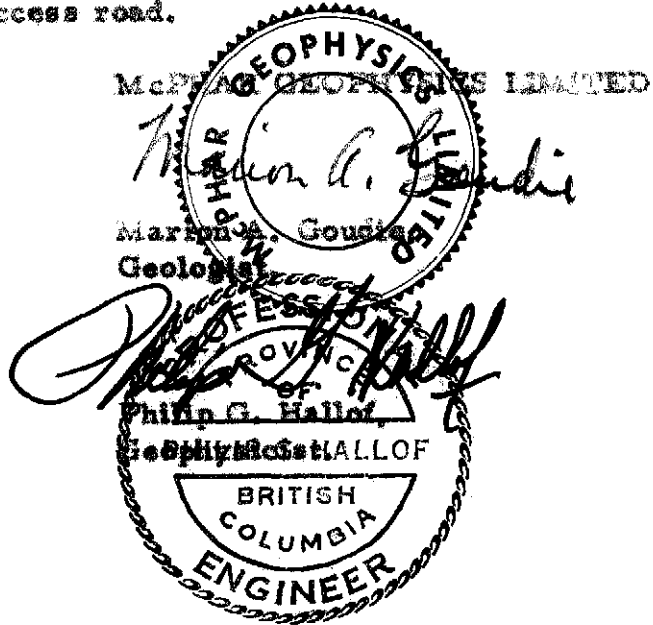

Dated: November 1, 1971

Expiry Date: February 25, 1972

ASSESSMENT DETAILS

PROPERTY: Cortina Grid

MINING DIVISION: Omineca

SPONSOR: Nittetau Mining Company Limited

PROVINCE: British Columbia

LOCATION: Babine Lake Area

TYPE OF SURVEY: Induced Polarization

OPERATING MAN DAYS: 34

DATE STARTED: Aug. 8, 1971

EQUIVALENT 8 HR. MAN DAYS: 51

DATE FINISHED: Sept. 6, 1971

CONSULTING MAN DAYS: 3

NUMBER OF STATIONS: 145

DRAUGHTING MAN DAYS: 5

NUMBER OF READINGS: 1344

TOTAL MAN DAYS: 59

MILES OF LINE SURVEYED: 5.2

**CONSULTANTS:**

Marion A. Goudie, 739 Military Trail, West Hill, Ontario.  
Philip G. Hallof, 11 Barnwood Court, Don Mills, Ontario.

**FIELD TECHNICIANS:**

M. McDonald, 6135 Bow Crescent, N.W. Calgary, Alberta.  
D. Adams, 3127 W. 8th Avenue, Vancouver 8, B.C.  
Plus 3 Extra Labourers:  
M. England, General Delivery, Burns Lake, B.C.  
W. Schiogl, 2129 Skeena Street, Vancouver 12, B.C.  
T. McDonald, 6135 Bow Crescent, N.W. Calgary, Alberta.

**DRAUGHTSMEN:**

V. Young, 703 Cortez Avenue, Bay Ridges, Ontario.  
B. Marr, 19 Kenewen Court, Toronto 16, Ontario.  
N. Lade, 299 Jasper Avenue, Oshawa, Ontario.

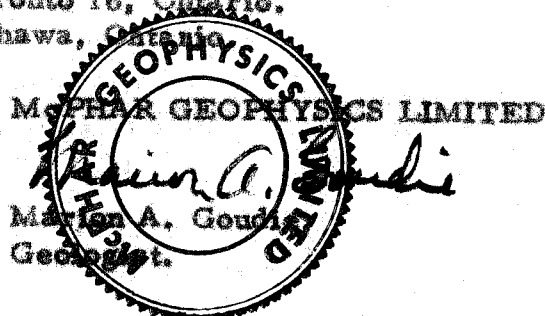

Dated: November 1, 1971



STATEMENT OF COST

*[Signature]*  
Nittetsu Mining Company Limited - Cortina Grid, Babine Lake Area  
Omineca Mining Division, B.C. - IP Survey

Crew: 2 men M. McDonald & D. Adams

8½ days Operating	@ \$250.00 per day	\$2,125.00
½ day Standby	@ \$100.00 per day	50.00
		<u>2,175.00</u>

Expenses - prorated 8½/24½

Fares	32.97	
Meals and Accommodation	125.00	
Vehicle Expense	381.25	
Supplies	22.14	
Telephone and Telegraph	8.81	
	<u>570.17</u>	570.17

Extra Labour		<u>985.52</u>
		<u>\$3,730.69</u>

McPHYSICS LIMITED

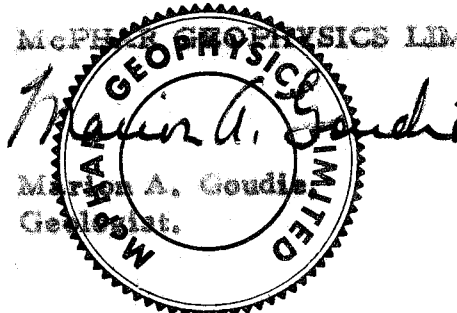

Dated: November 1, 1971

CERTIFICATE

I, Marion A. Goudie, of the City of Toronto, Province of Ontario, do hereby certify that:

1. I am a Geologist residing at 739 Military Trail, West Hill, Ontario.
2. I am a graduate of the University of Western Ontario with a B.Sc. Degree (1950) in Honours Geology.
3. I am a member of the Geological Society of America.
4. I have been practising my profession for 20 years.
5. I have no direct or indirect interest, nor do I expect to receive any interest directly or indirectly, in the property or securities of Nittetsu Mining Company Limited or any affiliate.
6. The statements made in this report are based on a study of published geological literature and unpublished private reports.
7. Permission is granted to use in whole or in part for assessment and qualification requirements but not for advertising purposes.

Dated at Toronto

This 1st day of November 1971

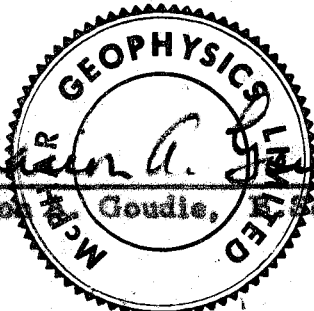
  
Marion A. Goudie  
Marion A. Goudie, B.Sc.

CERTIFICATE

I, Philip George Hallof, of the City of Toronto, Province of Ontario, do hereby certify that:

1. I am a geophysicist residing at 11 Barnwood Court, Don Mills, (Toronto) Ontario.
2. I am a graduate of the Massachusetts Institute of Technology with a B.Sc. Degree (1952) in Geology and Geophysics, and a Ph.D. Degree (1957) in Geophysics.
3. I am a member of the Society of Exploration Geophysicists and the European Association of the Exploration Geophysicists.
4. I am a Professional Geophysicist, registered in the Province of Ontario, the Province of British Columbia and the State of Arizona.
5. I have no direct or indirect interest, nor do I expect to receive any interest directly or indirectly, in the property or securities of Nittetsu Mining Company Limited or any affiliate.
6. The statements made in this report are based on a study of published geological literature and unpublished private reports.
7. Permission is granted to use in whole or in part for assessment and qualification requirements but not for advertising purposes.

Dated at Toronto

This 1st day of November 1971

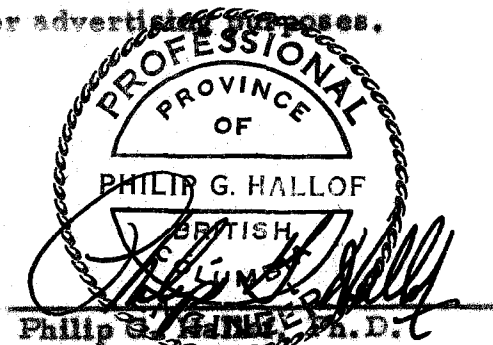

Expiry Date: February 25, 1972

# McPHAR GEOPHYSICS

## APPENDIX

### EXPECTED IP ANOMALIES FROM "PORPHYRY COPPER" TYPE ZONES OF DISSEMINATED SULPHIDE MINERALIZATION

Our experience in other areas has shown that the induced polarization method can be successfully used to locate, and outline, zones of disseminated sulphide mineralization of the "porphyry copper" type. In most cases the interpretation of the IP results is simple and straightforward. The results shown in Figure 1 and Figure 2 are typical.

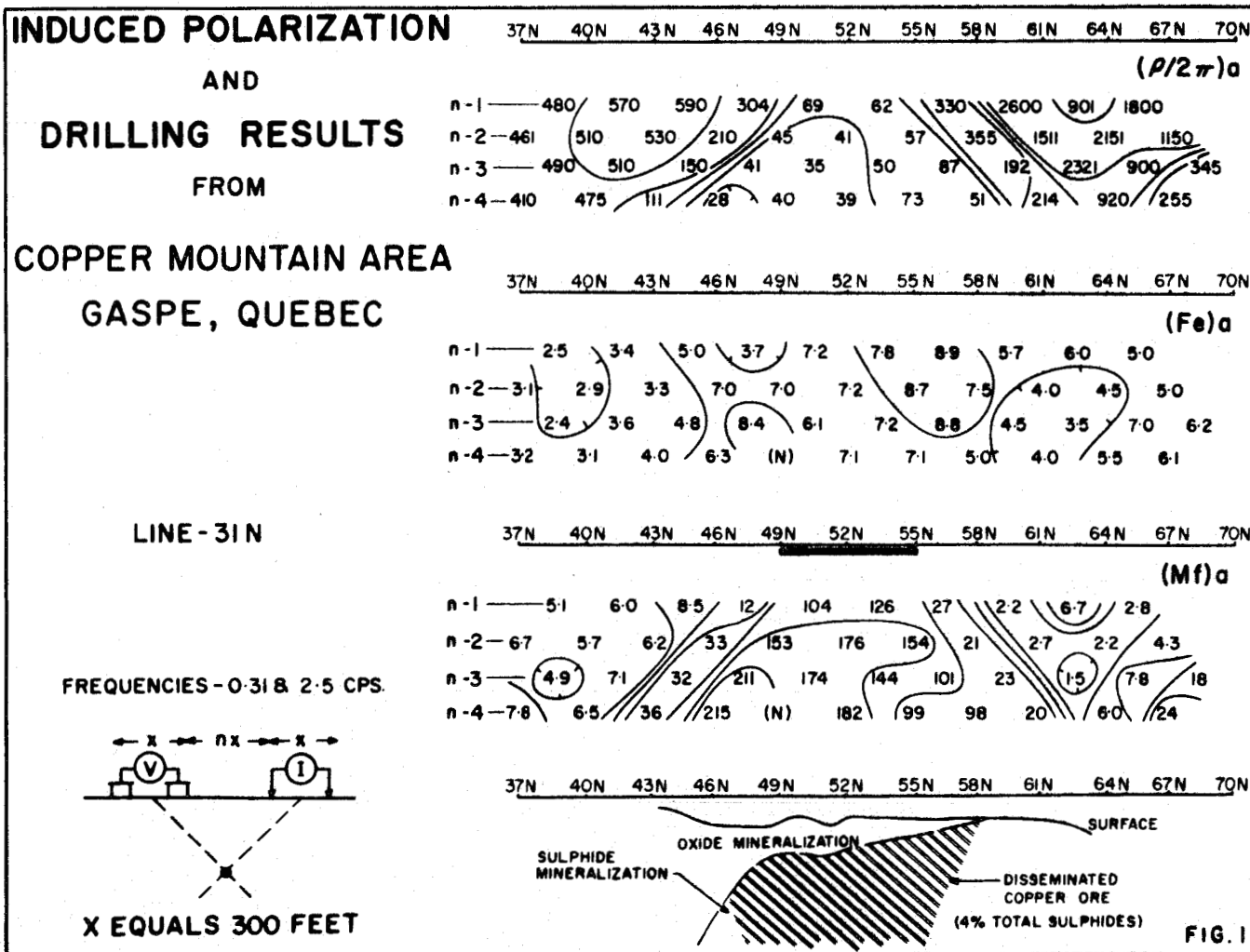

The source of the moderate magnitude IP anomaly shown in Figure 1 contains approximately 4% metallic mineralization. The zone is of limited lateral extent and enough copper is present to make the mineralization "ore grade". The presence of the surface oxidation can be seen in the fact that the apparent IP effects increase for  $n = 2$ .

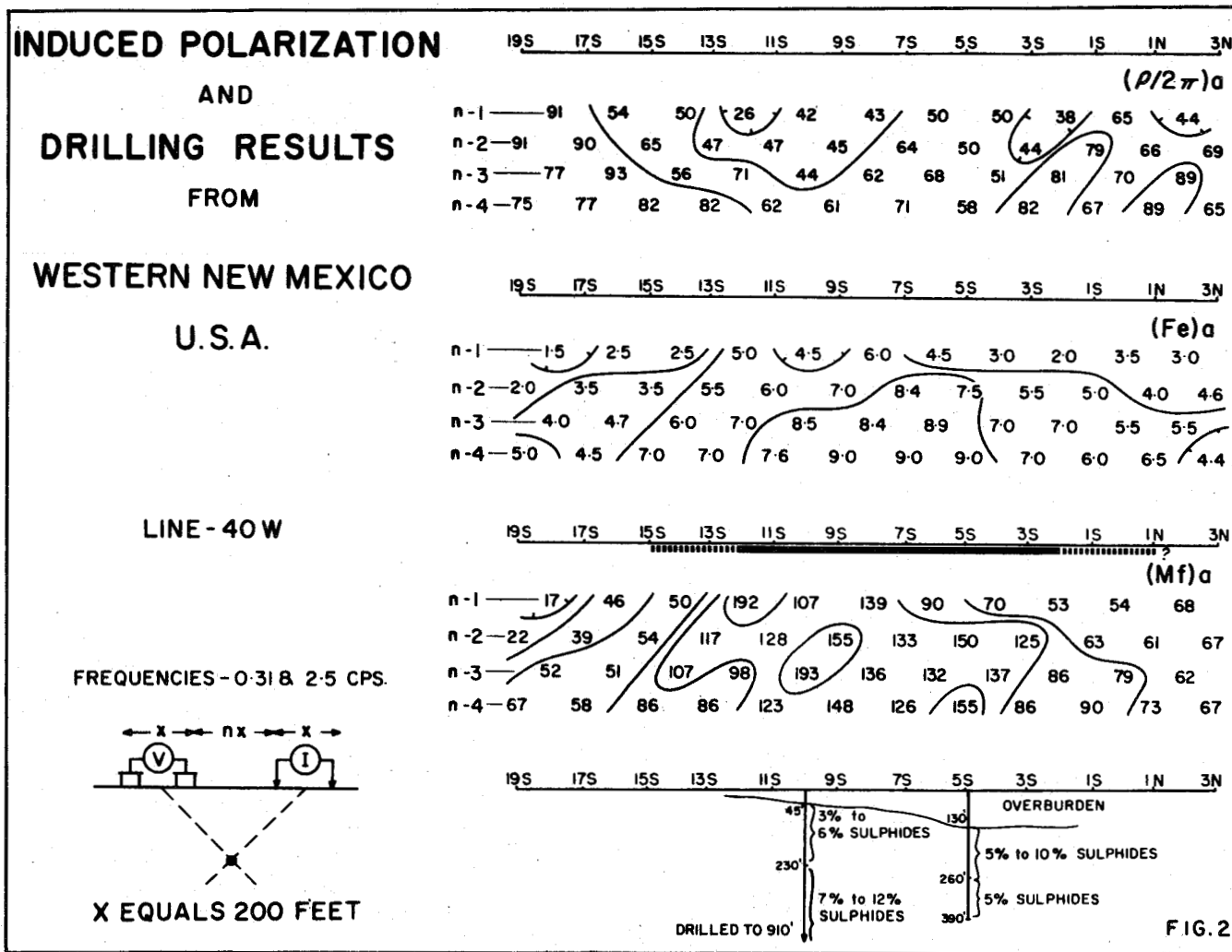

The IP anomaly shown in Figure 2 has about the same magnitude as that described above. It should be noted that appreciably greater concentrations of metallic mineralization are present; further, there is little or no copper present. These results illustrate the fact that IP results can not be used to determine the exact amount of metallic mineralization present or to determine the economic importance of a mineralized zone. In some geologic situations zoning is present; the zones of mineralization of greatest economic value may contain less total metallic mineralization than other zones in the same general area.

In the proper geologic environment, the method will detect even very low concentrations of metallic mineralization. The IP results shown in Figure 3 located the ore zone at the Brenda Property near Peachland, B. C. The zone contains 1.0 to 1.5 per cent metallic mineralization; however, the mineralization is "ore grade" because only molybdenite and chalcocopyrite are present.

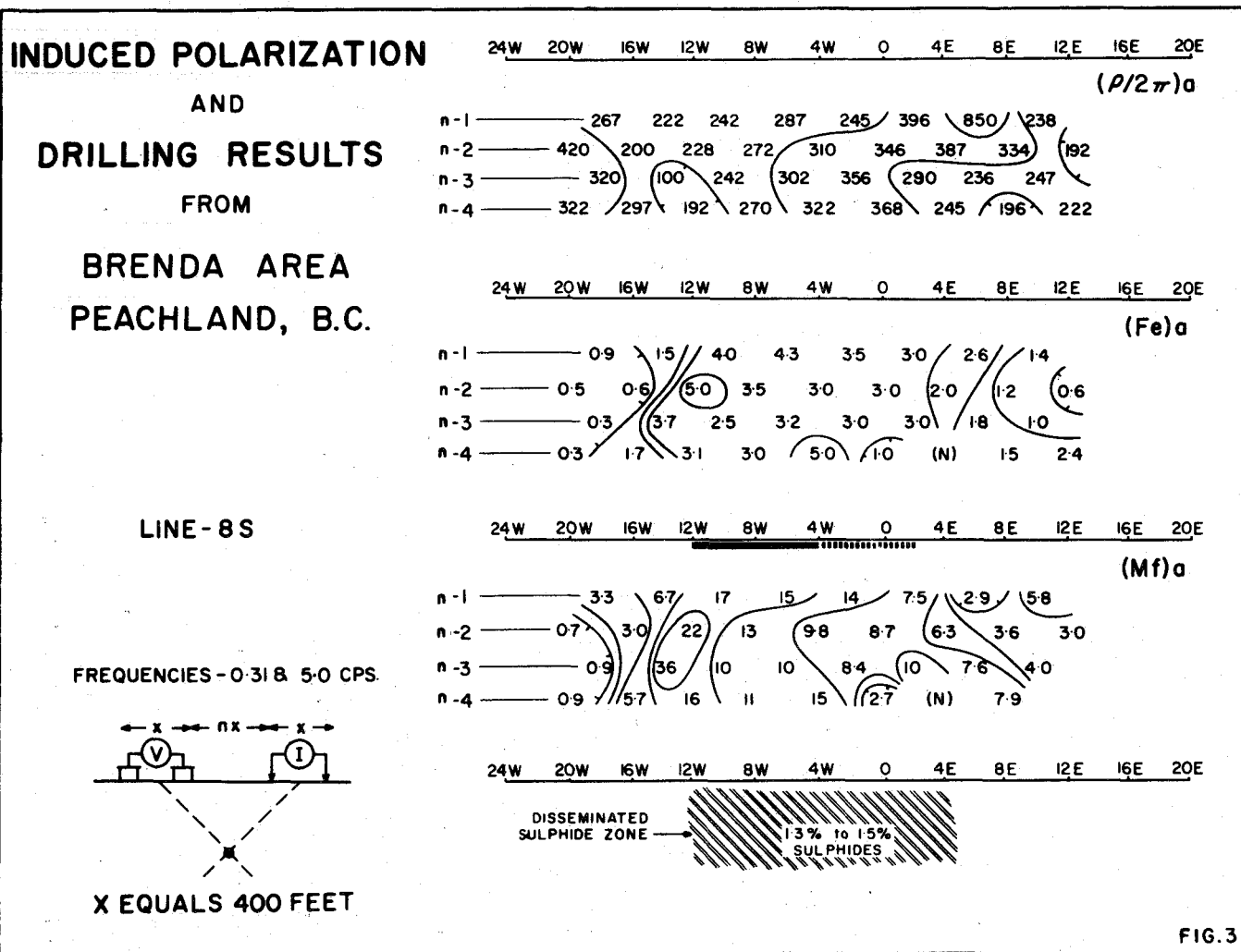
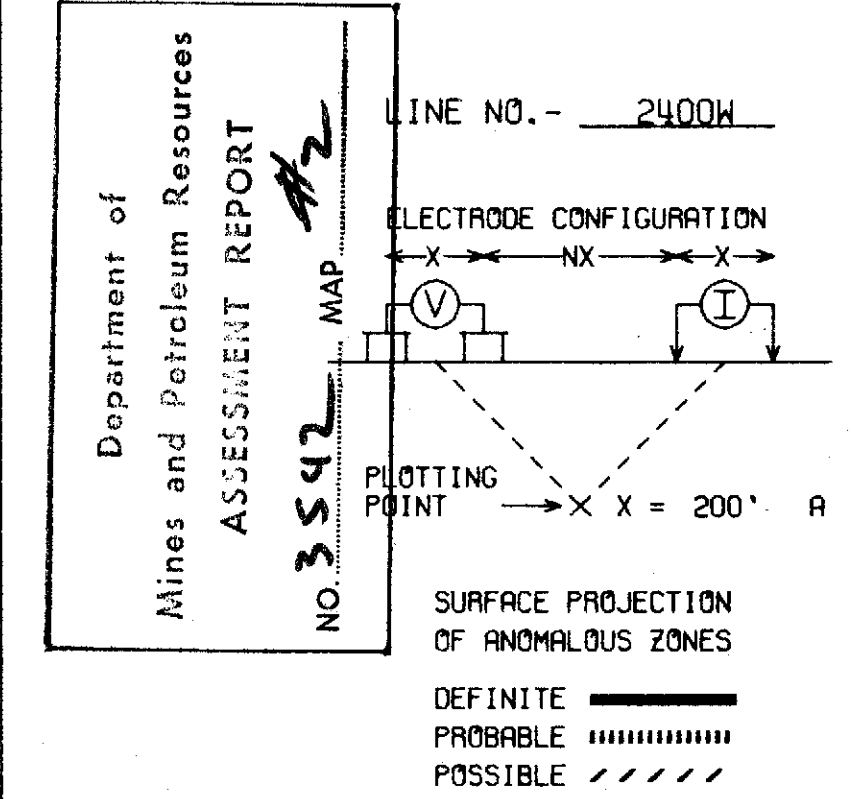

FIG. 3

# NITTETSU MINING CO. LTD.

CORTINA GRID, BABINE LAKE AREA  
OMINECA M.D., B.C.



FREQUENCIES: 0.31-5.0 HZ DATE SURVEYED: JG 1971

NOTE: CONTOURS AT LOGARITHMIC INTERVALS 1.-1.5-2.-3.-5.-7.5-10

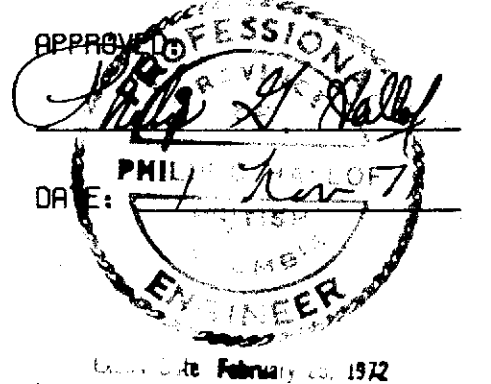

## McPHAR GEOPHYSICS

INDUCED POLARIZATION AND RESISTIVITY SURVEY

NOTE: THIS PLOT WAS PRODUCED WITH AN IBM 360/65 COMPUTER AND A CALCOMP PLOTTER

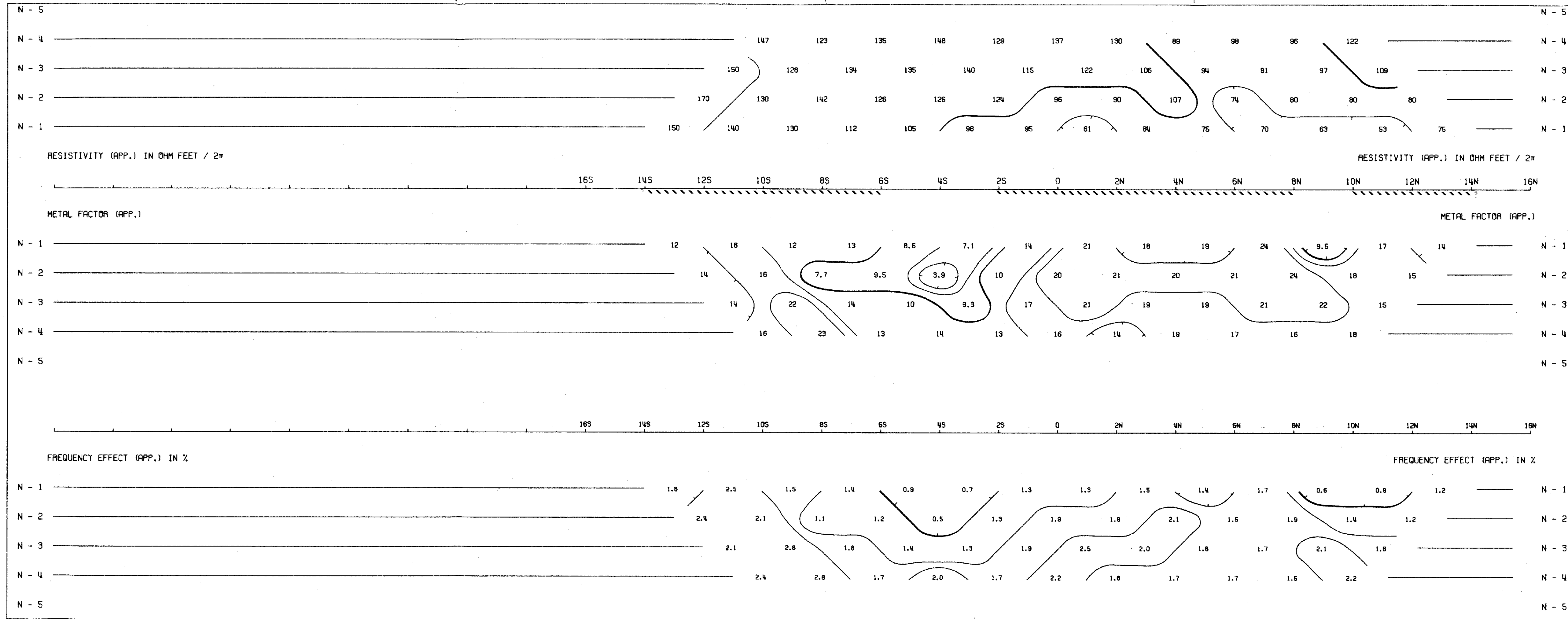

# NITTETSU MINING CO. LTD.

CORTINA GRID, BABINE LAKE AREA  
OMINECA M.D., B.C.

Department of  
Mines and Petroleum Resources  
ASSESSMENT REPORT  
NO. 3542-MAP-13

LINE NO. - 1600W

ELECTRODE CONFIGURATION

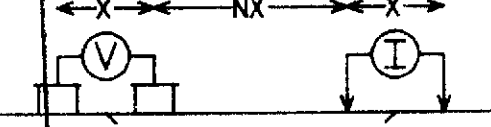

FLOTTING POINT X X = 200'

SURFACE PROJECTION OF ANOMALOUS ZONES

DEFINITE   
PROBABLE   
POSSIBLE

FREQUENCIES: 0.31-5.0 HZ

DATE SURVEYED: AUG 1971

APPROVED:

NOTE: CONTOURS AT LOGARITHMIC INTERVALS  
1.-1.5-2.-3.-5.-7.5-10

DATE: 1 Nov 71

## McPHAR GEOPHYSICS

INDUCED POLARIZATION AND RESISTIVITY SURVEY

NOTE: THIS PLOT WAS PRODUCED WITH AN IBM 360/85 COMPUTER AND A CALCOMP PLOTTER

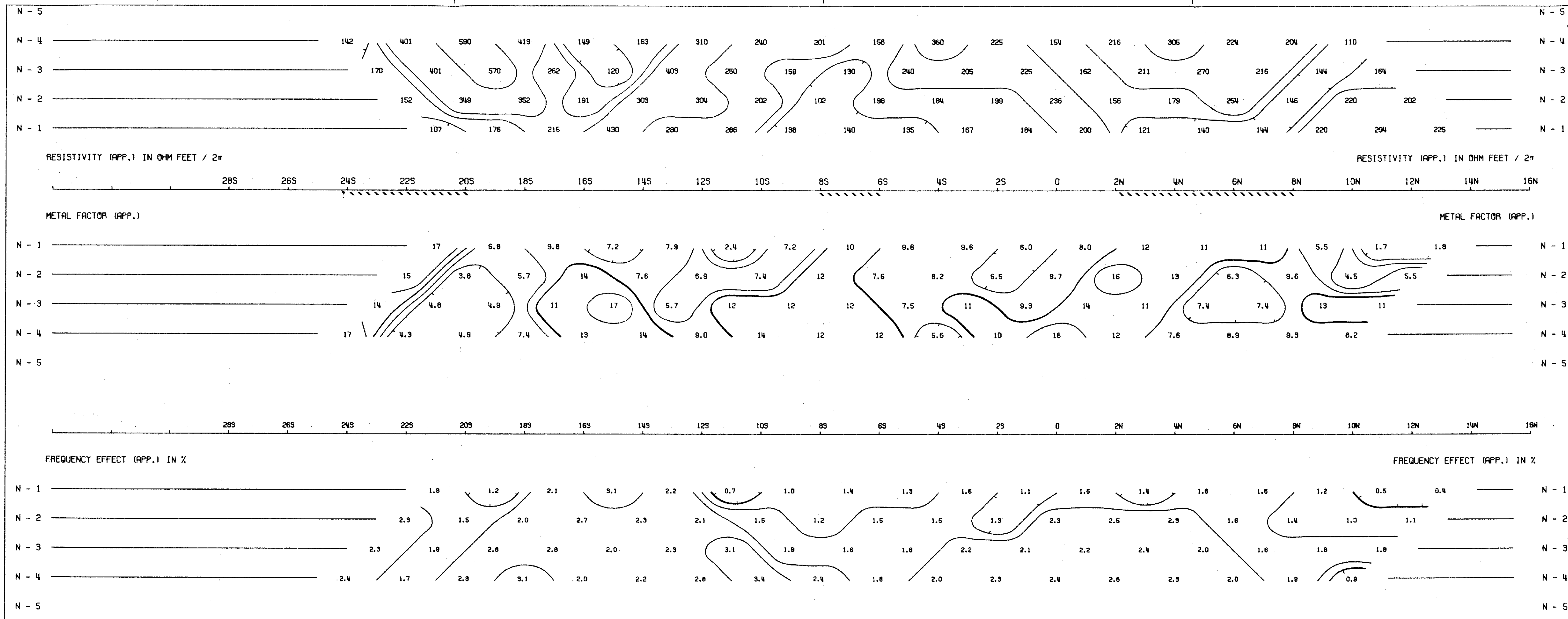



# NITTETSU MINING CO. LTD.

CORTINA GRID, BABINE LAKE AREA  
OMINECA M.D., B.C.

Department of  
Mines and Petroleum Resources  
ASSESSMENT REPORT  
NO. 3542 MAP #4

LINE NO. - 800W

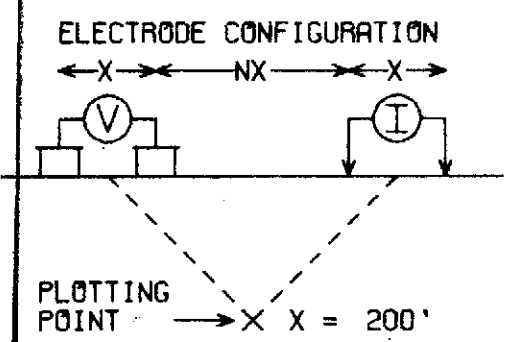

SURFACE PROJECTION  
OF ANOMALOUS ZONES  
DEFINITE **————**  
PROBABLE **|||||**  
POSSIBLE **////**

FREQUENCIES: 0.31-5.0 HZ

DATE SURVEYED: AUG 1971

APPROVED: *Philip H. Kelly*  
DATE: *9/1/71*  
ENGINEER  
Exp. Date: February 25, 1972

NOTE: CONTOURS AT  
LOGARITHMIC INTERVALS  
1.-1.5-2.-3.-5.-7.5-10

## McPHAR GEOPHYSICS

INDUCED POLARIZATION AND RESISTIVITY SURVEY

NOTE: THIS PLOT WAS PRODUCED WITH AN IBM 360/65 COMPUTER AND A CALCOMP PLOTTER

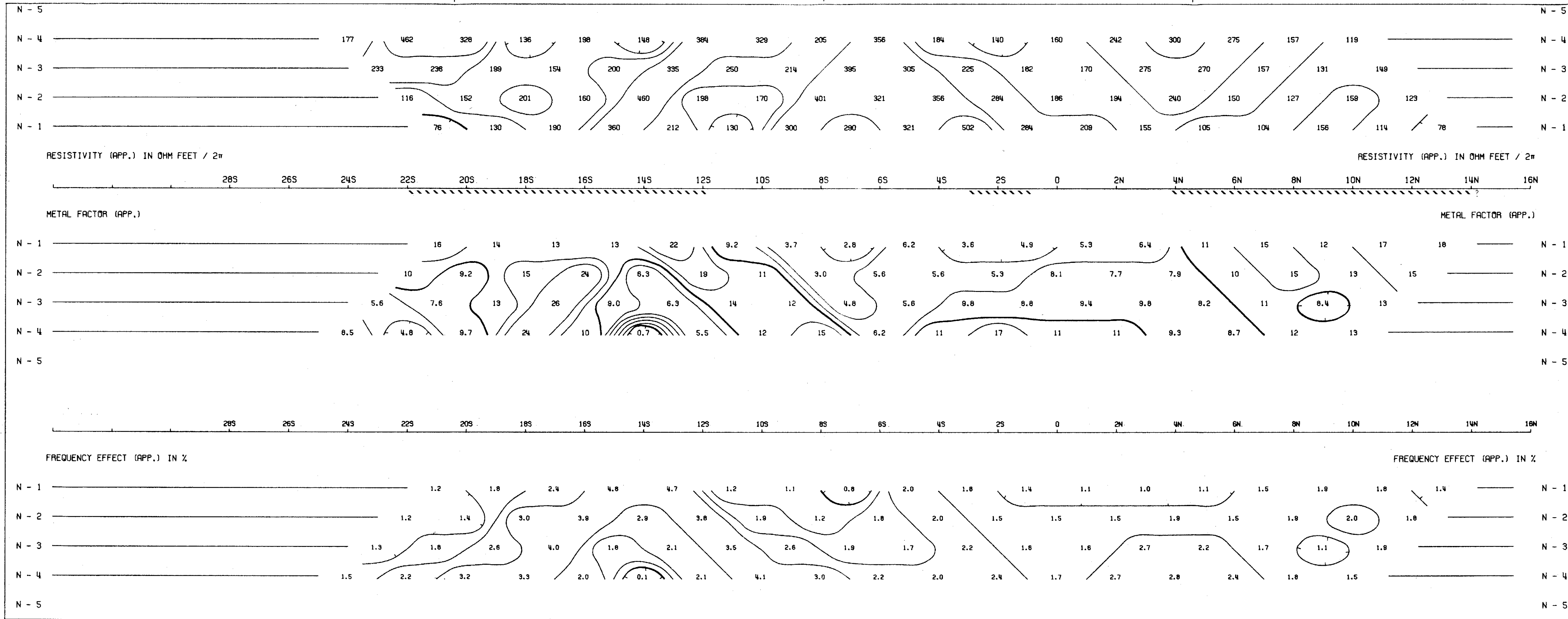

# NITTETSU MINING CO. LTD.

CORTINA GRID, BABINE LAKE AREA  
OMINECA M.D., B.C.

Department of  
Mines and Petroleum Resources  
ASSESSMENT REPORT  
NO. 3542 MAP #5

LINE NO. - 0

ELECTRODE CONFIGURATION

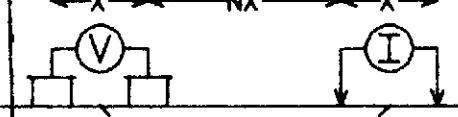

PLOTTING POINT  
X X = 200'

SURFACE PROJECTION  
OF ANOMALOUS ZONES

DEFINITE **————**  
PROBABLE **—————**  
POSSIBLE **///////**

FREQUENCIES: 0.31-5.0 HZ

DATE SURVEYED: AUG 1971

APPROVED: *Philip J. Kelly*

DATE: 1 Nov 71

NOTE: CONTOURS AT  
LOGARITHMIC INTERVALS  
1.-1.5-2.-3.-5.-7.5-10

## McPHAR GEOPHYSICS

INDUCED POLARIZATION AND RESISTIVITY SURVEY

NOTE: THIS PLOT WAS PRODUCED WITH AN IBM 360/65 COMPUTER AND A CALCOMP PLOTTER

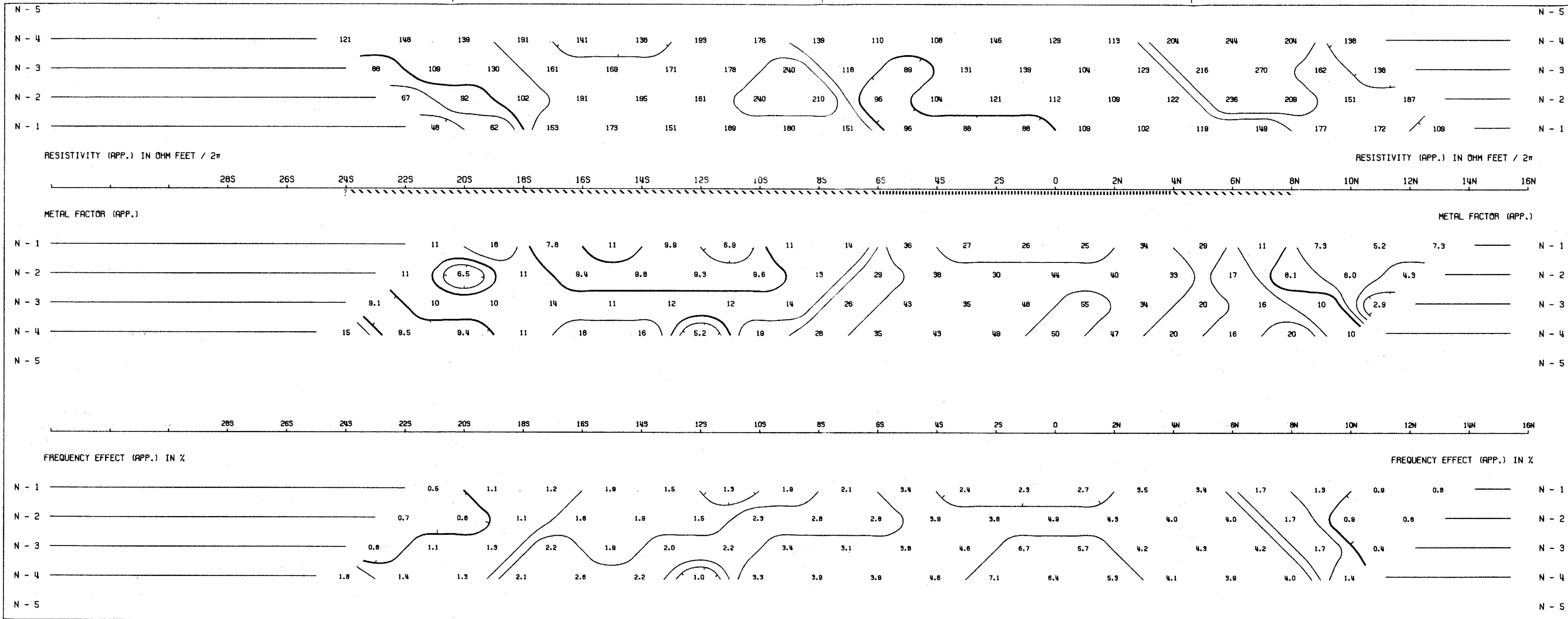



# NITTETSU MINING CO. LTD.

CORTINA GRID, BABINE LAKE AREA  
OMINECA M.O., B.C.

Department of  
Mines and Petroleum Resources  
ASSESSMENT REPORT  
NO. 3542 MAP #7

LINE NO. - 1600E

ELECTRODE CONFIGURATION

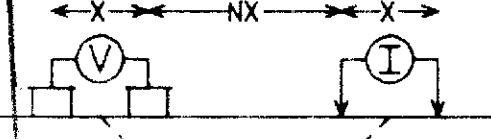

PLOTTING POINT X X = 200'

SURFACE PROJECTION OF ANOMALOUS ZONES

DEFINITE **————**  
PROBABLE **|||||**  
POSSIBLE **////**

FREQUENCIES: 0.31-5.0 HZ

DATE SURVEYED: AUG 1971

APPROVED: *Philip G. Hall*  
PHILIP G. HALL OF  
COLUMBIA  
ENGINEER  
Expiry Date: February 25, 1972

NOTE: CONTOURS AT LOGARITHMIC INTERVALS 1.-1.5-2.-3.-5.-7.5-10

## McPHAR GEOPHYSICS

INDUCED POLARIZATION AND RESISTIVITY SURVEY

NOTE: THIS PLOT WAS PRODUCED WITH AN IBM 360/65 COMPUTER AND A CALCOMP PLOTTER

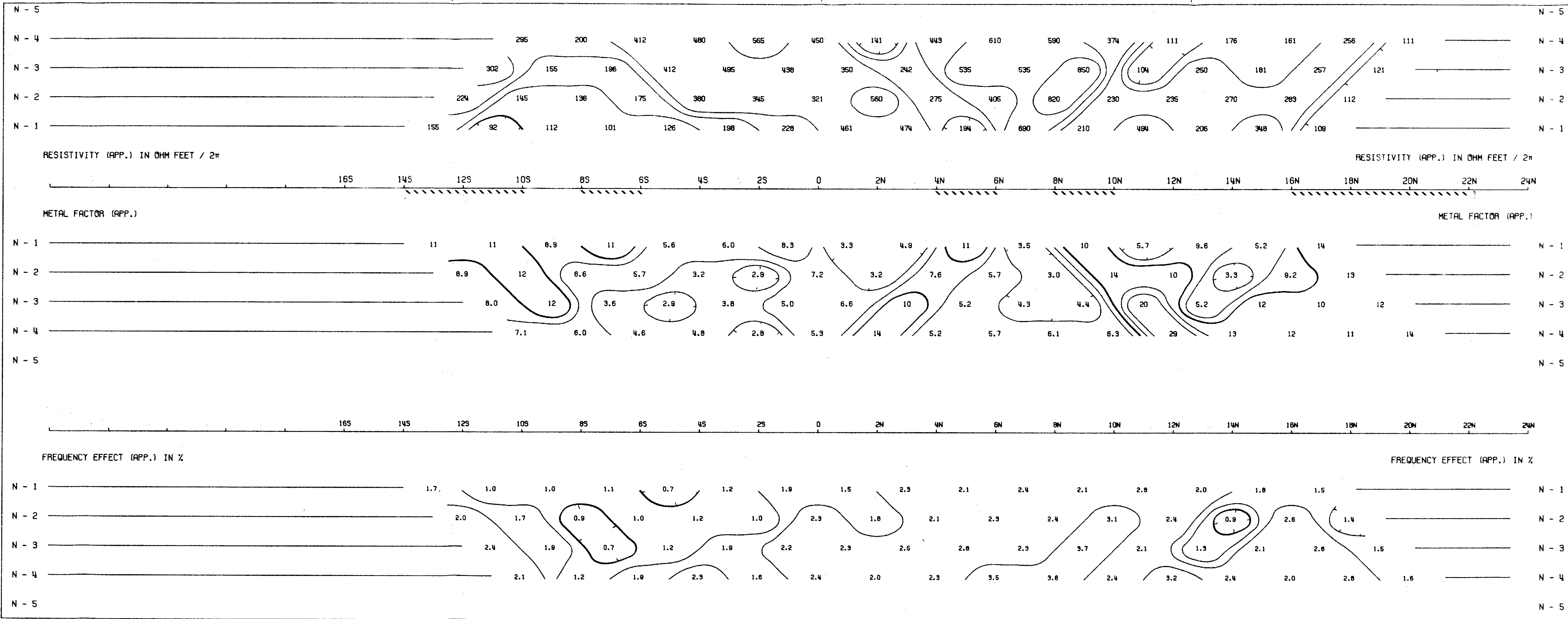

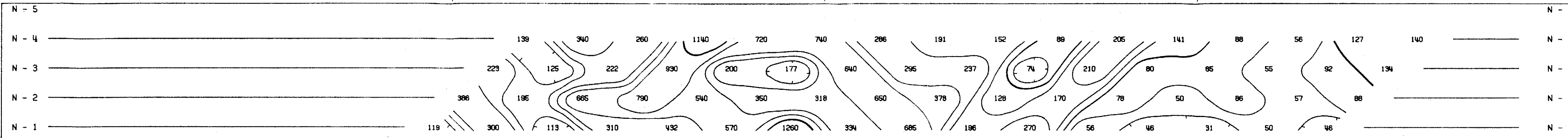

RESISTIVITY (APP.) IN OHM FEET / 2π

RESISTIVITY (APP.) IN OHM FEET / 2π

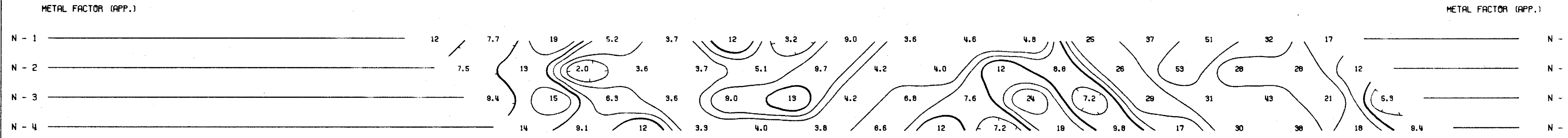
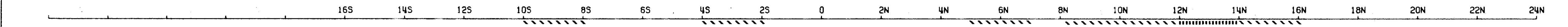

METAL FACTOR (APP.)

METAL FACTOR (APP.)

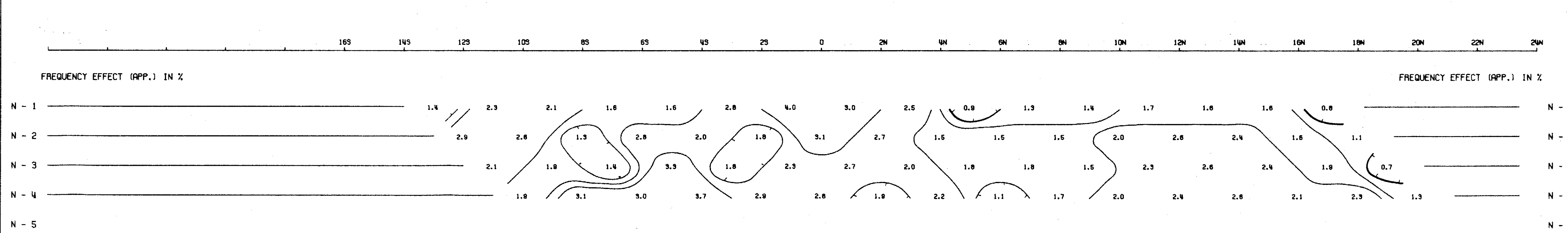

FREQUENCY EFFECT (APP.) IN %

FREQUENCY EFFECT (APP.) IN %



**NITTETSU MINING CO. LTD.**

CORTINA GRID, BABINE LAKE AREA  
OMINECA M.D., B.C.

Department of  
Mines and Petroleum Resources  
**ASSESSMENT REPORT**  
NO. 3542 MAP #8

LINE NO. - 2400E

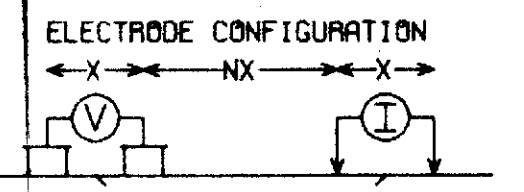

PLOTTING POINT → X X = 200'

SURFACE PROJECTION OF ANOMALOUS ZONES

DEFINITE —————  
PROBABLE - - - - -  
POSSIBLE / / / / /

FREQUENCIES: 0.31-5.0 HZ

DATE SURVEYED: AUG 1971

NOTE: CONTOURS AT LOGARITHMIC INTERVALS 1.-1.5-2.-3.-5.-7.5-10

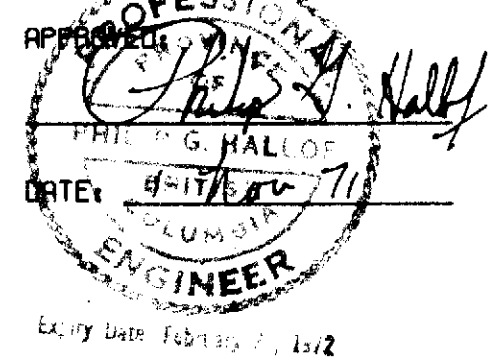

**McPHAR GEOPHYSICS**

INDUCED POLARIZATION AND RESISTIVITY SURVEY

NOTE: THIS PLOT WAS PRODUCED WITH AN IBM 360/65 COMPUTER AND A CALCOMP PLOTTER



# NITTETSU MINING CO. LTD.

CORTINA GRID, BABINE LAKE AREA  
OMINECA M.D., B.C.

Department of  
Mines and Petroleum Resources  
ASSESSMENT REPORT  
NO. 3542 MAP

LINE NO. - 2400W

ELECTRODE CONFIGURATION

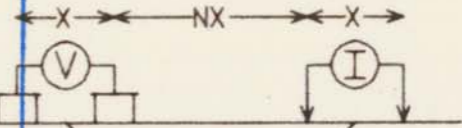

PLOTTING POINT  
X X = 200' A

SURFACE PROJECTION  
OF ANOMALOUS ZONES

DEFINITE   
PROBABLE   
POSSIBLE

FREQUENCIES: 0.31-5.0 HZ

DATE SURVEYED: UG 1971

NOTE: CONTOURS AT  
LOGARITHMIC INTERVALS  
1.-1.5-2.-3.-5.-7.5-10

APPROVED  
  
PHILIP J. LOFT  
ENGINEER  
DATE: February 10, 1972

## McPHAR GEOPHYSICS

INDUCED POLARIZATION AND RESISTIVITY SURVEY

NOTE: THIS PLOT WAS PRODUCED WITH AN IBM 360/65 COMPUTER AND A CALCOMP PLOTTER

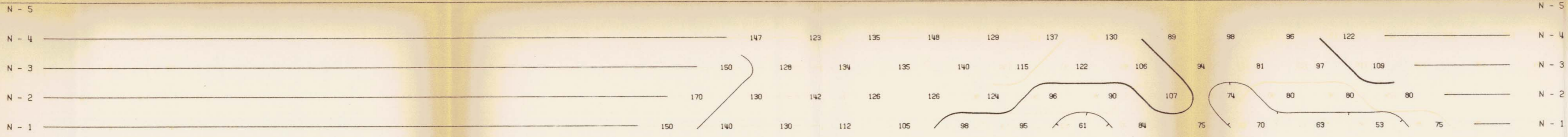

RESISTIVITY (APP.) IN OHM FEET / 2π

RESISTIVITY (APP.) IN OHM FEET / 2π

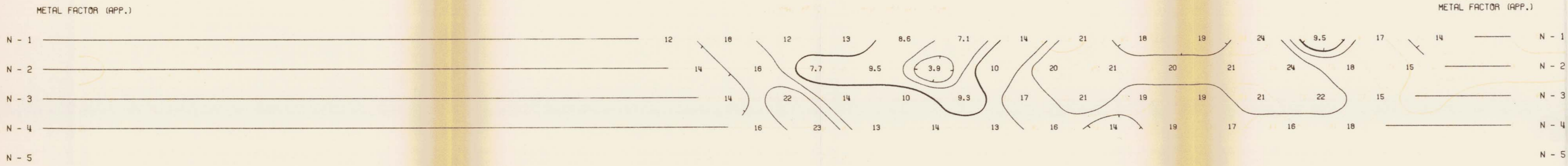

METAL FACTOR (APP.)

METAL FACTOR (APP.)

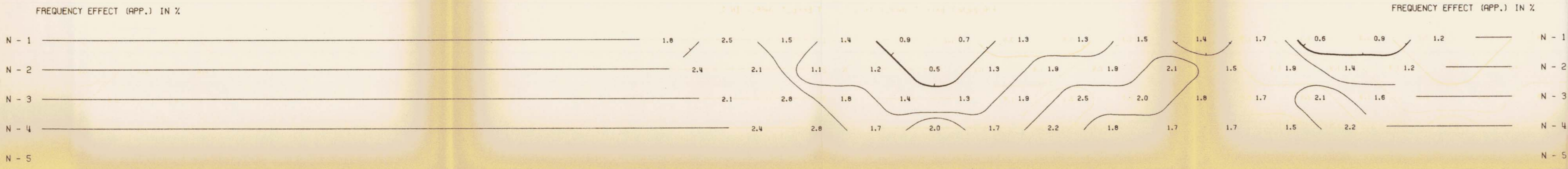

FREQUENCY EFFECT (APP.) IN %

FREQUENCY EFFECT (APP.) IN %



# NITTETSU MINING CO. LTD.

CORTINA GRID, BABINE LAKE AREA  
OMINECA M.D., B.C.

Department of  
Mines and Petroleum Resources  
ASSESSMENT REPORT  
NO. 3542-MAP-13

LINE NO. - 1600W

ELECTRODE CONFIGURATION

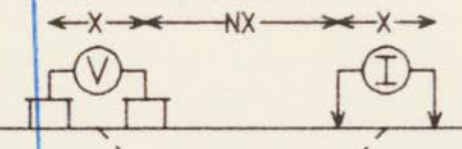

PLOTTING POINT X X = 200'

SURFACE PROJECTION OF ANOMALOUS ZONES

DEFINITE   
PROBABLE   
POSSIBLE

FREQUENCIES: 0.31-5.0 HZ

DATE SURVEYED: AUG 1971

APPROVED:

DATE: 1 Nov 71

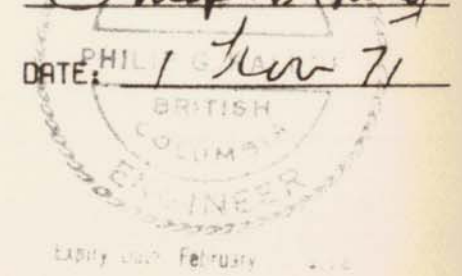

## McPHAR GEOPHYSICS

INDUCED POLARIZATION AND RESISTIVITY SURVEY

NOTE: THIS PLOT WAS PRODUCED WITH AN IBM 360/65 COMPUTER AND A CALCOMP PLOTTER

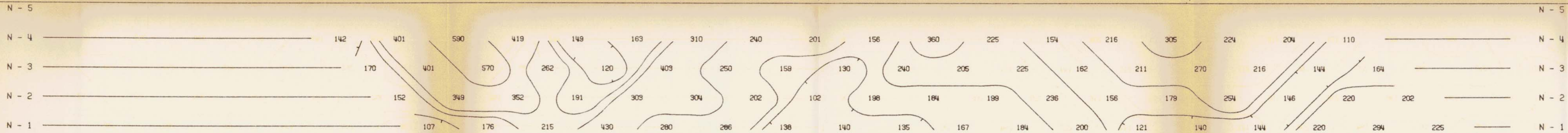

RESISTIVITY (APP.) IN OHM FEET / 2π

RESISTIVITY (APP.) IN OHM FEET / 2π

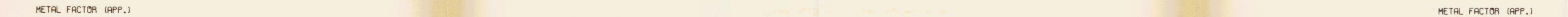

METAL FACTOR (APP.)

METAL FACTOR (APP.)

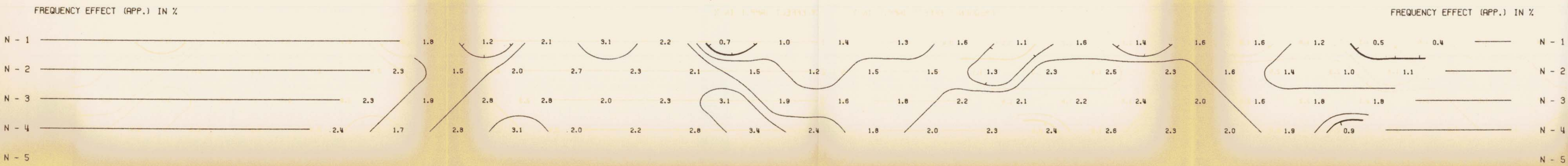

FREQUENCY EFFECT (APP.) IN %

FREQUENCY EFFECT (APP.) IN %



# NITTETSU MINING CO. LTD.

CORTINA GRID, BABINE LAKE AREA  
OMINECA M.D., B.C.

Department of  
Mines and Petroleum Resources  
ASSESSMENT REPORT  
NO. 3542 MAP #4

LINE NO. - 800W

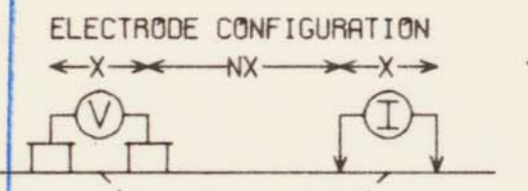

PLOTTING POINT X = 200'

SURFACE PROJECTION OF ANOMALOUS ZONES  
DEFINITE   
PROBABLE   
POSSIBLE

FREQUENCIES: 0.31-5.0 HZ DATE SURVEYED: AUG 1971

APPROVED:   
DATE:

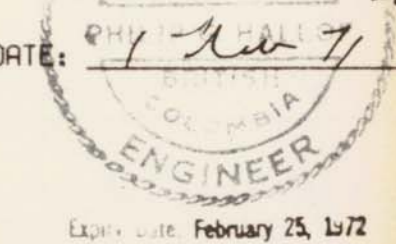

NOTE: CONTOURS AT LOGARITHMIC INTERVALS 1.-1.5-2.-3.-5.-7.5-10

## McPHAR GEOPHYSICS

INDUCED POLARIZATION AND RESISTIVITY SURVEY

NOTE: THIS PLOT WAS PRODUCED WITH AN IBM 360/65 COMPUTER AND A CALCOMP PLOTTER

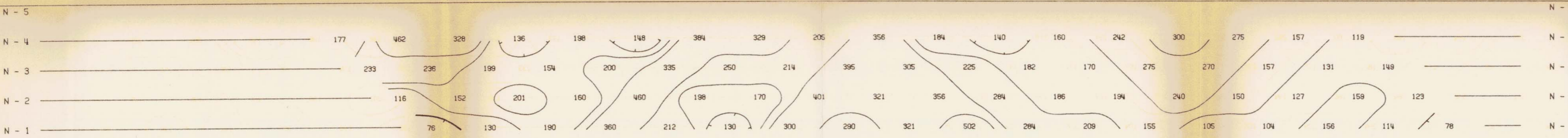

RESISTIVITY (APP.) IN OHM FEET / 2π

RESISTIVITY (APP.) IN OHM FEET / 2π

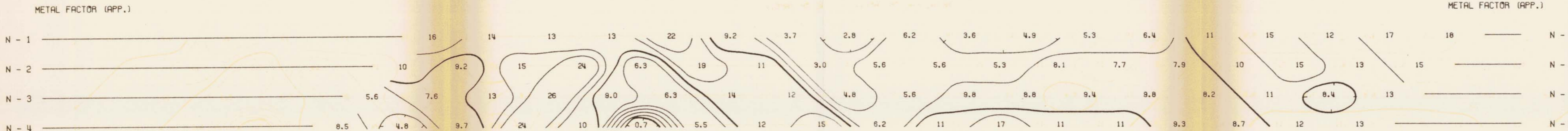

METAL FACTOR (APP.)

METAL FACTOR (APP.)

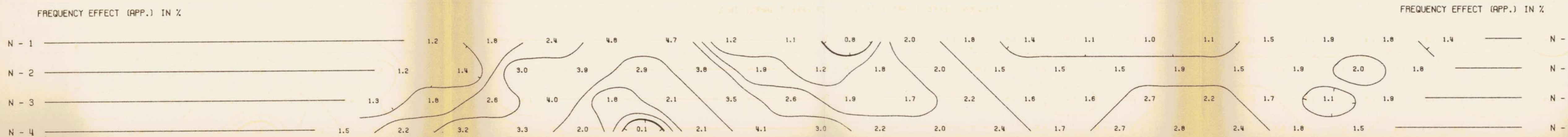

FREQUENCY EFFECT (APP.) IN %

FREQUENCY EFFECT (APP.) IN %



# NITTETSU MINING CO. LTD.

CORTINA GRID, BABINE LAKE AREA  
OMINECA M.D., B.C.

Department of  
Mines and Petroleum Resources  
ASSESSMENT REPORT  
NO. 3542 MAP #5

LINE NO. - 0

ELECTRODE CONFIGURATION  
← X → NX → X →

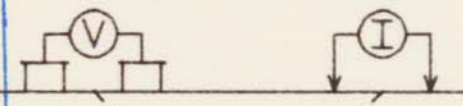

PLOTTING POINT → X X = 200'

SURFACE PROJECTION OF ANOMALOUS ZONES

DEFINITE   
PROBABLE   
POSSIBLE

FREQUENCIES: 0.31-5.0 HZ

DATE SURVEYED: AUG 1971

APPROVED:   
DATE: 1 Nov 71

NOTE: CONTOURS AT LOGARITHMIC INTERVALS 1.-1.5-2.-3.-5.-7.5-10

## McPHAR GEOPHYSICS

INDUCED POLARIZATION AND RESISTIVITY SURVEY

NOTE: THIS PLOT WAS PRODUCED WITH AN IBM 360/65 COMPUTER AND A CALCOMP PLOTTER

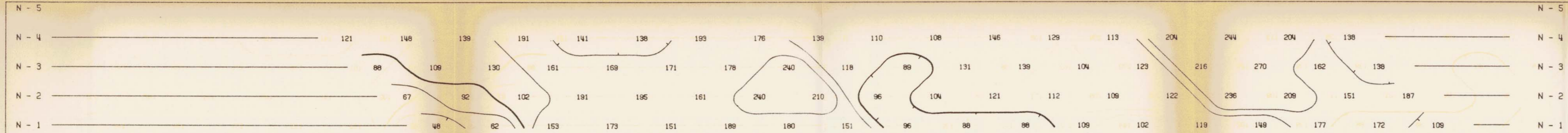

RESISTIVITY (APP.) IN OHM FEET / 2π

RESISTIVITY (APP.) IN OHM FEET / 2π

METAL FACTOR (APP.)

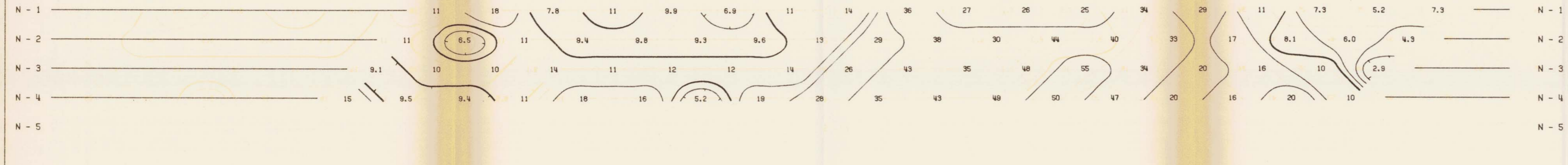

FREQUENCY EFFECT (APP.) IN %

FREQUENCY EFFECT (APP.) IN %

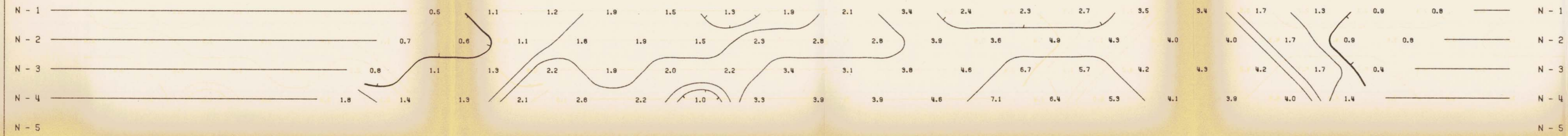



# NITTETSU MINING CO. LTD.

CORTINA GRID, BABINE LAKE AREA  
OMINECA M.D., B.C.

Department of  
Mines and Petroleum Resources  
ASSESSMENT REPORT  
NO. 3542 MAP #6

LINE NO. - 800E

ELECTRODE CONFIGURATION

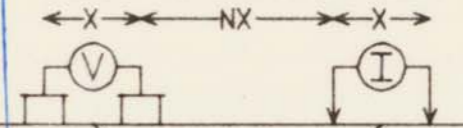

PLOTTING POINT  
X X = 200'

SURFACE PROJECTION  
OF ANOMALOUS ZONES

DEFINITE   
PROBABLE   
POSSIBLE

FREQUENCIES: 0.31-5.0 HZ

DATE SURVEYED: AUG 1971

APPROVED  
*Philip H. Helby*  
PHILIP H. HELBY  
COLUMBIA  
ENGINEER  
DATE: *Jan 71*  
Expiry Date: *1972*

NOTE: CONTOURS AT  
LOGARITHMIC INTERVALS  
1.-1.5-2.-3.-5.-7.5-10

## McPHAR GEOPHYSICS

INDUCED POLARIZATION AND RESISTIVITY SURVEY

NOTE: THIS PLOT WAS PRODUCED WITH AN IBM 360/65 COMPUTER AND A CALCOMP PLOTTER

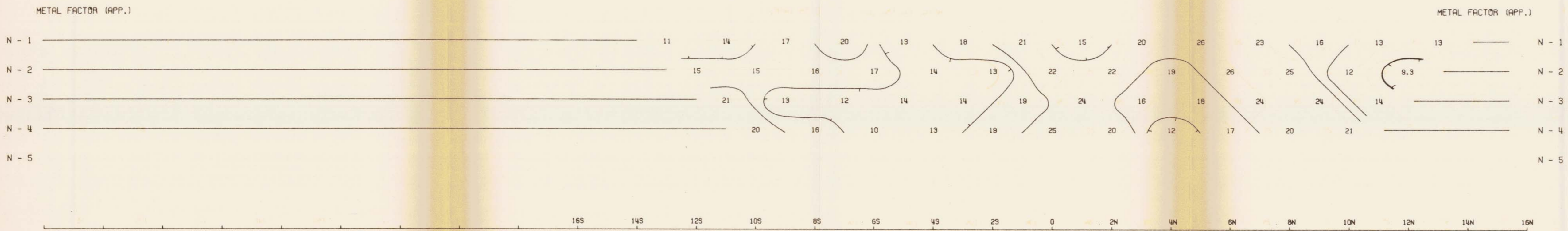
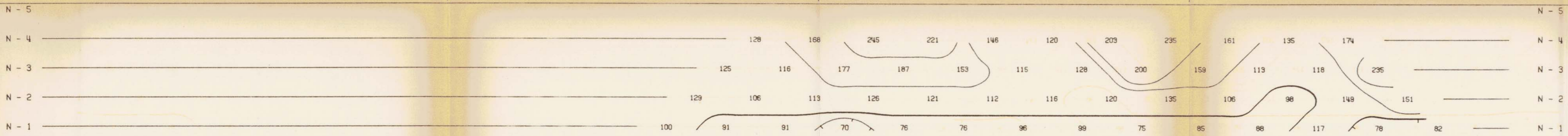







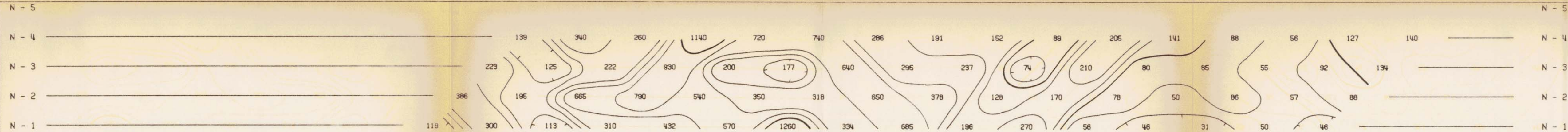

RESISTIVITY (APP.) IN OHM FEET / 2π

RESISTIVITY (APP.) IN OHM FEET / 2π

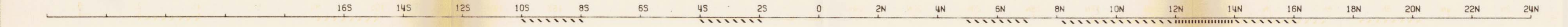

METAL FACTOR (APP.)

METAL FACTOR (APP.)

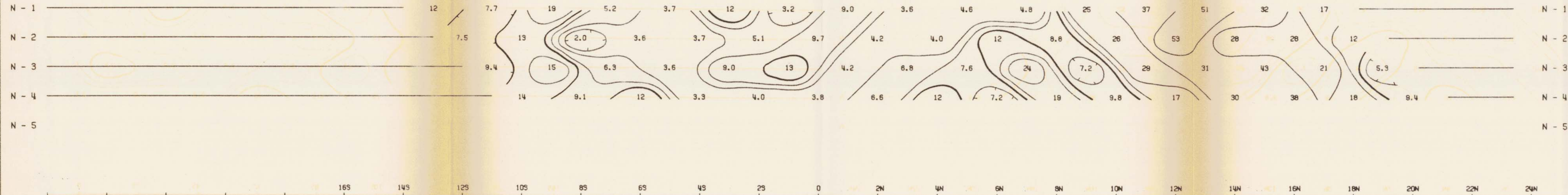

FREQUENCY EFFECT (APP.) IN %

FREQUENCY EFFECT (APP.) IN %

DWG. NO. - I.P. - 5851-7

**NITTETSU MINING CO. LTD.**

CORTINA GRID, BABINE LAKE AREA  
OMINECA M.D., B.C.

Department of  
Mines and Petroleum Resources  
ASSESSMENT REPORT  
NO. 3542 MAP #8

LINE NO. - 2400E

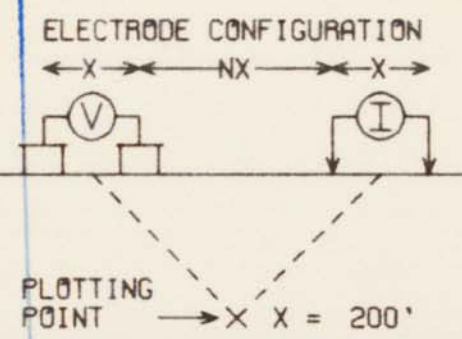

SURFACE PROJECTION OF ANOMALOUS ZONES

DEFINITE   
PROBABLE   
POSSIBLE

FREQUENCIES: 0.31-5.0 HZ

DATE SURVEYED: AUG 1971

NOTE: CONTOURS AT LOGARITHMIC INTERVALS 1.-1.5-2.-3.-5.-7.5-10

APPROVED:   
PHILIP G. HALLOF  
DATE:   
COLUMBIA  
ENGINEER  
Expiry Date: February 2, 1972

**McPHAR GEOPHYSICS**

INDUCED POLARIZATION AND RESISTIVITY SURVEY

NOTE: THIS PLOT WAS PRODUCED WITH AN IBM 360/65 COMPUTER AND A CALCOMP PLOTTER





CAVONA GROUP

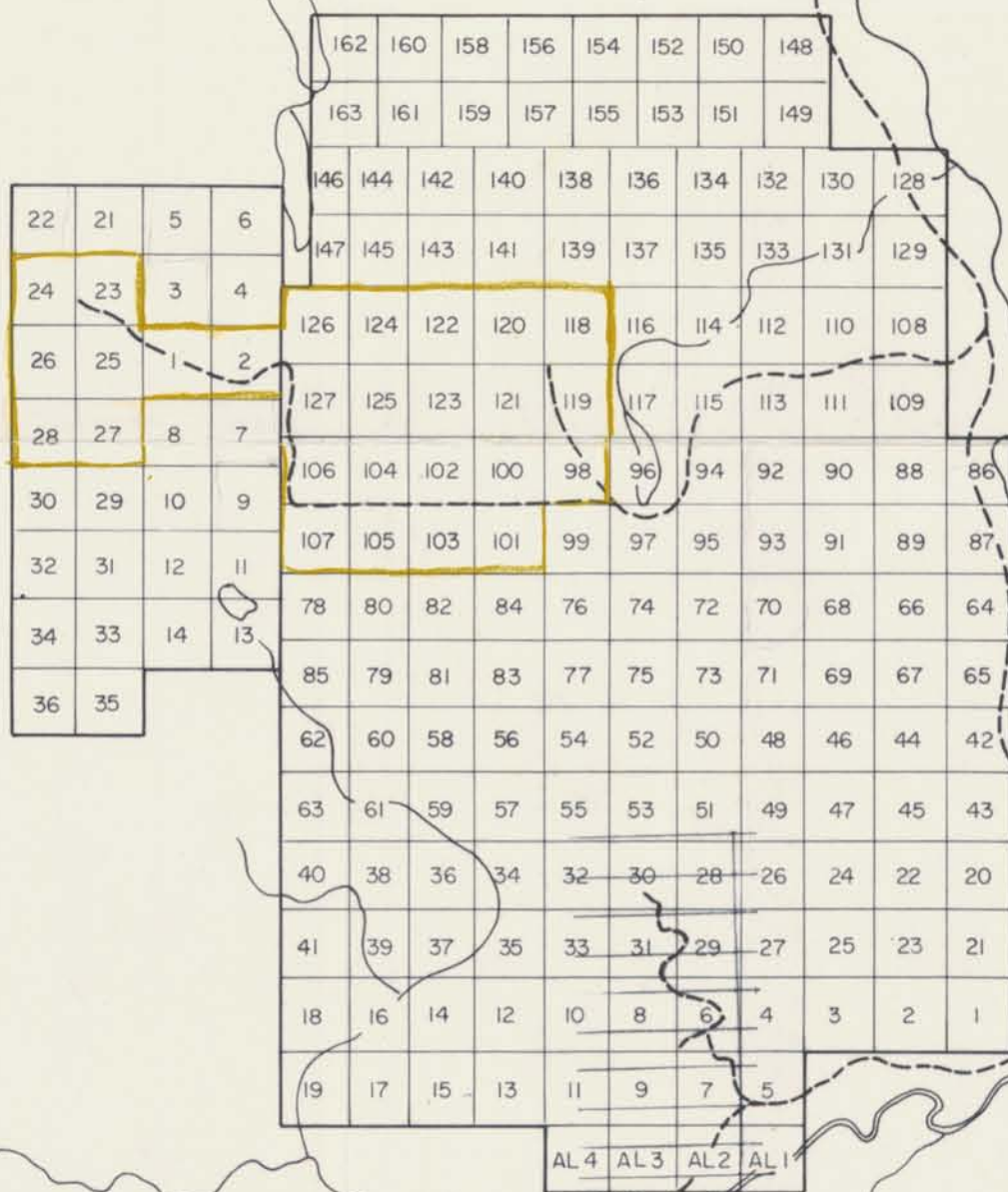

TOP GROUP

CORTINA GROUP

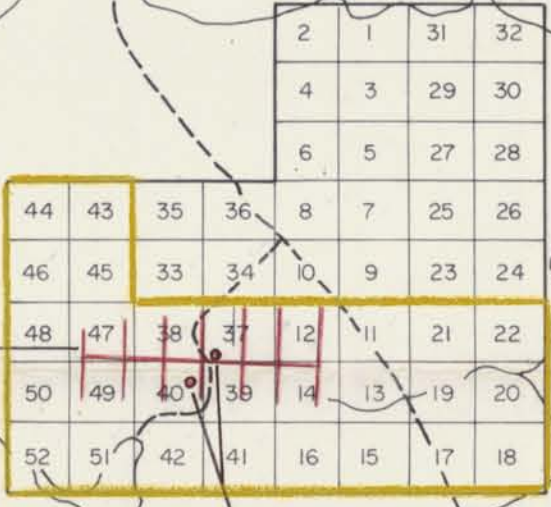

Grid

D.D. Hole

COUGAR GROUP

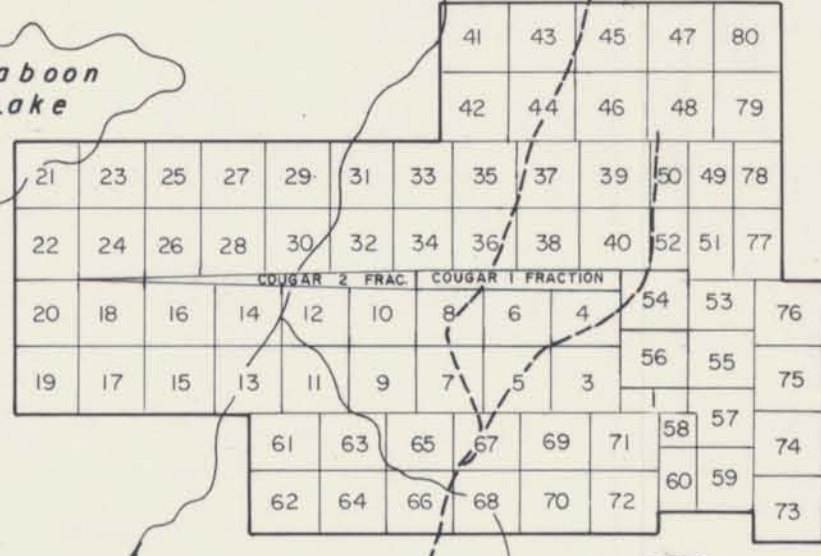

Department of  
Mines and Petroleum Resources  
ASSESSMENT REPORT  
NO. 3542 MAP #9

NITTETSU MINING CO., LTD.  
CLAIM HOLDINGS

BABINE LAKE AREA  
OMINECA MINING DIVISION

SCALE = 1 : 50,000

SEPT 30, 1971

W. G. S.



DWG. IPP - 3505

# McPHAR GEOPHYSICS

INDUCED POLARIZATION AND RESISTIVITY SURVEY

PLAN MAP

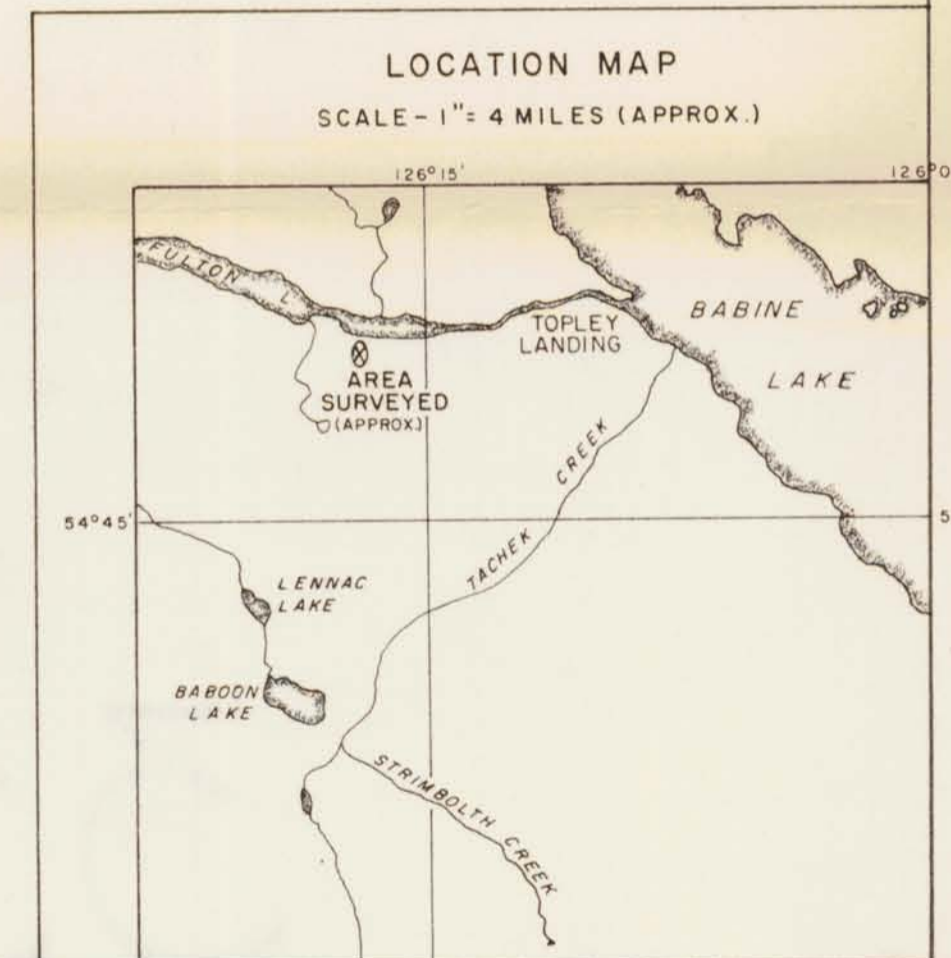

NOTE -  
 TO ACCOMPANY GEOPHYSICAL REPORT BY  
 P. G. HALLOF, P. ENG., AND M. A. GOUDIE, GEOLOGIST,  
 FOR NITTETSU MINING CO., ON THE CORTINA GRID,  
 BABINE LAKE AREA, OMINECA M. D., B. C.  
 DATED: NOVEMBER 1, 1971

SURFACE PROJECTION  
 OF ANOMALOUS ZONES

DEFINITE —————  
 PROBABLE - - - - -  
 POSSIBLE / / / / /  
 200 Ft. electrode intervals used

NITTETSU MINING CO., LTD.  
 CORTINA GRID, BABINE LAKE AREA  
 OMINECA M. D., B. C.  
 SCALE  
 ONE INCH EQUALS FOUR HUNDRED FEET

M-1

LEGEND  
 ———— OUTLINE OF ANOMALOUS  
 I. P. ZONE

Department of  
 Mines and Petroleum Resources  
 ASSESSMENT REPORT  
 NO. 3542 MAP #1

APPROVED:  
*Philip G. Hallof*  
 DATE: NOV 1 1971