

364

Department of  
Mines and Petroleum Resources  
ASSESSMENT REPORT  
NO. 3646 MAP

93L/QW  
REPORT ON THE  
INDUCED POLARIZATION  
AND RESISTIVITY SURVEY  
ON THE  
CODE FEN PROPERTY,  
OMINECA MINING DIVISION,  
BRITISH COLUMBIA  
FOR  
HELICON EXPLORATIONS LIMITED

BY

A.W. MULLAN, P.ENG.

AND

DAVID K. FOUNTAIN, P.ENG.

NAME AND LOCATION OF PROPERTY:

CODE FEN PROPERTY

OMINECA MINING DIVISION, B.C. 54° 10'N, 126° 57'W.

DATE STARTED: MARCH 21, 1972

DATE FINISHED: APRIL 12, 1972

Mining Recorder's Office  
RECORDED  
MAY 26 1972  
AT \_\_\_\_\_  
SMITHERS, B.C.

## TABLE OF CONTENTS

|                |                                     |                       |
|----------------|-------------------------------------|-----------------------|
| <u>Part A:</u> | Notes on theory and field procedure | 9 pages               |
| <u>Part B:</u> | Report                              | 11 pages              |
|                |                                     | <u>Page</u>           |
| 1.             | Introduction                        | 1                     |
| 2.             | Presentation of Results             | 3                     |
| 3.             | Discussion of Results               | 4                     |
| 4.             | Summary and Conclusions             | 6                     |
| 5.             | Assessment Details                  | 8                     |
| 6.             | Interim Statement of Cost           | 9                     |
| 7.             | Certificate - Ashton W. Mullan      | 10                    |
| 8.             | Certificate - David K. Fountain     | 11                    |
| <u>Part C:</u> | Illustrations                       | 8 pieces              |
|                | #1 Plan Map (in pocket)             | Dwg. I. P. P. 3524    |
|                | #2-8 I. P. Data Plots               | Dwgs. IP 5924-1 to -7 |

# McPHAR GEOPHYSICS

## NOTES ON THE THEORY, METHOD OF FIELD OPERATION AND PRESENTATION OF DATA FOR THE INDUCED POLARIZATION METHOD

---

Induced Polarization as a geophysical measurement refers to the blocking action or polarization of metallic or electronic conductors in a medium of ionic solution conduction.

This electro-chemical phenomenon occurs wherever electrical current is passed through an area which contains metallic minerals such as base metal sulphides. Normally, when current is passed through the ground, as in resistivity measurements, all of the conduction takes place through ions present in the water content of the rock, or soil, i. e. by ionic conduction. This is because almost all minerals have a much higher specific resistivity than ground water. The group of minerals commonly described as "metallic", however, have specific resistivities much lower than ground waters. The induced polarization effect takes place at those interfaces where the mode of conduction changes from ionic in the solutions filling the interstices of the rock to electronic in the metallic minerals present

in the rock.

The blocking action or induced polarization mentioned above, which depends upon the chemical energies necessary to allow the ions to give up or receive electrons from the metallic surface, increases with the time that a d. c. current is allowed to flow through the rock; i. e. as ions pile up against the metallic interface the resistance to current flow increases. Eventually, there is enough polarization in the form of excess ions at the interfaces, to appreciably reduce the amount of current flow through the metallic particle. This polarization takes place at each of the infinite number of solution-metal interfaces in a mineralized rock.

When the d. c. voltage used to create this d. c. current flow is cut off, the Coulomb forces between the charged ions forming the polarization cause them to return to their normal position. This movement of charge creates a small current flow which can be measured on the surface of the ground as a decaying potential difference.

From an alternate viewpoint it can be seen that if the direction of the current through the system is reversed repeatedly before the polarization occurs, the effective resistivity of the system as a whole will change as the frequency of the switching is changed. This is a consequence of the fact that the amount of current flowing through each metallic interface depends upon the length of time that current has been passing through it in one direction.

The values of the per cent frequency effect or F. E. are a measurement of the polarization in the rock mass. However, since the measurement of the degree of polarization is related to the apparent resistivity of the rock mass it is found that the metal factor values or M. F. are the most useful values in determining the amount of polarization present in the rock mass. The MF values are obtained by normalizing the F. E. values for varying resistivities.

The induced polarization measurement is perhaps the most powerful geophysical method for the direct detection of metallic sulphide mineralization, even when this mineralization is of very low concentration. The lower limit of volume per cent sulphide necessary to produce a recognizable IP anomaly will vary with the geometry and geologic environment of the source, and the method of executing the survey. However, sulphide mineralization of less than one per cent by volume has been detected by the IP method under proper geological conditions.

The greatest application of the IP method has been in the search for disseminated metallic sulphides of less than 20% by volume. However, it has also been used successfully in the search for massive sulphides in situations where, due to source geometry, depth of source, or low resistivity of surface layer, the EM method can not be successfully applied. The ability to differentiate ionic conductors, such as water filled shear zones, makes the IP method a useful tool in checking EM

anomalies which are suspected of being due to these causes.

In normal field applications the IP method does not differentiate between the economically important metallic minerals such as chalcopyrite, chalcocite, molybdenite, galena, etc., and the other metallic minerals such as pyrite. The induced polarization effect is due to the total of all electronic conducting minerals in the rock mass. Other electronic conducting materials which can produce an IP response are magnetite, pyrolusite, graphite, and some forms of hematite.

In the field procedure, measurements on the surface are made in a way that allows the effects of lateral changes in the properties of the ground to be separated from the effects of vertical changes in the properties. Current is applied to the ground at two points in distance (X) apart. The potentials are measured at two other points (X) feet apart, in line with the current electrodes is an integer number (n) times the basic distance (X).

The measurements are made along a surveyed line, with a constant distance (nX) between the nearest current and potential electrodes. In most surveys, several traverses are made with various values of (n); i. e. (n) = 1, 2, 3, 4, etc. The kind of survey required (detailed or reconnaissance) decides the number of values of (n) used.

In plotting the results, the values of the apparent resistivity, apparent per cent frequency effect, and the apparent metal factor

measured for each set of electrode positions are plotted at the intersection of grid lines, one from the center point of the current electrodes and the other from the center point of the potential electrodes. (See Figure A.) The resistivity values are plotted above the line as a mirror image of the metal factor values below. On a second line, below the metal factor values, are plotted the values of the per cent frequency effect. In some cases the values of per cent frequency effect are plotted as superscripts of the metal factor value. In this second case the frequency effect values are not contoured. The lateral displacement of a given value is determined by the location along the survey line of the center point between the current and potential electrodes. The distance of the value from the line is determined by the distance ( $nX$ ) between the current and potential electrodes when the measurement was made.

The separation between sender and receiver electrodes is only one factor which determines the depth to which the ground is being sampled in any particular measurement. The plots then, when contoured, are not section maps of the electrical properties of the ground under the survey line. The interpretation of the results from any given survey must be carried out using the combined experience gained from field results, model study results and theoretical investigations. The position of the electrodes when anomalous values are measured is important in the interpretation.

In the field procedure, the interval over which the potential differences are measured is the same as the interval over which the electrodes are moved after a series of potential readings has been made. One of the advantages of the induced polarization method is that the same equipment can be used for both detailed and reconnaissance surveys merely by changing the distance (X) over which the electrodes are moved each time. In the past, intervals have been used ranging from 25 feet to 2000 feet for (X). In each case, the decision as to the distance (X) and the values of (n) to be used is largely determined by the expected size of the mineral deposit being sought, the size of the expected anomaly and the speed with which it is desired to progress.

The diagram in Figure A demonstrates the method used in plotting the results. Each value of the apparent resistivity, apparent metal factor, and apparent per cent frequency effect is plotted and identified by the position of the four electrodes when the measurement was made. It can be seen that the values measured for the larger values of (n) are plotted farther from the line indicating that the thickness of the layer of the earth that is being tested is greater than for the smaller values of (n); i. e. the depth of the measurement is increased. When the F. E. values are plotted as superscripts to the MF values the third section of data values is not presented and the F. E. values are not contoured.

The actual data plots included with the report are prepared utilizing an IBM 360/75 Computer and a Calcomp 770/763 Incremental Plotting System. The data values are calculated, plotted, and contoured according to a programme developed by McPhar Geophysics. Certain symbols have been incorporated into the programme to explain various situations in recording the data in the field.

The IP measurement is basically obtained by measuring the difference in potential or voltage ( $\Delta V$ ) obtained at two operating frequencies. The voltage is the product of the current through the ground and the apparent resistivity of the ground. Therefore in field situations where the current is very low due to poor electrode contact, or the apparent resistivity is very low, or a combination of the two effects; the value of ( $\Delta V$ ) the change in potential will be too small to be measurable. The symbol "TL" on the data plots indicates this situation.

In some situations spurious noise, either man made or natural, will render it impossible to obtain a reading. The symbol "N" on the data plots indicates a station at which it is too noisy to record a reading. If a reading can be obtained, but for reasons of noise there is some doubt as to its accuracy, the reading is bracketed in the data plot ( ).

In certain situations negative values of Apparent Frequency Effect are recorded. This may be due to the geologic environment or spurious electrical effects. The actual negative frequency effect value recorded is indicated on the data plot, however the symbol "NEG" is

indicated for the corresponding value of Apparent Metal Factor. In contouring negative values the contour lines are indicated to the nearest positive value in the immediate vicinity of the negative value.

The symbol "NR" indicates that for some reason the operator did not attempt to record a reading although normal survey procedures would suggest that one was required. This may be due to inaccessible topography or other similar reasons. Any symbol other than those discussed above is unique to a particular situation and is described within the body of the report.

## METHOD USED IN PLOTTING DIPOLE-DIPOLE INDUCED POLARIZATION AND RESISTIVITY RESULTS

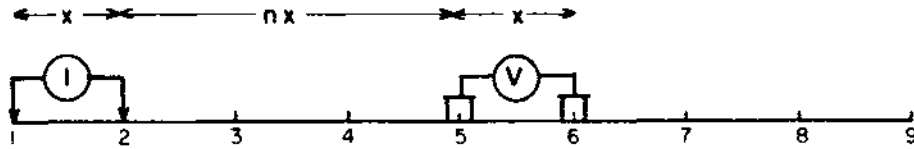

Stations on line

$x$  = Electrode spread length  
 $n$  = Electrode separation

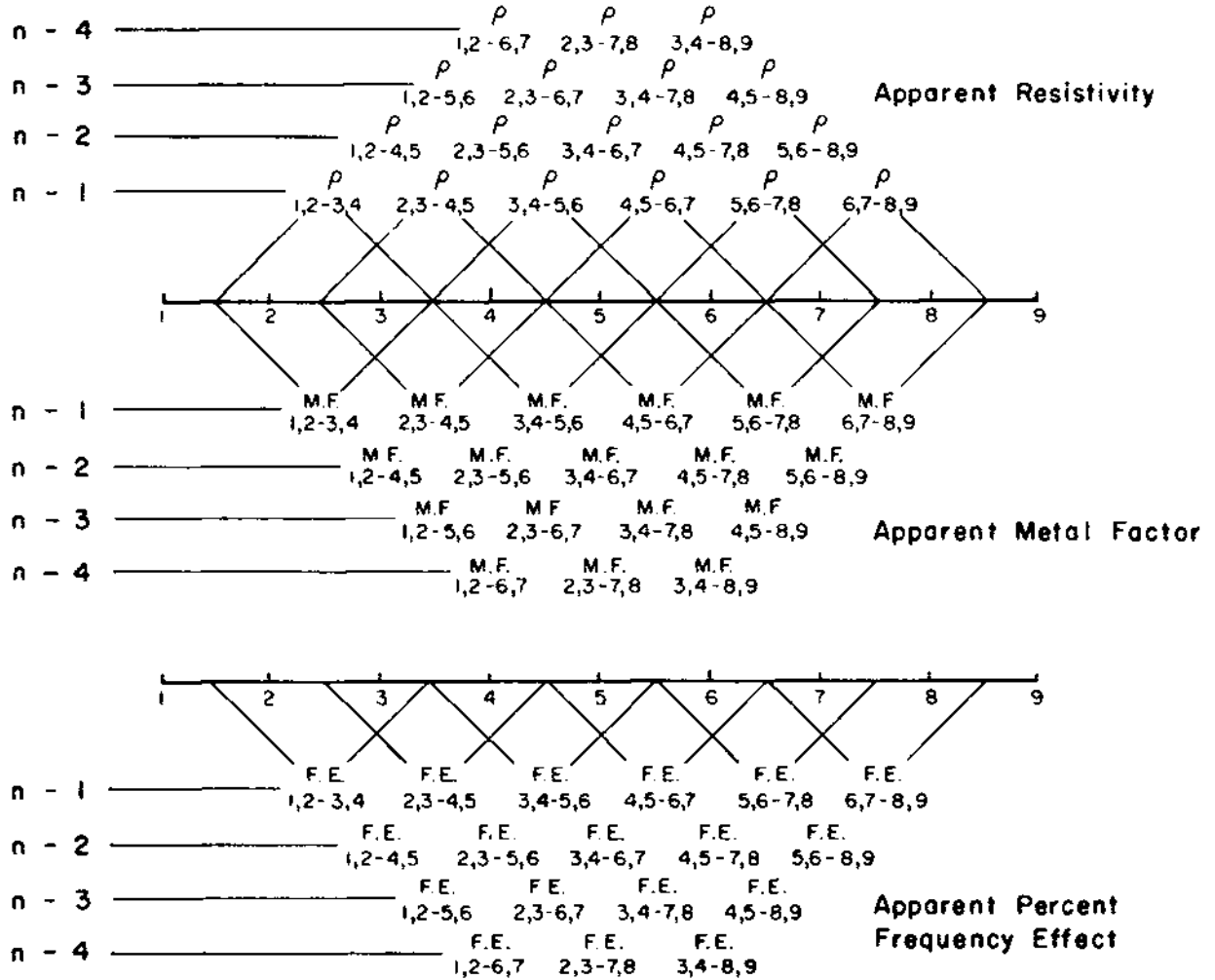

Fig. A

**McPHAR GEOPHYSICS LIMITED**

**REPORT ON THE  
INDUCED POLARIZATION  
AND RESISTIVITY SURVEY**

**ON THE  
CODE FEN PROPERTY,  
OMINECA MINING DIVISION,  
BRITISH COLUMBIA**

**FOR  
HELICON EXPLORATIONS LIMITED**

---

**1. INTRODUCTION**

During late March and early April, 1972, an Induced Polarization and Resistivity survey was carried out on a portion of the Code Fen property of Helicon Explorations Limited in the Omineca Mining Division of British Columbia. The claim group is located approximately 21 miles southwest of the town of Houston and lies immediately northwest of Nadina Mountain and south of Merice River at the headwaters of Fenton Creek. It is situated at approximately latitude  $54^{\circ} 10'$  north and longitude  $126^{\circ} 57'$  west. Access to the property is by two short roads branching south from the main Merice River road.

The geophysical survey work discussed in this report was carried out on the following claims of the Code Fen property, all of which are located in the Omineca Mining Division.

|      |   |       |
|------|---|-------|
| CODE | 3 | 30316 |
|      | 4 | 30317 |
|      | 5 | 30318 |
|      | 6 | 30319 |

|      |    |       |
|------|----|-------|
| CODE | 7  | 30320 |
|      | 8  | 30321 |
|      | 9  | 30322 |
|      | 10 | 30323 |
|      | 13 | 30326 |
|      | 14 | 30327 |
|      | 15 | 30328 |
|      | 21 | 55646 |
|      | 22 | 57203 |
|      | 24 | 57205 |
|      | 42 | 87260 |
|      | 44 | 87262 |

|     |     |       |
|-----|-----|-------|
| FEN | 1   | 87601 |
|     | 3   | 87603 |
|     | 4   | 87604 |
|     | 5   | 87605 |
|     | 7   | 87607 |
|     | 13  | 87613 |
|     | 14  | 87614 |
|     | 15  | 87615 |
|     | 208 | 94587 |
|     | 227 | 93136 |

The IP survey was carried out employing a McPhar variable frequency Induced Polarization unit utilizing the dipole - dipole electrode configuration and 100 and 200 foot dipoles. The frequencies employed throughout the survey were 0.3 Hz and 5.0 Hz.

Bedrock exposure is scarce in the area covered by the present IP survey. However, geologic mapping suggests that much of the area covered by the IP survey is underlain by altered acid volcanics. A mineralized zone has been located in the vicinity of the intersection of Line 20800W and Line 20000N (Base Line), consisting of fine-grained pyrite and specks of sphalerite disseminated throughout a wide area of bleached and highly altered acid volcanic rocks. Previous work carried out on the entire claim group has consisted of IP and magnetic surveys, as well as geochemical sampling, geological mapping and trenching. The purpose of the present IP survey work is to further evaluate the immediate area of

this zone of mineralization.

## 2. PRESENTATION OF RESULTS

The Induced Polarisation and Resistivity results are shown on the following data plots in the manner described in the notes preceding this report.

| <u>Line</u>   | <u>Electrode Intervals</u> | <u>Dwg. No.</u> |
|---------------|----------------------------|-----------------|
| 20000N (East) | 200 feet                   | IP 5924-1       |
| 20000N (West) | 200 feet                   | IP 5924-2       |
| 20800W        | 100 feet                   | IP 5924-3       |
| 22000W        | 100 feet                   | IP 5924-4       |
| 24000W        | 100 feet                   | IP 5924-5       |
| 24200W        | 100 feet                   | IP 5924-6       |
| 26200W        | 100 feet                   | IP 5924-7       |

Also enclosed with this report is Dwg. I.P.P. 3524, a plan map of the Code Fen Grid at a scale of 1" = 400'. The definite, probable and possible Induced Polarisation anomalies are indicated by bars, in the manner shown on the legend, on this plan map as well as on the data plots. These bars represent the surface projection of the anomalous zones as interpreted from the location of the transmitter and receiver electrodes when the anomalous values were measured.

Since the Induced Polarization measurement is essentially an averaging process, as are all potential methods, it is frequently difficult to exactly pinpoint the source of an anomaly. Certainly, no anomaly can be located with more accuracy than the electrode interval length; i.e., when using 100' electrode intervals, the position of a narrow sulphide body can only be determined to lie between two stations 100' apart. In order to definitely locate, and fully evaluate, a narrow, shallow source, it is necessary to use shorter electrode intervals. In order to locate sources

at some depth, larger electrode intervals must be used, with a corresponding increase in the uncertainties of location. Therefore, while the centre of the indicated anomaly probably corresponds fairly well with source, the length of the indicated anomaly along the line should not be taken to represent the exact edges of the anomalous material.

The location of survey lines relative to claim boundaries, the names and relative position of the claims and the geologic data indicated on Dwg. I.P.P. 3524 and discussed in the report, are based upon information supplied by Helicon Explorations Limited.

### 3. DISCUSSION OF RESULTS

The IP data discussed in this report consist of one long east - west line surveyed with 200 foot dipoles and five shorter north - south lines surveyed with 100 foot dipoles. The north - south lines are widely spaced except for Line 24000W and Line 24200W. The survey results indicate a long narrow east - west zone of anomalous response, such as would be expected from disseminated metallic mineralization. This anomalous zone includes the known area of mineralization and it is assumed that the location of the present IP survey lines has been based upon information obtained from the previous geophysical work carried out.

Compilation of relative changes in the value of background resistivity may assist in outlining areas of geologic interest on the property, especially since the mineralization is apparently associated with highly altered acid volcanic rocks, which would have lower values of resistivity. There is not sufficient data available from the present survey to do a meaningful compilation. However, if the previous IP survey data were available, it may prove of assistance. Since the claim group is locally covered with deep glacial drift, extreme care would be required in using the resistivity data to differentiate between changes in bedrock resistivity and changes in depth of glacial cover.

Line 20000N

This line forms the axis of the anomalous zone. Moderate to good anomalous IP response extends from 185W to 228W with the higher IP response occurring between 185W and 192W and between 195W and 212W. Weaker response extends to 254W.

Line 20800W

Correlating with the results on the east - west line, a distinct anomaly is indicated between 199+50N and 202N with probable and possible anomalies extending south and north to 191+50N and 206N respectively.

Line 22000W

The results on this line correlate with both the east - west line and the previous north - south line. A definite anomaly is indicated from 196N to 200+50N with probable and possible anomalies extending to the north to 206N and to the south to 193+50N.

Line 24000W

The anomalous zone continues westward to this line, although narrower and less distinct than on the lines to the east. A distinct, narrow and deep anomaly is centred between 196N and 197+50N.

Line 24200W

A broad possible anomaly, correlating with the main anomalous zone extends from 197N to 204N on this line. The weaker responses on Line 24200W and Line 24000W correlate with the results obtained on the long east - west line, which indicated a decrease in anomalous IP response to the west of 228W.

Line 26200W

Weak possible anomalies are indicated between 193N and

195N and centred at 203N. The main anomalous zone does not appear to extend as far west as this line.

#### 4. SUMMARY AND CONCLUSIONS

The results of the present IP survey have outlined a long narrow east - west zone of anomalous response, such as would be expected from disseminated metallic mineralization. The magnitude of the IP response decreases to the west along the axis of the zone. This would suggest metallic mineralization grading from moderately disseminated to weakly disseminated from east to west.

The known mineralization in the anomalous zone consists of pyrite and sphalerite. Since sphalerite is non-conductive, the IP response would appear to be due entirely to the pyrite content, unless other metallic conductive mineralization is present. It would be necessary to determine the relationship between the economic mineralization, such as sphalerite and the pyrite, in order to properly assess the relative significance of moderate and weak anomalous IP response.

The approximate location of a series of thirteen diamond drill holes has been supplied by Helicon Explorations Limited and these are indicated on Dwg. I.P.P. 3524. Some of these holes have been completed although the results are not available.

##### Line 20800W

DDH #1, DDH #2 and DDH #4 should have evaluated the source of the IP anomaly on this line.

##### Line 22000W

DDH #3 should have intersected the definite IP anomaly indicated on this line.

##### Line 24000W

A series of eight diamond drill holes are located along this

line. DDH #5 and DDH #6 are located north of the anomalous IP zone and would assist in evaluating the source of the IP response. DDH #8 and DDH #9 and DDH #12 would investigate the main anomaly, although DDH #12 would have to be either stepped back to the south or drilled near vertical to investigate the deep anomaly centred between 196N and 197+50N. DDH #7 is on the north flank of the anomalous zone and would evaluate the above background IP response here. DDH #10 and DDH #11 would investigate the weak possible anomaly to the south of the main zone.

Line 26200W

DDH #13 is located off the end of the main zone and is located between the two weak possible anomalies indicated on this line. Unless this hole location is based on other than geophysical information, it could be eliminated from the program.

-----  
Recommendations for further drilling would be dependent upon a review of the results of the above series of holes, as well as any previous drilling. The IP results from the present survey would suggest that additional IP surveying on north - south lines in the section from 212W to 186W would be warranted.

McPHAR GEOPHYSICS LIMITED

*A. W. Mullan*

A. W. Mullan, P. Eng.  
Geologist.

*David K. Fountain*  
David K. Fountain  
Geophysicist.

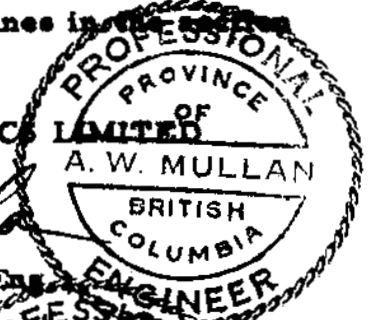

Dated: May 8, 1972.

Expiry Date: April 25, 1973

ASSESSMENT DETAILS

|                                       |                               |
|---------------------------------------|-------------------------------|
| PROPERTY: Code-Fen Property           | MINING DIVISION: Omineca      |
| SPONSOR: Helicon Explorations Limited | PROVINCE: British Columbia    |
| TYPE OF SURVEY: Induced Polarization  |                               |
| OPERATING MAN DAYS: 56                | DATE STARTED: March 21, 1972  |
| EQUIVALENT 8 HR. MAN DAYS: 84         | DATE FINISHED: April 12, 1972 |
| CONSULTING MAN DAYS: 4                | NUMBER OF STATIONS: 220       |
| DRAUGHTING MAN DAYS: 6                | NUMBER OF READINGS: 2772      |
| TOTAL MAN DAYS: 94                    | MILES OF LINE SURVEYED: 5.66  |

CONSULTANTS:

Ashton W. Mullan, 1440 Sandhurst Place, West Vancouver, B. C.  
David K. Fountain, 62 Patina Drive, Willowdale 428, Ontario.

FIELD TECHNICIANS:

J. Parker, Box 340, Choiceland, Saskatchewan.  
Plus Extra Labour:  
Wesley West Garde, Box 102, Houston, B. C.  
Keith Hoftner, Box 176, Houston, B. C.  
Darcy Lund, Box 51, Houston, B. C.  
Larry Wright, 750 Connaught Ave. Nanaimo, B. C.  
Harvey Scott, Box 284, Houston, B. C.

DRAUGHTSMEN:

G. Hines, 60 Oak Avenue, Richvale, Ontario.  
N. Lade, 299 Jasper Avenue, Oshawa, Ontario.  
V. Young, 703 Cortez Avenue, Bay Ridges, Ontario.

McPHAR GEOPHYSICS LIMITED

*A. W. Mullan*  
A. W. Mullan, P. Eng. A. W. MULLAN

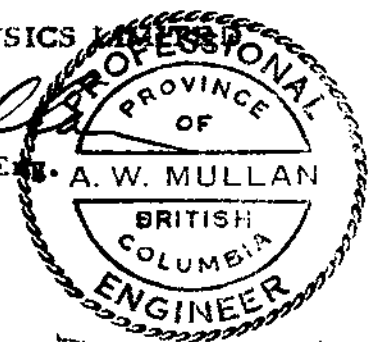

Dated: May 8, 1972

INTERIM STATEMENT OF COST

Helicon Explorations Limited,  
IP Survey, Houston, B.C.

Crew (1 man) - J. Parker

|                             |                |            |
|-----------------------------|----------------|------------|
| 14 days Operating           | @ \$240.00 day | \$3,360.00 |
| 3 days Travel )             |                |            |
| 1 days Bad Weather ) 7 days | @ \$ 75.00 day | 525.00     |
| 2 days Standby )            |                |            |

Expenses

|                         |               |                   |
|-------------------------|---------------|-------------------|
| Vehicle expense         | 388.40        |                   |
| Meals and Accommodation | 110.00        |                   |
| Freight and Brokerage   | 6.00          |                   |
| Telephone and Telegraph | 19.00         |                   |
| Supplies                | 86.05         |                   |
|                         | <u>609.45</u> |                   |
| + 10%                   | <u>60.95</u>  | 670.40            |
| Extra Labour            | 775.00        |                   |
| + 20%                   | <u>155.00</u> | 930.00            |
|                         |               | <u>\$5,485.40</u> |

\* Note This statement reflects at least 90% of the total cost; there may be a few minor charges not yet received by us and hence not included in the foregoing.

McPHAR GEOPHYSICAL  
*A. W. Mullan*  
A. W. Mullan. P. Eng. W. MULLAN

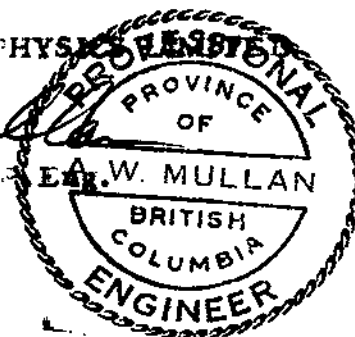

Dated: May 8, 1972

CERTIFICATE

I, Ashton W. Mullan, of the City of Vancouver, in the Province of British Columbia, hereby certify:

1. That I am a geologist and a fellow of the Geological Association of Canada with a business address at Suite 811, 837 West Hastings Street, Vancouver, B.C.
2. That I am registered as a member of the Association of Professional Engineers of the Provinces of Ontario and British Columbia.
3. That I hold a B.Sc. degree from McGill University.
4. That I have been practising my profession as a geologist for about twenty years.
5. I have no direct or indirect interest, nor do I expect to receive any interest directly or indirectly, in the property or securities of Helicon Explorations Limited or any affiliate.
6. The statements made in this report are based on a study of published geological literature and unpublished private reports.
7. Permission is granted to use in whole or in part for assessment and qualification requirements but not for advertising purposes.

Dated at Toronto

this 8th day of May, 1972

  
A. W. Mullan, E.S.



CERTIFICATE

I, David Kirkman Fountain, of the City of Toronto, Province of Ontario, do certify that:

1. I am a geophysicist residing at 62 Patina Drive, Willowdale 428, Ontario.

2. I am a graduate of the University of Toronto with a Bachelor of Applied Science Degree in Engineering Physics (Geophysics).

3. I am a member of the Society of Exploration Geophysicists, the European Association of Exploration Geophysicists and the Canadian Institute of Mining and Metallurgy.

4. I am a Registered Professional Engineer in the Provinces of British Columbia, Manitoba and Ontario, a Registered Professional Geophysicist in the Province of Alberta and a Registered Professional Geologist in the State of California, and have been practising my profession for eleven years.

5. The statements made in this report are based on a study of published geological literature and unpublished private reports.

6. Permission is granted to use in whole or in part for assessment and qualification requirements but not for advertising purposes.

Dated at Toronto

This 8th day of May, 1972

  
David Kirkman Fountain, B.Sc., P. Eng.



Expiry Date: April 25, 1973

McPHAR GEOPHYSICS  
 INDUCED POLARIZATION AND RESISTIVITY SURVEY  
 PLAN MAP



NOTE: TO ACCOMPANY GEOPHYSICAL REPORT FOR  
 HELICON EXPLORATION LTD., CODE-FEN PROPERTY,  
 OMINECA M.D., BC. BY D.K.FOUNTAIN (PENG.)  
 AND A.W.MALLAN (PENG.)  
 DATED: MAY 8, 1972



SURFACE PROJECTION  
 OF ANOMALOUS ZONES  
 DEFINITE (—————)  
 PROBABLE (-----)  
 POSSIBLE (.....)  
 Number of the end of electrode  
 indicating spread used

ANOMALOUS IN ZONE

HELICON EXPLORATIONS LTD.  
 CODE-FEN PROPERTY  
 OMINECA M.D., BC.  
 SCALE  
 ONE INCH EQUALS FOUR HUNDRED FEET

3646 M-1

Department of  
 Mines and Petroleum Resources  
 ASSESSMENT REPORT  
 NO. 3646 MAP #1

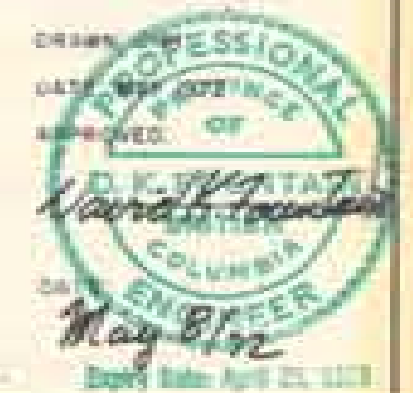

# HELICON EXPLORATIONS LTD.

CODE-FEN PROPERTY, OMECECA M.D., B.C.

LINE NO. - 20000N (EAST PART)

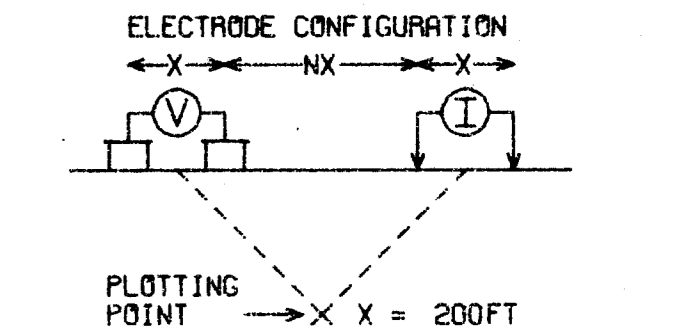

SURFACE PROJECTION OF ANOMALOUS ZONES  
 DEFINITE   
 PROBABLE   
 POSSIBLE

FREQUENCIES: 0.31-5.0 HZ

DATE SURVEYED: 05/19/72

APPROVED:

DATE:

NOTE: CONTOURS AT LOGARITHMIC INTERVALS 1.-1.5-2.-3.-5.-7.5-10

EXPIRY DATE: April 25, 1973

## McPHAR GEOPHYSICS

INDUCED POLARIZATION AND RESISTIVITY SURVEY

NOTE: THIS PLOT WAS PRODUCED BY McPHAR COMPUTER DIVISION

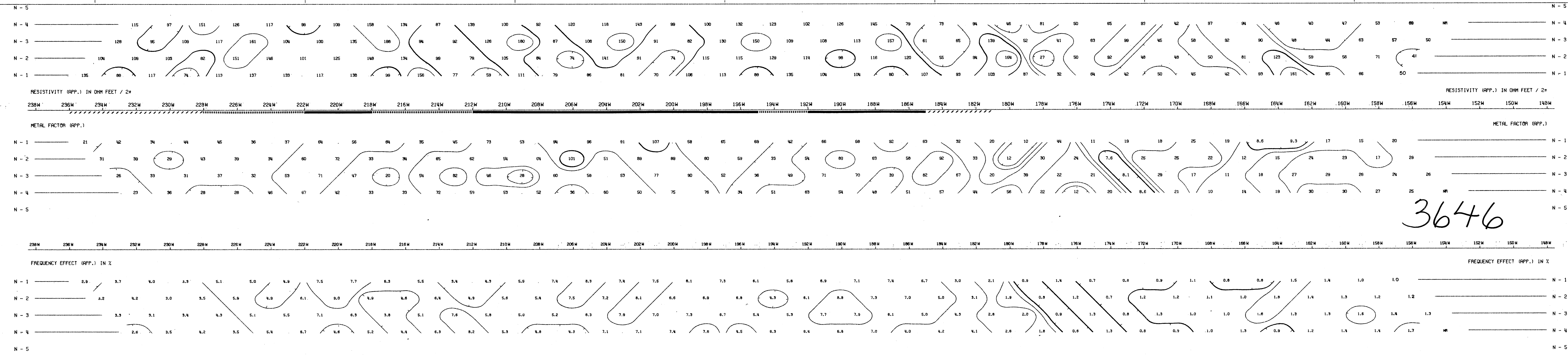

# HELICON EXPLORATIONS LTD.

CODE-FEN PROPERTY, OMINICA M.D., B.C.

LINE NO. - 20000N (WEST PART)

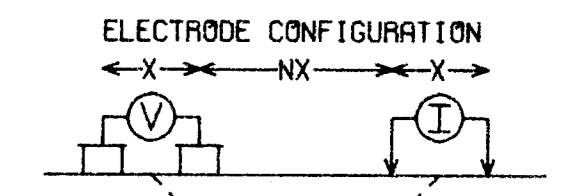

PLOTTING POINT X = 200 FT

SURFACE PROJECTION OF ANOMALOUS ZONES  
 DEFINITE   
 PROBABLE   
 POSSIBLE

FREQUENCIES: 0.31-5.0 HZ

DATE SURVEYED: 1972

APPROVED BY:   
 PROVINCE OF BRITISH COLUMBIA   
 REGISTERED PROFESSIONAL ENGINEER   
 DATE:   
 Expiry Date: April 25, 1973

NOTE: CONTOURS AT LOGARITHMIC INTERVALS 1.-1.5-2.-3.-5.-7.5-10

## McPHAR GEOPHYSICS

INDUCED POLARIZATION AND RESISTIVITY SURVEY

NOTE: THIS PLOT WAS PRODUCED BY McPHAR COMPUTER DIVISION

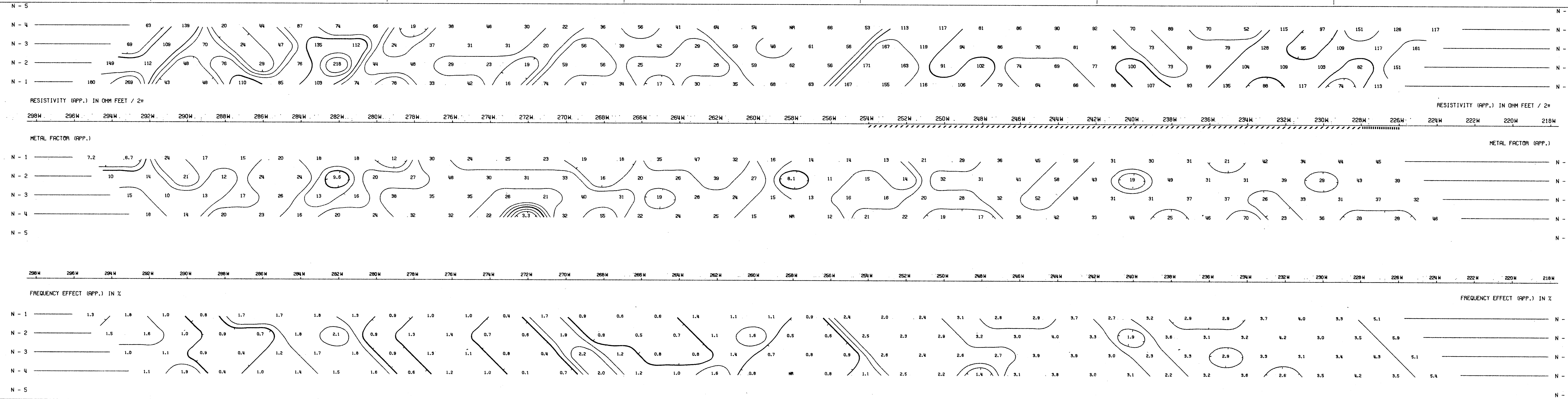

# HELICON EXPLORATIONS LTD.

CODE-FEN PROPERTY, OMINICA M.O., B.C.

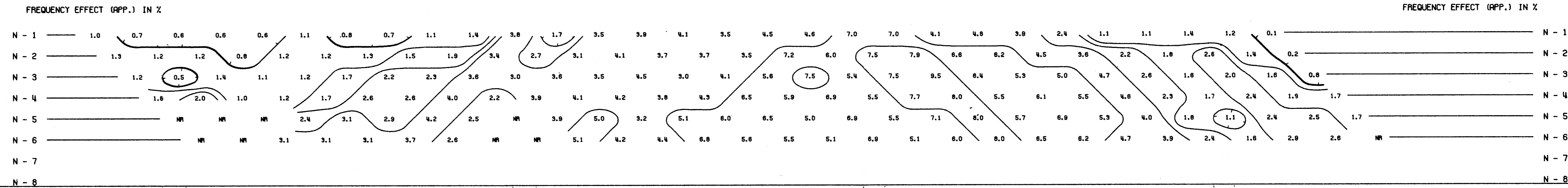
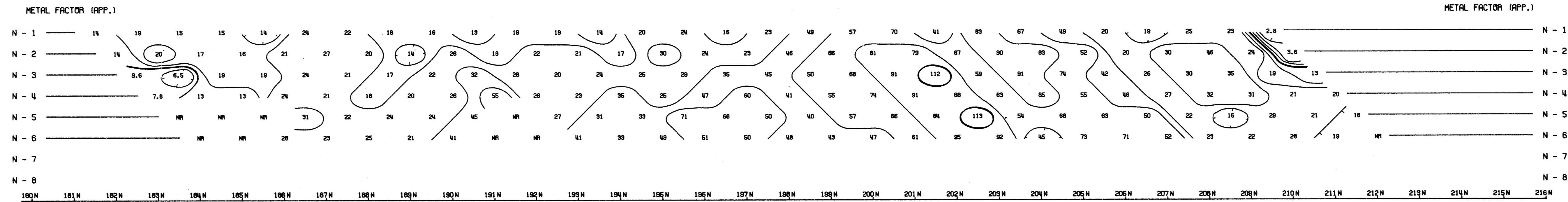
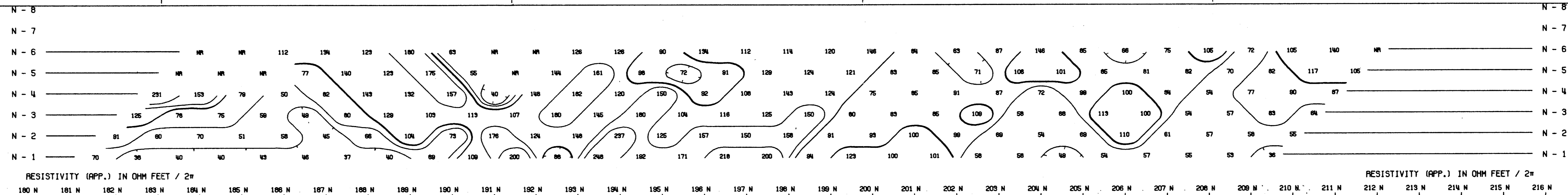

LINE NO. - 20800W

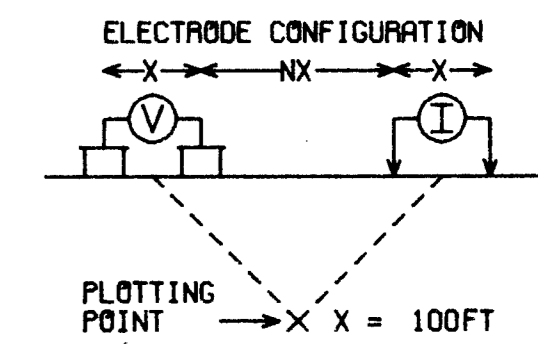

SURFACE PROJECTION OF ANOMALOUS ZONES

DEFINITE

PROBABLE

POSSIBLE

FREQUENCIES: 0.31-5.0 HZ

DATE SURVEY: MAR 1972

NOTE: CONTOURS AT LOGARITHMIC INTERVALS 1.-1.5-2.-3.-5.-7.5-10

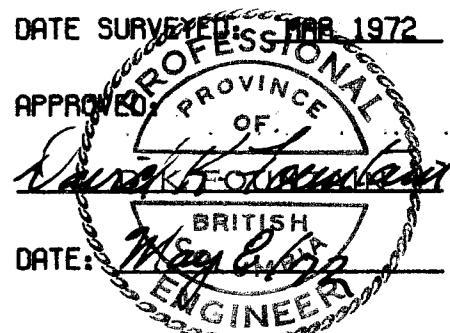

## McPHAR GEOPHYSICS

INDUCED POLARIZATION AND RESISTIVITY SURVEY

NOTE: THIS PLOT WAS PRODUCED BY McPHAR COMPUTER DIVISION

# HELICON EXPLORATIONS LTD.

CODE-FEN PROPERTY, Omineca M.D., B.C.

LINE NO. - 22000H

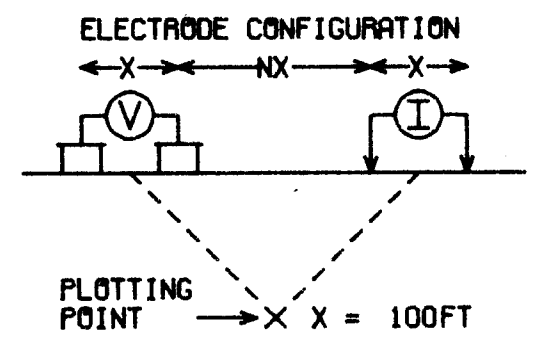

SURFACE PROJECTION OF ANOMALOUS ZONES

DEFINITE

PROBABLE

POSSIBLE

FREQUENCIES: 0.31-5.0 HZ

DATE SURVEYED: 1972

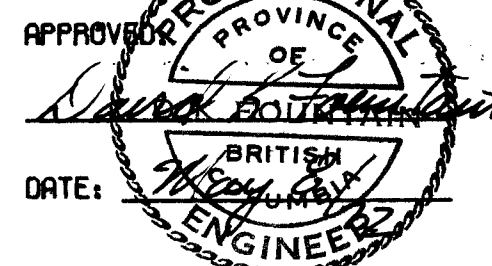

Expiry Date: April 25, 1973

NOTE: CONTOURS AT LOGARITHMIC INTERVALS  
 1.-1.5-2.-3.-5.-7.5-10

## McPHAR GEOPHYSICS

INDUCED POLARIZATION AND RESISTIVITY SURVEY

NOTE: THIS PLOT WAS PRODUCED BY McPHAR COMPUTER DIVISION

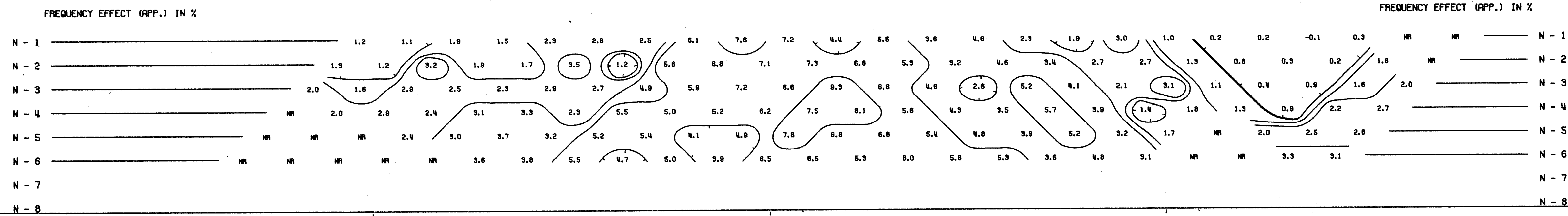
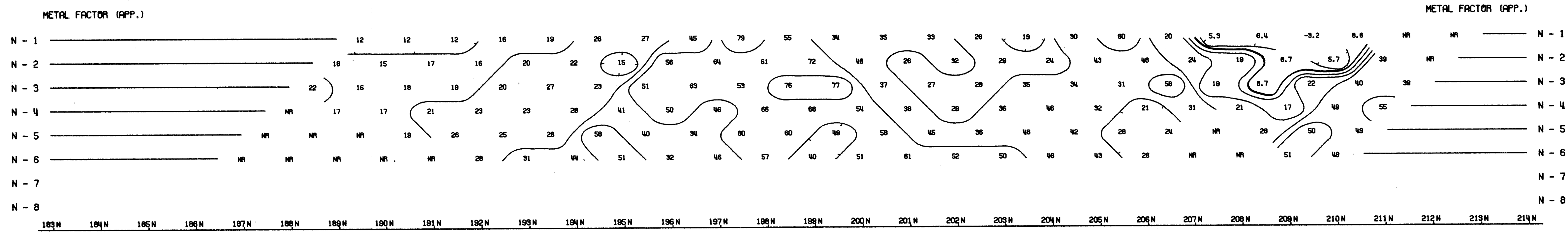
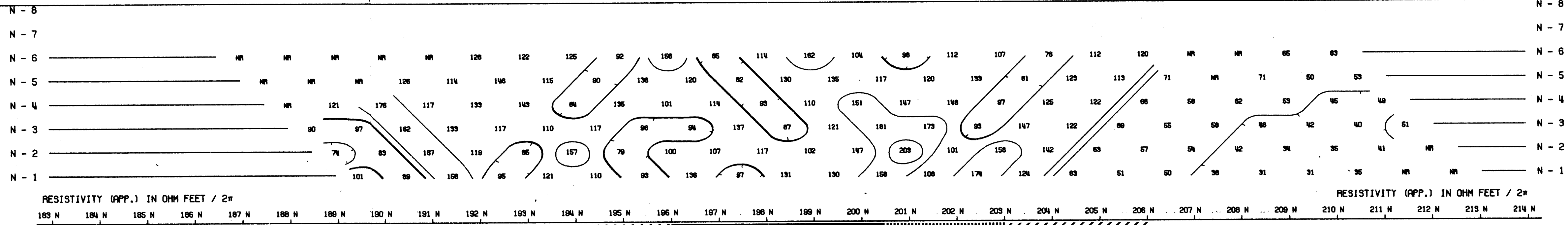

# HELICON EXPLORATIONS LTD.

CODE-FEN PROPERTY, OMINACA M.D., B.C.

LINE NO. - 24000W

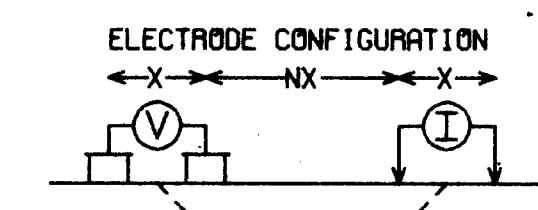

PLOTTING POINT X = 100FT

SURFACE PROJECTION OF ANOMALOUS ZONES

DEFINITE **—————**  
 PROBABLE **—————**  
 POSSIBLE **—————**

FREQUENCIES: 0.31-5.0 HZ

DATE SURVEYED: APR 1972

APPROVED: *[Signature]*  
 PROFESSIONAL ENGINEER  
 OF THE PROVINCE OF BRITISH COLUMBIA  
 DATE: *[Signature]*  
 Expiry Date: April 25, 1973

NOTE: CONTOURS AT LOGARITHMIC INTERVALS 1.-1.5-2.-3.-5.-7.5-10

## McPHAR GEOPHYSICS

INDUCED POLARIZATION AND RESISTIVITY SURVEY

NOTE: THIS PLOT WAS PRODUCED BY McPHAR COMPUTER DIVISION

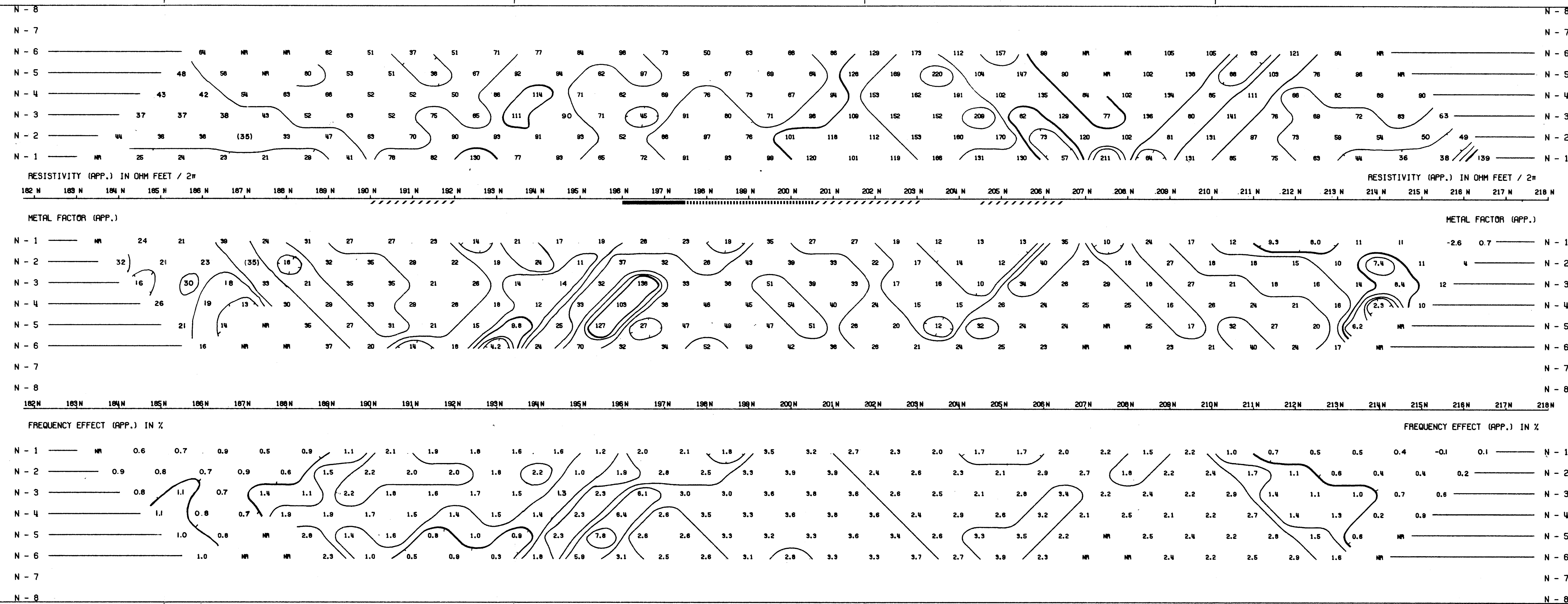

# HELICON EXPLORATIONS LTD.

CODE-FEN PROPERTY, OMINACA M.D., B.C.

LINE NO.- 24200W

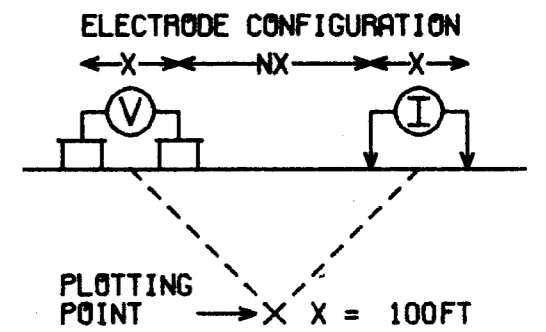

SURFACE PROJECTION OF ANOMALOUS ZONES  
 DEFINITE   
 PROBABLE   
 POSSIBLE

FREQUENCIES: 0.31-5.0 HZ

DATE SURVEYED: 1972

APPROVED:

NOTE: CONTOURS AT LOGARITHMIC INTERVALS  
 1.-1.5-2.-3.-5.-7.5-10

DATE:

Expiry Date: April 25, 1973

## McPHAR GEOPHYSICS

INDUCED POLARIZATION AND RESISTIVITY SURVEY

NOTE: THIS PLOT WAS PRODUCED BY McPHAR COMPUTER DIVISION

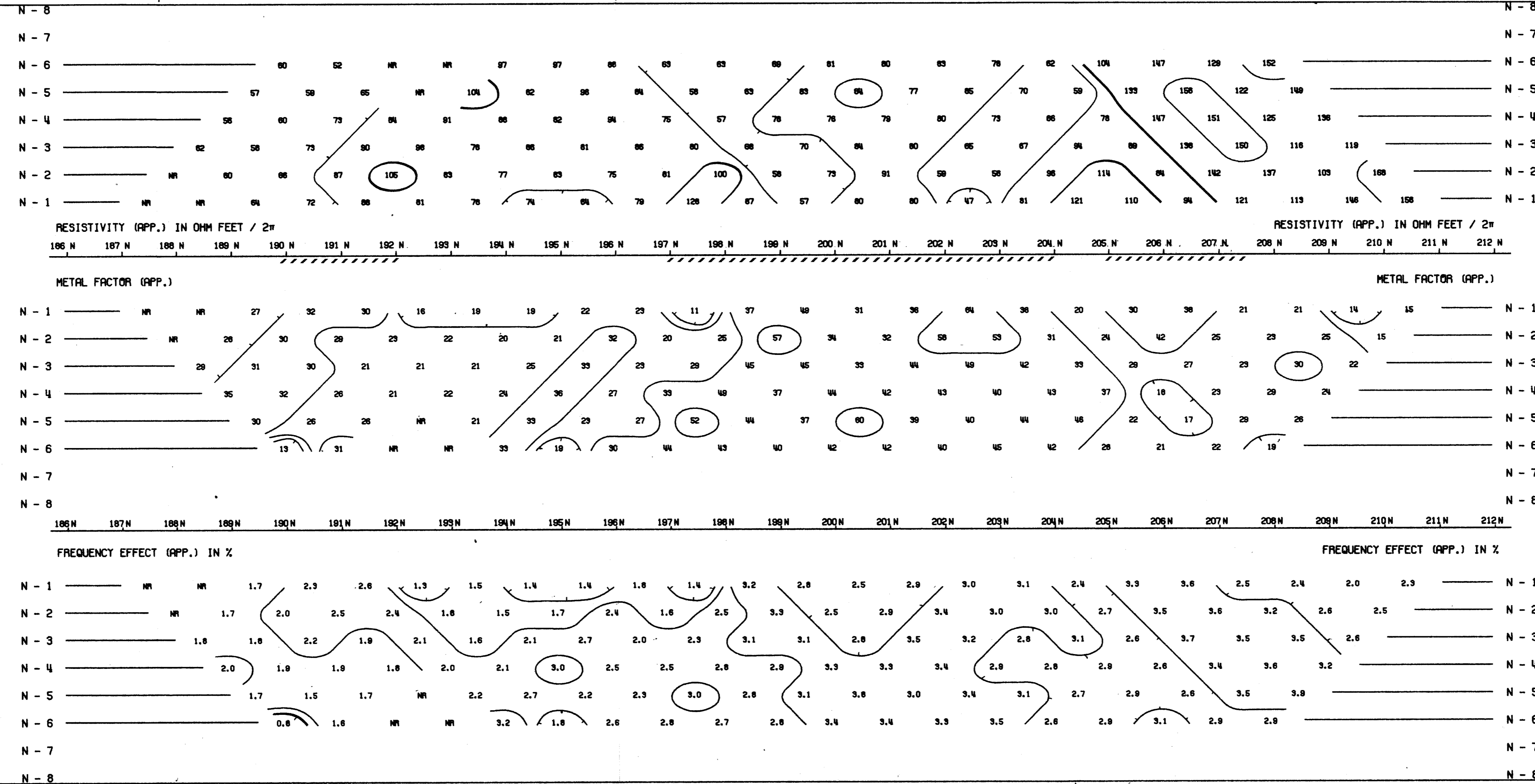

# HELICON EXPLORATIONS LTD.

CODE-FEN PROPERTY, OMECECA M.D., B.C.

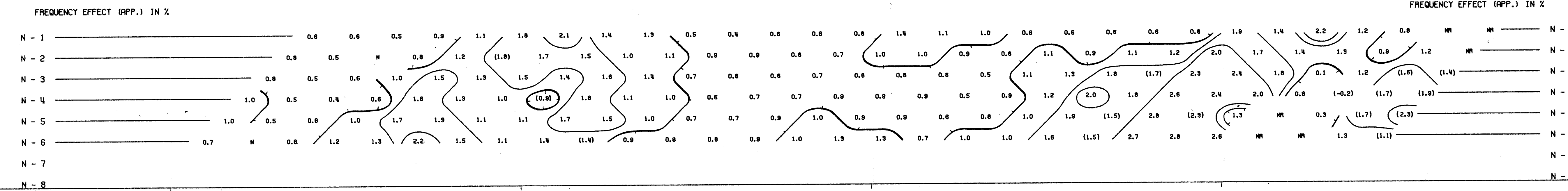
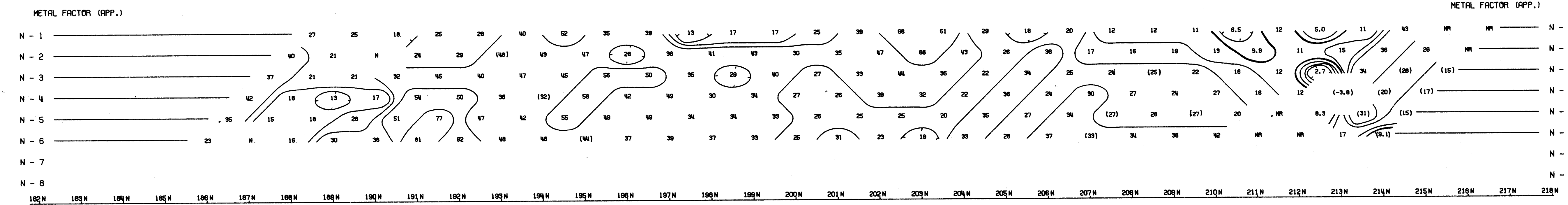
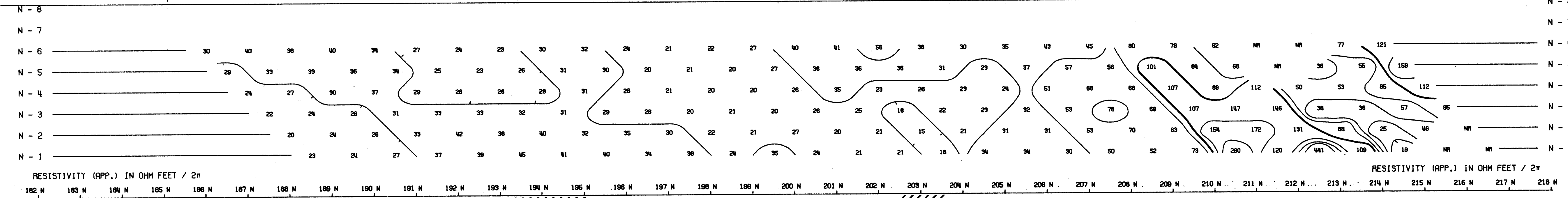

LINE NO. - 26200W

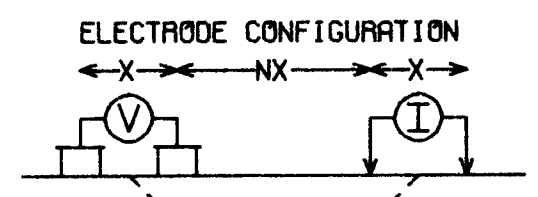

PLOTTING POINT X = 100FT

SURFACE PROJECTION OF ANOMALOUS ZONES

DEFINITE

PROBABLE

POSSIBLE

FREQUENCIES: 0.31-5.0 HZ

DATE SURVEYED: 1972

APPROVED:

PROFESSIONAL ENGINEER OF BRITISH COLUMBIA

DATE:

NOTE: CONTOURS AT LOGARITHMIC INTERVALS 1.-1.5-2.-3.-5.-7.5-10

Expiry Date: April 25, 1973

## McPHAR GEOPHYSICS

INDUCED POLARIZATION AND RESISTIVITY SURVEY

NOTE: THIS PLOT WAS PRODUCED BY McPHAR COMPUTER DIVISION