

REPORT ON AN INDUCED POLARIZATION SURVEY
ON PINE AND FIR GROUPS OF CLAIMS
LAC LE JEUNE AREA

KAMLOOPS MINING DIVISION, BRITISH COLUMBIA
ON BEHALF OF
CANADIAN JOHNS-MANVILLE COMPANY, LIMITED

BY

Philip Robertshaw, M.Sc., Geophysicist
and

Jan Klein, M.Sc., P.Eng., Geophysicist

Toronto, Ontario

October 1971

3892

COVERING: PINE CLAIMS #1 - 110
FIR CLAIMS #1 - 42
HILL CLAIMS #1 - 7 Fr.

LOCATED: 1. $50^{\circ}30'N$ $120^{\circ}29'W$
2. N.T.S. Map 921, East Half - Nicola
3. Lac Le Jeune Lake area, 15 miles south of Kam-
loops, Kamloops Mining Division, British
Columbia

C.J-M PROJECT: 410

WORK PERIOD : May 10 - June 15, 1971

REPORT DATE : March 1, 1972

SUBMITTED BY:

H.K. CONN, P.ENG.

Canadian Johns-Manville Company, Limited
Asbestos, Quebec

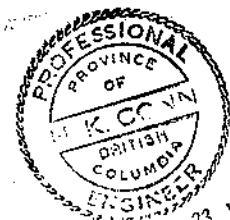
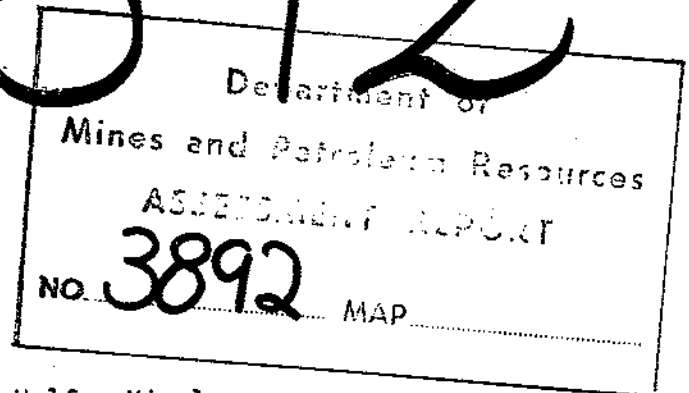
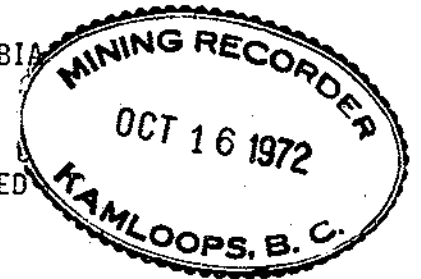

Jan 23, 1973

TABLE OF CONTENTS

SUMMARY

GENERAL INTRODUCTION

INTRODUCTION

PRESENTATION OF DATA

DISCUSSION OF RESULTS

APPENDICES:

APPENDIX I : INVOICES - SEIGEL ASSOCIATES LIMITED

APPENDIX II : STATEMENTS OF QUALIFICATIONS:

J.S. Bortnick

P. Robertshaw

J. Klein

H.K. Conn

APPENDIX III : INDUCED POLARIZATION METHOD

<u>MAPS:</u>	<u>SCALE</u>
#1 FIGURE 1: LOCATION PLAN	
#2 FIGURE 2: SURVEY LINE LOCATION PLAN	1" = 1,000' ✓
#3 PLATE 1: INDUCED POLARIZATION SURVEY L AND R ROAD GRID	1" = 200' ✓
#4 PLATE 2: INDUCED POLARIZATION SURVEY L AND R ROAD GRID	1" = 200' ✓
#5 PLATE 3: INDUCED POLARIZATION SURVEY LAC LE JEUNE GRID	1" = 200' ✓
#6 PLATE 4: INDUCED POLARIZATION SURVEY L AND R ROAD GRID	1" = 200' ✓
#7 PLATE 5: INDUCED POLARIZATION SURVEY GRID II AND III	1" = 200' ✓

SUMMARY:

Approximately eight (8) line miles of induced polarization survey have been run on the C.J-M property in the Lac Le Jeune area.

This survey has indicated distinct sources of increased chargeability response overlying the Nicola Group greenstone in the L & R Road Grid.

GENERAL INTRODUCTION

During the period May 10 to June 15, 1971 an induced polarization survey was carried out under the direction of Mr. J.S. Bortnick of Seigel Associates Limited on the Lac Le Jeune property of Canadian Johns-Manville Company, Limited.

The surveys were performed with a Scintrex Mark VII time domain (pulse type) induced polarization unit. This equipment consists of a Newmont type remotely triggered receiver and a 2.5 kW transmitter operating with a current-on-off time of two seconds. This system measures the apparent resistivity of the ground in ohmmeters and two parameters of the decay voltage during the current-off period. The chargeability, M , measured in milliseconds is the normalized integral of the transient voltage between 0.45 seconds and 1.1 seconds after current cut-off. The 0.45 seconds delay time allows most electromagnetic induction transients, switching transients and interline coupling effects to disappear before measurements are made. The area over the transient curve, taking as an upper reference the voltage at 0.45 seconds after current cut-off, can also be measured. This measurement is made during the period 0.45 seconds to 1.75 seconds after current cut-off and is expressed as the quantity, L . Like M , L is measured directly in units

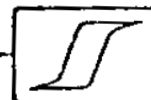

of milliseconds by the receiver. A number of consecutive integrations (usually 10) of both L and M are taken and the average values used so as to reduce telluric noise effects and other interference.

For further details on the induced polarization technique and equipment, see the attached copies of recent articles by Dr. H.O. Seigel, entitled "Induced Polarization Method", and "Some Comparative Geophysical Case Histories of Base Metal Discoveries".

In general, very little geological information has been available to the writers. The present report has therefore been mostly confined to a discussion of the I. P. results themselves, without, in most cases, attempting an interpretation in terms of lithological characteristics.

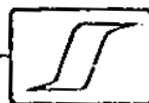

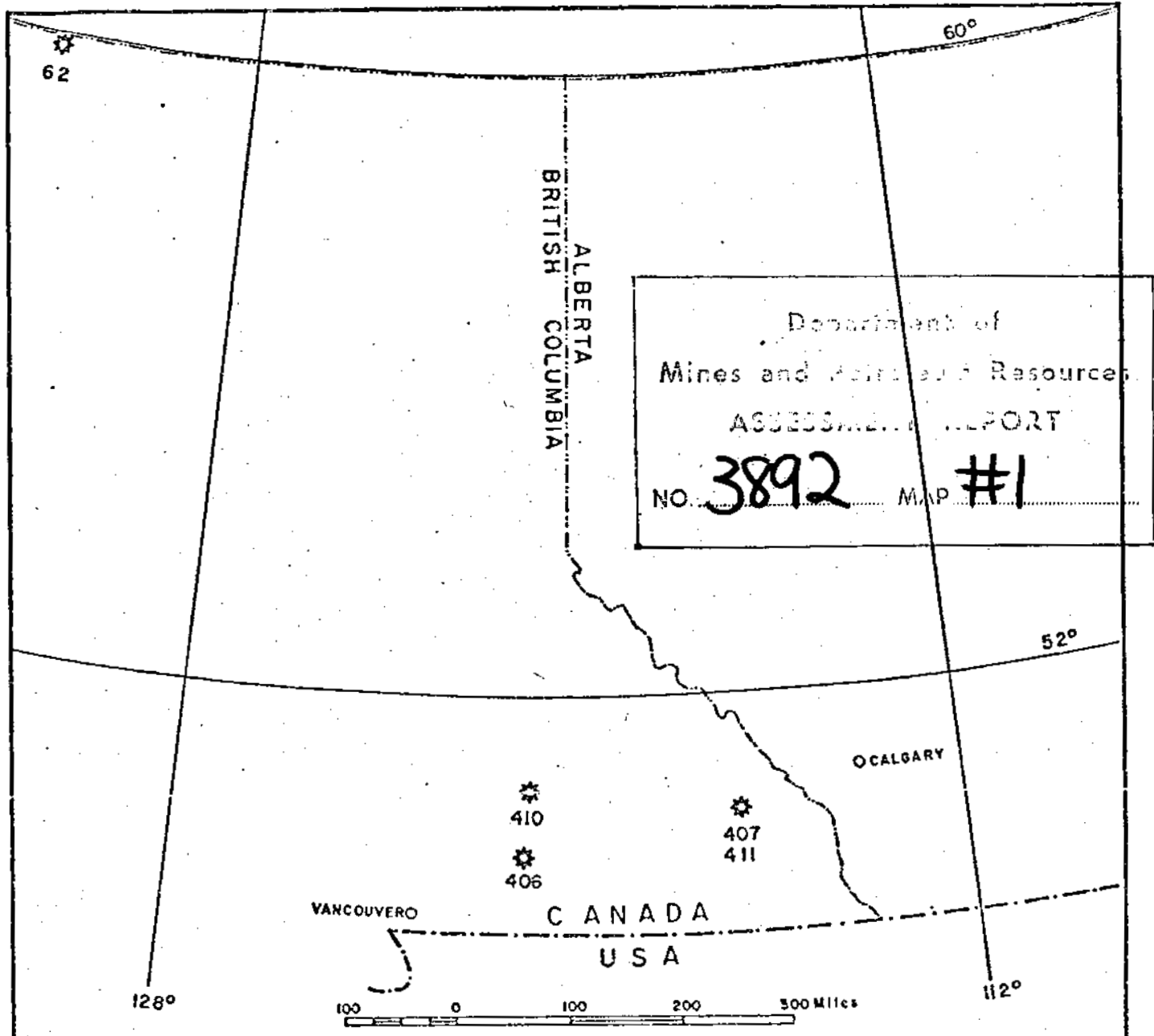

FIGURE 1

LOCATION MAP

CANADIAN JOHNS - MANVILLE Co. LIMITED

B.C. PROJECTS

INDUCED POLARIZATION SURVEY

SCALE : 1" = 140 MILES

C. J. M. PROJECT 410
Lac LeJeune

INTRODUCTION

During the period May 10th to June 15th, 1971, an induced polarization survey was executed in the Lac LeJeune area of B. C., under the direction of Mr. J. S. Bortnick of Seigel Associates Limited, on behalf of Canadian Johns-Manville Co., Limited.

Approximately 8 line miles of survey were completed during this program, most of which utilized multiple spacing dipole-dipole arrays, with $a = 200'$ or $400'$, and $n = 1, 2, 3, 4$.

PRESENTATION OF DATA

The induced polarization results obtained during the present program of the L and R Road Grid, the Lac LeJeune Grid, and Grids II and III are presented on Plates 1 to 5. The dipole-dipole array results, where 2 or 4 electrode configurations were used, are presented in pseudosection form, the chargeability and resistivity values being contoured separately for each line. The 3-array results are shown in profile form. The scales used for all the I. P. results from Project 410 are summarized in Table 1.

DISCUSSION OF RESULTS

Lines 4W, 0 and 4E (L and R Road Grid)

Plates 1 and 2 contain the results obtained over lines 4W, 0 and 4E

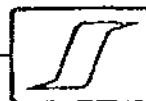

TABLE 1

	Array	Electrode Spacing	Presentation	Chargeability Contour Interval	Resistivity Contour Interval
<u>Plate 1</u> Lines 4W, 0, 4E L&R Road Grid Line 4E Line 4E	D/D	a = 400'	Pseudosection	1 and 2	20 ohm-meters
	D/D	a = 200'	Pseudosection	1 and 2	20 ohm-meters
	3	500', 1000'	Profiles		
<u>Plate 2</u> Lines 4W, 0, 4E	D/D	a = 400'	contour plans at different n-levels	1 millisecond	
<u>Plate 3</u> Lines 7+50E, 15E, 22+50E, 30E and 37+50E	3	a = 400'	Profiles		
<u>Plate 4</u> Line 22+50N Line N48°E	D/D	a = 200'	Pseudosection	1 and 2	20 ohm-meters
	D/D	a = 200'	Pseudosection	1 and 2	20 ohm-meters
<u>Plate 5</u> Lines 30E, 33+75E, 33+50E, Grids II and III	D/D	a = 200'	Pseudosection	1 and 2	20 ohm-meters

Chargeability profile scale throughout; 1":10 milliseconds, Datum @ 0

Horizontal scale throughout; 1" = 200'

Resistivity profile scale throughout; 1.33" = a factor of 10, Datum @ 10 ohm-meters

(L and R Road Grid).

The chargeability pseudosection, Plate 1, for line 4W (Dipole-dipole array, $a = 400'$, $n = 1, 2, 3, 4$) indicates the presence of two distinct sources of increased I.P. response. The greatest anomaly from the $n = 1$ coverage occurs at station 20+00S with an amplitude of 23.4 milliseconds, the background chargeability level being in the range 6 to 12 milliseconds in this area. Anomalies possibly arising from the same source appear on the $n = 2, 3$ and 4 coverage of the same line, with a peak amplitude of 28.8 milliseconds at station 8+00S for the $n = 4$ coverage. The nature of the source of this series of anomalies could be a steeply dipping body of metallic mineralization rising to within 200 feet of the ground surface, located between 20+00S and 10+00S on line 4W. The 400' electrode spacings employed here do not allow the source location to be determined with greater accuracy.

Another series of anomalies, further to the north on line 4W, is probably caused by another body of metallic mineralization located between 1+00S and 3+00N. A peak response of 18.9 milliseconds, at 2+00S, line 4W, is attributable to this source. The mineralized body in this case probably comes to within 100 to 200 feet of the surface. The $n = 4$ coverage of this zone has a peak of 29.1 milliseconds plotted at station 12+00N, suggesting, as for the previous anomaly, a considerable depth extent. Neither of these anomalies is associated with a clear-cut resistivity expression.

The strong chargeability patterns of the line 4W pseudosection cannot be traced convincingly on line 0, although a measurement of 21 milliseconds, plotted at station 4+00N on line 0, for the $n = 4$ coverage, may be caused by



mineralization at a greater depth (500' to 800').

The line 4E chargeability pseudosection for the $a = 400'$ coverage (Plate 1) contains a peak response of 19.5 milliseconds, with $n = 2$, plotted at station 4+00S. The contour pattern in this case may be interpreted in terms of metallic mineralization located between stations 2+00S and 5+00S, line 4E. The resistivity contours over the same zone again do not show an associated depression, indicating that the source is probably not electrically massive mineralization.

Additional coverage of line 4E using a dipole-dipole array with $a = 200'$ and $n = 1$ and 2 (Plate 1), and also with a 3-array configuration using spacings of 500' and 1000' (Plate 1), confirm the presence of the source of the I. P. response described above.

The results as shown on Plate 1 suggest a strike along the grid from station 4E-10N to 4W-8S. This is however not supported by the contour plans shown on Plate 2. It is therefore difficult to obtain a good three dimensional location of the source(s), as already mentioned above.

Some localized highs were shown as well, e. g. line 4E, 16+00S, $n = 3$; and line 0, 12+00S, $n = 2$; but in general these are consistent with the response pattern expected from the sources already described.

Lines 7+50E, 15+00E, 22+50E, 30+00E and 37+50E

Plate 3 contains the 3-array profile coverage ($a = 400$ feet) of lines 7+50E, 15+00E, 22+50E, 30+00E and 37+50E, Lac LeJeune Grid, within an area bounded by stations 58+00S and 94+00S. With the exception of line 22+50E the background chargeability values in this area lie in the range 5 to

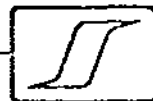

7.5 milliseconds. Line 22+50E has a background level of 7 to 9 milliseconds. No anomalous chargeability responses occur outside these ranges in the present coverage of this area. The resistivity values range from 200-800 ohmmeters and change only gradually along the profiles.

Line 22+50N (L and R Road Grid)

The line 22+50N coverage (L and R Road Grid), between stations 2+00W and 26+00E, using a dipole-dipole array with $a = 400'$, $n = 1, 2, 3$ and 4 , is shown on Plate 4. The chargeability pseudosection indicates the presence of a broad zone of I. P. response located between stations 6+00E and 12+00E. A resistivity depression of similar dimensions is associated with this feature. The highest chargeability value over this zone is 36 milliseconds, plotted at station 2+00E for the $n = 4$ electrode configuration, indicating a considerable depth extent for the source. It seems likely that the source extends to within 100' to 200' of the ground surface.

Line N48°E

The chargeability pseudosection for line N48°E (Plate 4) shows little deviation from a background level in the range 4 to 6 milliseconds. The low amplitude chargeability anomalies superimposed on this (e.g. a peak value of 7.8 milliseconds at station 38+00N for $n = 2$) coincide, in general, with high resistivity zones. These are probably due to overburden thinning, possibly outcrops, so a slightly increased chargeability reading here can be attributed to the diminished masking effect of the low I. P. response overburden.

It is suggested that a gradual change occurs in rock type along the profile. However, geological data is not available to support this impression.



Lines 30+00E, 33+75E and 37+50E (Grids II and III)

The survey results on Grids II and III (lines 30+00E, 33+75E and 37+50E) are presented on Plate 5.

The chargeability on line 30+00E reveals background levels of 4 to 7 milliseconds increasing with depth to as high as 10 milliseconds ($n = 4$). A narrow, steeply dipping source of more chargeable material is indicated near station 72+00N.

A peak value of 11.1 milliseconds occurs for the $n = 4$ coverage at station 58+00N on this line. This value coincides with a resistivity high. This coincidence is shown along most of the line.

The line 33+75E profiles do not reveal any anomalous responses.

Line 37+50E reveals a weak but clear resistivity depression between stations 41+00N and 43+00N, coinciding with a slight chargeability increase, possibly reflecting a fault zone (clay filling). Background levels on the latter two lines are the same as those for line 30+00E.

Respectfully submitted,



Philip Robertshaw, M. Sc.,
Geophysicist.

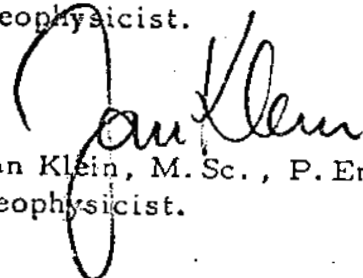

Jan Klein, M. Sc., P. Eng.,
Geophysicist.

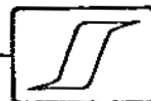

SEIGEL ASSOCIATES LIMITED
 GEOPHYSICAL CONSULTANTS & CONTRACTORS
 A DIVISION OF SCINTREX LIMITED

October 25th. 1971.

Invoice 71097.

Canadian Johns Manville Co. Ltd,
 P.O. Box 1500,
 Asbestos, Quebec.

Re: Geophysical Survey
 Kamloops Area, British Columbia
 Contract 9382

RECEIVED
 EX. 111
 292710
 405-4-21
 405-4-21
 411-4-21
 411-4-21

A. Operator, August 10th. to September 11th.

Travel and Standby Days
 August, 15-21, 27-31,
 September, 1, 2, 7, 10 & 11,

17 days @ \$90.00 \$1,530.00

Work Days
 August, 10-14, 22-26,
 September, 3-6, 8 & 9,

16/24 X \$3,000.00 2,000.00

\$3,530.00

B. Expenses, May 10th. to September 11th.

Hotel	65.05
Meals	139.00
Local Trans.	38.70
Telephone,	
Postage, Misc.	<u>53.00</u>
	295.75
Plus 10%	<u>29.58</u>

325.33

C. Extra Sepias & Prints 28.24
 Plus 10% 2.82

31.06

\$3,886.39

23 CA 2-3-72

SEIGEL ASSOCIATES LIMITED
GEOPHYSICAL CONSULTANTS & CONTRACTORS
A DIVISION OF SCINTREX LIMITED

October 25th. 1971.

Project Breakdown of

Invoice 71097.

C. Madian Johns Manville,
P.O. Box 1500,
Asbestos, Quebec.

Re: Geophysical Survey
Kamloops Area, British Columbia
Contract 9382.

Project Breakdown:

May 10th. to June 15th.	Kamloops, Lac Le Jeune,	Project 410
June 16th. - July 1st.	Lilloet,	Project 406
July 2nd. - July 19th.	Forster Creek,	Project 407
July 20th. - July 31st.	Horse Thief Creek,	Project 411
August 1st. - August 15th.	Welsh Creek,	Project 407
August 16th. - September 11th.	Atlin,	Project #62

SEIGEL ASSOCIATES LIMITED
 GEOPHYSICAL CONSULTANTS & CONTRACTORS
 A DIVISION OF SCINTREX LIMITED

June 29th. 1971.

Invoice 71052.

Canadian Johns Manville Co. Ltd,
 P.O. Box 1500
 Asbestos, Quebec.

Re: Geophysical Survey
 Kamloops, British Columbia
 Contract 938A
 Interim Billing No.1.

A. Operator

May 10 to June 9,

Travel and Standby Days

May 10, 11, 25 and June 8,

4 Days @ \$90.00 360.00

Work Days 26/24 X 3,000.00

No Charge May 29, operator sick

3,250.00

3,610.00

B. Air Fare

357.00

Plus 10%

35.70

392.70

\$4,002.70

RESPONSIBILITY	
ACCOUNT NO.	787760
EXPLORATION PROJECT NO.	416
ENGINEERING PROJECT NO.	
APPROVED FOR	
MACHINE NO.	
APPROVED FOR PAYMENT	

J.S. Bortnick

Mr. Bortnick is a High School graduate (Alberta, 1947). Since graduation he has been employed continuously in geophysical exploration programs, both as an instrument operator and as a party leader. He has experience in oil exploration both in Canada and the U.S.A., while since 1953 he has been exclusively employed in mining geophysical exploration in Canada, the U.S.A., Mexico, Oceania and Africa. He is considered to be a Senior Instrument-Operator and Party Leader, being experienced in all instruments and techniques of ground geophysics.

He speaks, reads and writes both French and English, and in addition speaks Russian, Ukranian and Polish.

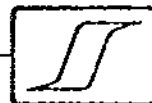

STATEMENT OF QUALIFICATIONS

I, Herbert Keith Conn, of the town of Asbestos, do hereby declare that:

1. I am a mining geological engineer employed as Exploration Manager for Canadian Johns-Manville Company, Limited, P.O. Box 1500, Asbestos, Quebec.

2. I have practised in the geological profession for twenty-two years and specialized in economic geology and exploration procedures for the past twenty-one years.

3. I am a graduate of the University of Toronto, Toronto, Ontario, with a degree of B.A.Sc. (Mining Geology), 1948.

4. I am a member of the following professional associations:

- (a) Corporation of Engineers of Quebec
- (b) Non-resident member of the Association of Professional Engineers of the Province of British Columbia
- (c) Fellow of the Geological Association of Canada
- (d) Fellow of the Society of Economic Geologists
- (e) Member of the Canadian Institute of Mining and Metallurgy
- (f) Member of the American Institute of Mining Engineers

5. This report is based on published and unpublished information.

March 1972

H.K. Conn, P.Eng., Exploration Manager
Canadian Johns-Manville Co., Limited



1. I, Jan Klein, reside at 375 Cloverdale Court, Newmarket, Ontario.
2. I have an M. Sc. (1965) from the Technical University of Delft, The Netherlands.
3. I am a Professional Engineer in the Province of Ontario.
4. I possess experience in both airborne and ground geophysics.
5. I have worked in Europe, Africa, South America and Canada.
6. I am a member of the Society of Exploration Geophysicists (SEG), the European Association of Exploration Geophysicists (EAEG), and the Canadian Exploration Geophysicists Society (CEGS).

Dated at Toronto, Ontario this

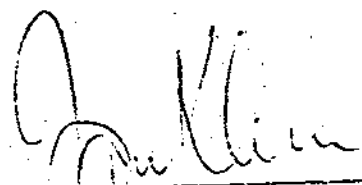

J. Klein, M. Sc., P. Eng.



Philip Robertshaw obtained an M.Sc. in geophysics from the Royal School of Mines, University of London, England, in 1970. He has had experience in many ground geophysical techniques in a wide range of climatic conditions in Canada, the U.S.A., Mexico and Europe.



Induced polarisation method

By Dr. HAROLD O. SEIGEL
President, Scintrex Limited

REPRINTED FROM THE
OCTOBER 1970 ISSUE OF...

MINING
IN CANADA

for



SCINTREX

The induced polarization method is based on the electrochemical phenomenon of Overvoltage, that is, on the establishment and detection of double layers of electrical charge at the interface between ionic and electronic conducting material when an electrical current is caused to pass across the interface.

In practice, two different field techniques (Time Domain and Frequency Domain) have been employed to execute surveys with this method. These techniques can yield essentially equivalent information but do not always do so. Instrumentation and field procedures using both techniques have evolved considerably over the past two decades. Much theoretical information for quantitative interpretation has been accumulated.

All naturally occurring sulphides of metallic lustre, some oxides and graphite, give marked induced polarization responses when present in sufficient volume, even when such materials occur in low concentrations and in the form of discrete, non-interconnected particles.

Induced Polarization is the only method presently available which has general application to the direct detection of disseminated sulphide deposits such as "porphyry type" or bedded copper deposits, and bedded lead-zinc deposits in carbonate rocks.

A number of case histories are documented where standard geo-electrical and other geophysical

methods failed to yield an indication of sulphide mineralization detectable by the induced polarization method.

Each rock and soil type exhibits appreciable induced polarization response, usually confined to a relatively low amplitude range, which is characteristic of the specific rock or soil. Certain clays and platy minerals including serpentine, sericite and chlorite, sometimes give rise to abnormally high responses. These effects are attributed largely to so-called "membrane" polarizations.

Despite a moderate amount of laboratory and field investigation, it is not feasible in general to differentiate between induced polarization responses due to Overvoltage and non-metallic sources, nor to differentiate between possible sources within each group.

Because of other variables, it is likewise difficult to uniquely equate a specific induced polarization response to a specific percentage of metallic content, although mean relationships have been established.

Through the measurement of secondary parameters, such as the transient decay curve form characteristics, one may obtain useful information relating to the average particle size of metallic responsive bodies or to the influence of electromagnetic transients on the I.P. measurements. The latter effect becomes prominent when surveys are made in areas with highly conducting surface materials, e.g. semi-arid regions.

Induced polarisation method

By Dr. HAROLD O. SEIGEL
President, Scintrex Limited

THE induced polarization (or I.P. as it is commonly known) method is, in application, the newest of our mining geophysical tools, having come into active use only in late 1948. Its roots extend somewhat farther back, however. Schlumberger (1920) reports having noted a relatively lengthy decay of the residual voltages in the vicinity of a sulphide body after the interruption of a primary D.C. current. Unfortunately, measurements in non-mineralized areas gave rise to rather similar residual polarization potentials, so he apparently abandoned his efforts.

In the late 1930's in the U.S.S.R. (Dakhnov, 1941) I.P. measurements were being made in petroleum well logging in an attempt to obtain information relating to the fluid permeability of the formations traversed by the well. Dakhnov mentions the possible application of the method to the exploration for sulphide mineralization, although it would appear that no such use was being made use thereof at that time. Unfortunately the volume of Dakhnov did not come to the attention of abstracters in North America until the spring of 1950.

Active development of the I.P. method as applied to mineral exploration in North America commenced with the writer's theoretical study in 1947 of the phenomenon of Overvoltage and his report (Seigel, 1948) on its possible application to geophysical prospecting. Laboratory and subsequent field investigation, sponsored by Newmont Mining Corporation in 1948 eventually led to the development of a working field technique and the recognition of polarization effects in all rocks (Seigel 1949).

Contemporaneously and independently D.A. Bleil (Bleil 1953) indicated the possibility of utilizing

I.P. in prospecting for magnetite and sulphide mineralization but apparently did not recognize the presence of non-metallic polarization effects in rocks.

Until 1950 all I.P. measurements were of the "time-domain" type (see below). In 1950, as the result of some laboratory measurements, L.S. Collett and the writer suggested the method of measuring I.P. effects using sinusoidal current forms of different frequencies. J.R. Wait expanded greatly on the possibilities of this approach and successful field tests were carried out in that year. The work of the Newmont group is summarized in a monograph (Wait 1959).

Since 1950 several groups have been active in the development of the I.P. method by means of theoretical laboratory model and field studies. Prominent among these groups has been that at the Massachusetts Institute of Technology (Hall of 1957) (Madden 1957) (Marshall 1959).

Within the literal meaning of the term, polarization is a separation of charge to form an effective dipolar distribution within a medium. Induced polarization is, therefore, a separation of charge which is due to an applied electric field. It may also include phenomena which cause voltage distributions similar to those due to true polarization effects.

For practical purposes, only polarization effects with time constants of build up and decay longer than a few milliseconds are of importance. This usually excludes such phenomena as dielectric polarization and others which are encompassed by the normal electromagnetic equations.

In order to measure I.P. effects in a volume of rock one passes current through the volume by means of two contact points or electrodes and

measures existing voltages across two other contact points.

Theoretically, any time varying current form can be used, but in practice only two such forms are employed. In the first technique a steady current is passed for a period of from one second to several tens of seconds and then abruptly interrupted.

The polarization voltages built up during the passage of the current will decay slowly after the interception of the current and will be visible for at least several seconds after the interception. This is termed the "Time Domain" method.

The "Frequency Domain" method entails the passage of sine wave current forms of two or more low, but well separated, frequencies, e.g. 0.1 and 2.5 c.p.s., or 0.5 c.p.s. and 10 c.p.s.

Since polarization effects take an appreciable time to build up, it can be seen that they will be larger at the lower frequency than at the higher, so that apparent resistivities or transfer impedances between the current and measuring circuits will be larger at the lower frequency. The change of measured resistivities with frequency is, therefore, an indication of polarization effects.

Further discussion of the precise quantities measured in the Time and Frequency Domain methods will be resumed after a presentation of some of the polarization phenomena involved.

When a metal electrode is immersed in a solution of ions of a certain concentration and valence, a potential difference is established between the metal and the solution sides of the interface. This difference in potential is an explicit function of the ion concentration and valence, etc.

When an external voltage is applied across the interface a current is caused to flow and the potential drop across the interface changes from its initial

value. If the electrode is a cathode it becomes more negative with respect to the solution, whereas if it is an anode, it becomes more positive with respect to the solution.

The change in interface voltage is called the "Overvoltage" or "Polarization Potential" of the electrode. If the electrode is a cathode, we speak of "Hydrogen Overvoltage" and, if an anode, of "Oxygen Overvoltage".

These Overvoltages are due to an accumulation of ions on the electrolyte side of the interface, waiting to be discharged. The charge of these ions will be balanced by an equal opposite charge due to electrons or protons on the electrode side of the interface.

For small current densities the Overvoltage is proportional to the current density, i.e. is a linear phenomenon. The variation of Overvoltage with several other factors is presented in the writer's Doctoral Thesis. (Seigel, 1949). The time constant of build up and decay is of the order of several tenths of seconds.

Overvoltage is, therefore, established whenever current is caused to flow across an interface between ionic and electronic conduction. In normal rocks the current which flows under the action of an impressed E.M.F. does so by virtue of ionic conduction in the electrolyte in the capillaries of the rock.

There are, however, certain rock forming minerals which have a measure of electronic conduction, and these include almost all the metallic sulphides (except sphalerite), graphite, some coals, some oxides such as magnetite, and pyrolusite, native metals and some arsenides and other minerals with a metallic lustre.

When these are present in a rock subjected to an impressed E.M.F., current will be caused to flow across capillary - mineral interfaces and

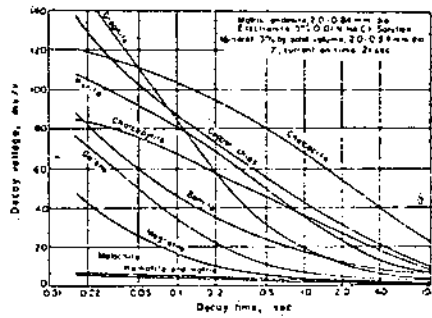

FIGURE 2
Decay Curves for Metallic and Non-metallic Minerals (after Wait, 1959).

hydrogen and oxygen Overvoltages will be established. Figure 1 is a simplified representation of what happens to an electronic conducting particle in a rock under the influence of current flow.

Despite attempts by various workers to investigate the source of non-metallic I.P. in rocks, an adequate explanation of all observed effects is still lacking. A number of possible contributory agents have been established. Vacquier (Vacquier et al, 1957) has carefully examined strong polarization effects due to certain types of clay minerals.

These effects he believed to be related to electrodiolysis of the clay particles. This is only one type of phenomenon which can cause "ion-sorting" or "membrane effects".

For example, a cation selective membrane zone may exist in which the mobility of the cation is increased relative to that of the anion, causing ionic concentration gradients and, therefore, polarization effects (see also Marshall, 1959). Much work remains to be done to determine the various agencies, other than clay particles, which can cause such membrane effects.

Time Domain Method: Figure 2 shows the typical transient I.P. voltage decay forms for various rock forming materials in a laboratory testing apparatus. See also Scott (1969). A primary current time of the order of 21 seconds was employed on these tests.

It will be noted that the voltages are plotted against the logarithm of the decay time and are approximate linear functions of the log t for reasonable lengths of time (t). The amplitude of the transient voltages has been normalized with respect to the steady state voltage existing immediately before the interception of the primary current.

In order to indicate the magnitude of the I.P. effects one may measure one or more characteristics of the transient decay curve and relate it back to the amplitude of the measured

primary steady state voltage prior to the interception of the primary current.

It may be shown that the ratio is V_s/V_p , i.e. peak polarization voltage to the primary voltage just before interception is a physical property of the medium, which has been called the "Chargeability" of the medium.

Since it has been demonstrated that most I.P. decay voltages are similar in form but differ in amplitude (for the same charging time) one can take the average of several transient voltages at different times, or indeed use the time integral of the transient voltages as a diagnostic criterion. The advantage of averaging or integrating lies in the suppression of earth noises and of electromagnetic coupling effects.

The chargeability is often designated by the letter "M". If the time integral is used the units of M will be in millivolt seconds/volt or milliseconds. If one or more transient voltage values are measured and normalized, M will be dimensionless.

For homogeneous, isotropic material, the value of M is independent of the shape or size of the volume tested and of the location of the electrodes on it. It is a true physical property. For a given medium it is dependent on the current charging time and on the precise parameter of the decay curve measured. There are also subsidiary variations with temperatures and electrolyte content, etc.

Frequency Variation Method: Figure 3 shows typical curves of the variation of normalized resistivities with frequency for various sulphide, graphite and non-metallic rock minerals in artificial mixtures. Both the fact of the variation of apparent resistivity with frequency and the presence of phase angle lags may be used to indicate the presence of I.P. effects, although generally only the first is so employed.

Since the I.P. phenomena may be shown to be linear, within the usual range of voltages and currents, there is

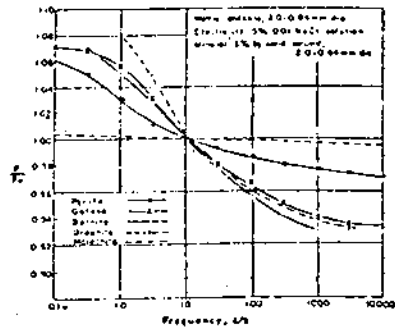
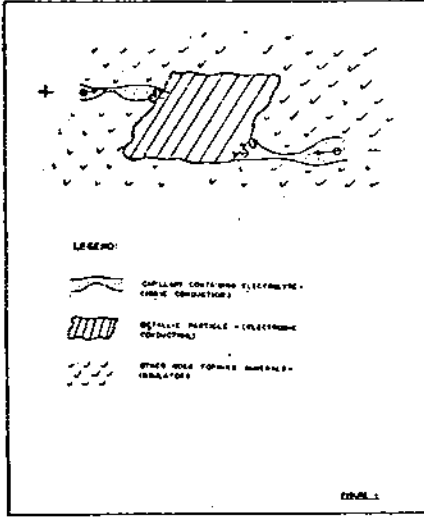
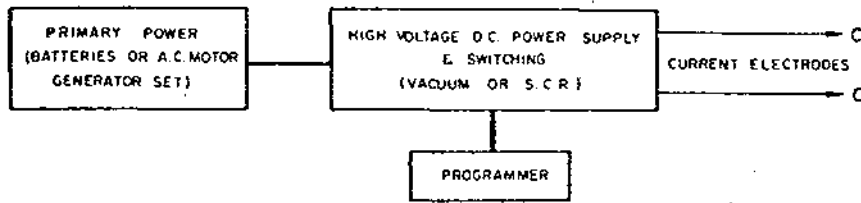

FIGURE 3
Resistivity-frequency Characteristics of Metallic and Non-metallic Minerals (after Wait, 1959).



Induced Polarization Response of a Metallic Conducting Particle in a Rock.

TRANSMITTER



RECEIVER



WAVE FORMS

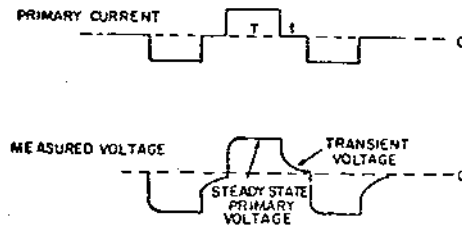

Time Domain Apparatus, Block Diagram and Wave Forms.

a direct relationship between the transient curve form and the variation of apparent resistivity with frequency. To arrive at a dimensionless parameter equivalent to the chargeability, one would have to normalize the apparent resistivity, by dividing by the resistivity at one particular frequency. The factor used is called the "Percent Frequency Effect" or P.F.E. and is defined as $(R_1 - R_2 / R_1) \times 100$ where R_1 and R_2 are the apparent resistivities at the lower and higher frequencies used (Marshall, 1959).

A second parameter is sometimes employed which is really a mixture of physical properties. It is called the Metal Factor (M.F.) and is proportional to P.F.E./ R_2 or to M/R . As such, it serves to emphasize I.P. effects which occur in obviously conductive environments, i.e. concentrated sulphide deposits or sulphides and graphite in shear zones.

Since it is not a dimensionless factor nor a true single physical property, it is subject to variation related to the changes of shape and resistivity of the medium under investigation, rather than simply to variations in polarization characteristics.

In my opinion, the metal factor has some merit in emphasizing I.P. anomalies due to concentrated metallic bodies, but should not be used as a primary indicator of abnormal I.P. conditions.

Figure 4 shows a block diagram of apparatus commonly used in field operations with the time-domain method and the primary current and resultant voltage wave forms. The transient voltage amplitudes are considerably exaggerated to be visible.

Power sources up to 30 K.V.A., 5000 volts and 20 amperes have been employed where extreme penetration is desired in low resistivity areas. The current-on time T ranges from one

second to as much as 30 seconds, and the current-off time t may be as much as 10 seconds. It is not strictly necessary to employ a cyclic current wave form, but considerable advantages in signal-to-noise ratio are achieved thereby.

Most of the receivers now employed are remote triggering, i.e. they are internally programmed, triggered by the primary voltage pulse and do not require a cable interconnection to the cycle timer on the power control unit. Figure 5a shows a typical time-domain remote-triggered receiver (Scintrex MK VII, Newmont-Type). This particular receiver has several interesting features.

For one, there is a memory circuit which provides an automatic self potential adjustment at the tail end of each cycle. For another, it has the ability to integrate the area either below the transient curve (standard M measurement) or above the transient curve (denoted as the L measurement) over a specific time interval. The ratio of these quantities gives a direct

FIGURE 4

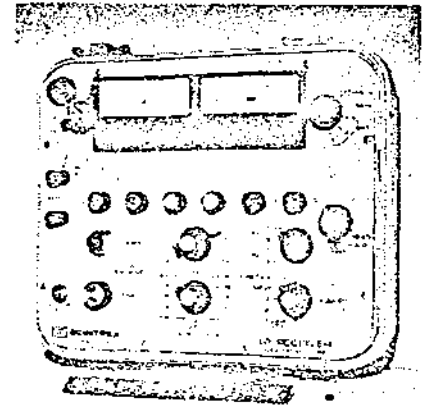

Typical Modern Time Domain I.P. Receiver (Scintrex Mk. VII)

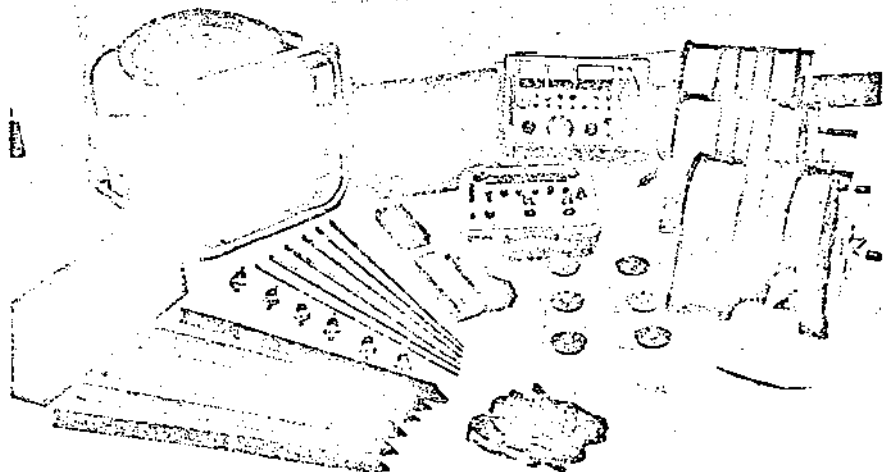

Typical Modern Time Domain I.P. Unit (Scintrex Mk VII)

FIGURE 5b

Array	Domain Employed	Advantages	Disadvantages
Wenner	Time	For local vertical profiling.	Poor depth penetration. Requires four linemen.
Three ² Electrode (or Pole-Dipole)	Time and Frequency	Three linemen. Universal coupling. Good depth penetration.	Susceptible to surface masking effects.
Dipole-Dipole	Frequency	Good resolution. Universal coupling.	Complex curve forms. Low order signals. Susceptible to surface masking effects.
Gradient	Time	Minimum masking. Two linemen only. Excellent depth penetration. Excellent resolution. Can use multiple receivers for speed.	Couples best with steeply dipping bodies. Low order signals.

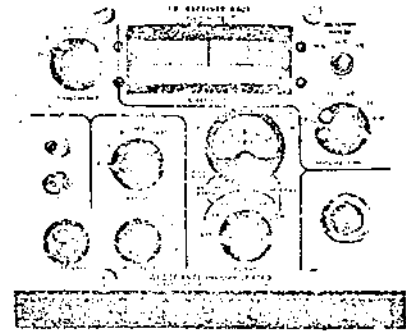

Typical Modern Frequency Domain Receiver (Geoscience).

It measures both the primary voltage and the change of primary voltage with change in operating frequency, the latter to an accuracy of about $\pm 0.3\%$ when the former exceeds 100 microvolts. It has the added feature of a phase lock voltmeter which assists in making measurements under low signal-to-noise conditions.

Common field electrode arrays are shown in Figure 8. The electrodes marked C are current electrodes and those marked P are potential or measuring electrodes. Each of the electrode arrays has its own advantages and disadvantages in respect of depth of penetration, labour requirements for moving, susceptibility to earth noise, electromagnetic earth transients and interline coupling. The following table summarizes the features of these arrays.

For each array (except the gradient array) the basic electrode spacing "a" is selected to give adequate penetration down to the desired depth of exploration. For the pole-dipole and double dipole it is customary to obtain several profiles for different values of "a" or for integral values of n from 1 to as much as 4.

For the symmetric arrays (Wenner and Dipole-Dipole) the measured values are plotted against the midpoint of the array. When using the Three Electrode Array (time-domain) the station position is taken to be the midpoint of the moving current and the nearest potential electrode. When using the Pole-Dipole (frequency domain) the station position is taken as the midpoint between the moving current electrode and the midpoint of the two potential electrodes.

With the Gradient array it is the midpoint of the two potential electrodes. For the Three Electrode array and Pole-Dipole these station locations are not unique and represent conventions only.

I.P. data may be plotted in profile form or contoured, although it should be noted that somewhat different results will be obtained with different line orientations so that contouring is

measure of the decay curve form, which may be of diagnostic value (see below). In areas of low electric earth noise useful measurements may be made with primary voltages as low as 300 microvolts. Figure 5b shows a complete typical modern time domain induced polarization unit (Scintrex MkVII) of which the Newmont-type receiver above is a part.

Figure 6 shows a block diagram of a typical frequency domain field apparatus and voltage wave form. Since the primary current and earth voltages are usually measured by

separate devices and their ratio employed to obtain the apparent earth resistivity and its variation with frequency, it is common practice to adjust the current to a standard value and maintain it there to the required accuracy.

The primary wave form is usually a commutated D.C. Commonly, up to 6 frequencies are available in the range of 0.05 to 10 c.p.s. Figure 7 shows a typical modern frequency domain measuring unit. This unit has a high degree of power line frequency (50 c.p.s. to 60 c.p.s.) rejection.

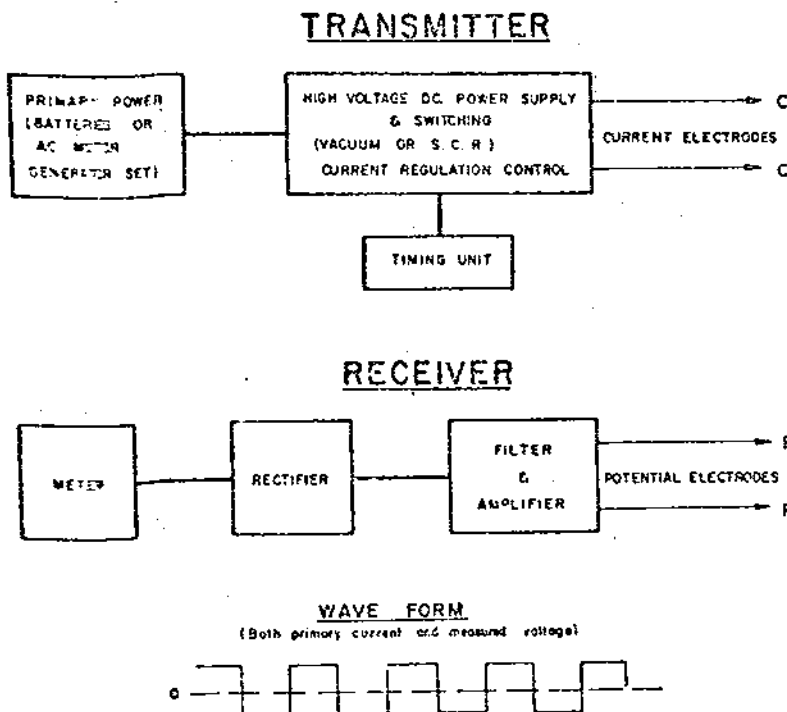
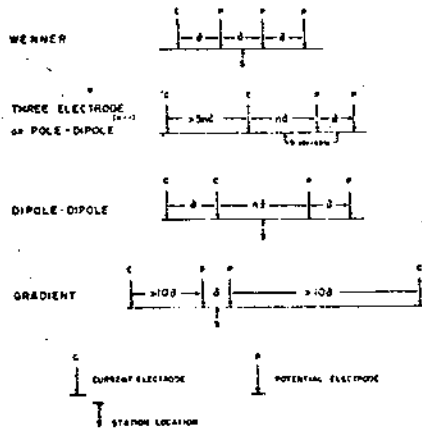
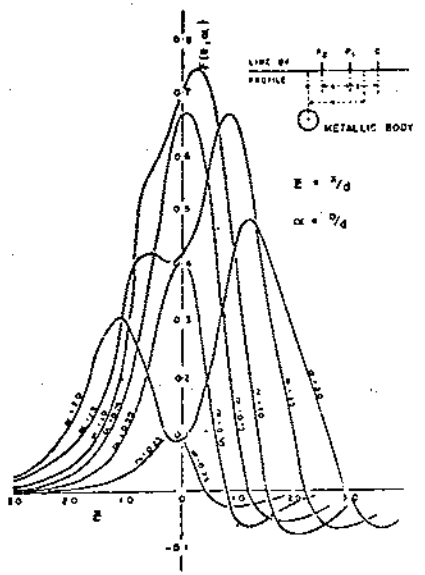

FIGURE 6

Frequency Domain Apparatus, Block Diagram and Wave Forms.



Common Field Electrode Arrays.



Theoretical Response of a Sphere, Three Electrode Array.

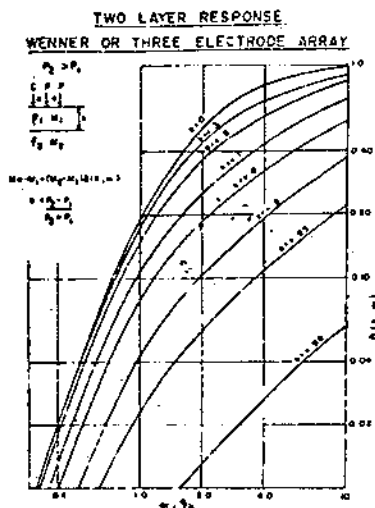

Theoretical Response of Two Layer Earth, Wenner or Three Electrode Array.

not strictly justified. Profile interpretation is superior, particularly for shallow, confined bodies, because multiple peaked curves may arise from such bodies using certain electrode arrays, and the plotted peaks may give an erroneous impression of the location of the polarizable body.

To obtain the variation of physical properties with depth, expanding arrays may be used with any of the electrode systems, keeping the spread centre fixed and simply changing the relative spacing "a". This is of particular value where it is known or expected that vertical variations of physical properties will be much greater than lateral variations.

As the spacing is increased the influence of the deeper regions becomes more significant, and the resultant resistivity and I.P. curves may often be interpreted to give the depth to discontinuities in physical properties and the physical properties themselves.

Common practice in presenting frequency domain results is to plot the measured data below the line at a depth equal to the distance of the station position (as defined above) from the midpoint of the potential dipole. When this is done for a variety of values of "n" a pseudo two-dimensional section results which show, albeit in a markedly distorted fashion, the variation of physical properties with depth.

A mathematical representation of I.P. effects has been developed by the writer (Seigel, 1959), which relates the observed I.P. response of a heterogeneous medium to the distribution of resistivities and I.P. characteristics. To a first approximation it is equally applicable to any I.P. parameter measured in the time and frequency domains.

From this theory, one may predict the anomalous response to be

expected from a specific body with a given chargeability and resistivity contrast. For example, Figure 9, shows the form factor F plotted for the Three Electrode Array for a sphere for various values of λ , where λ is the ratio of the electrode spacing to the depth of the centre of the sphere. The sphere response is proportional to F times the chargeability contrast, times its volume and times a resistivity-ratio factor. A number of such theoretical curves, for the pole-dipole and gradient arrays, using spheres and ellipsoids as models, may be seen in the paper by Dieter (1969) et al.

Curves of this sort permit one to interpret anomalies due to localized bodies. It will be seen that for each array there is an optimum spacing for a body at a particular depth, and, therefore, there is some meaning to the term "depth of penetration", except for the gradient array.

When the dimensions of the polarizable medium are large in comparison with its depth below surface, as is often the case, particularly in investigation of porphyry copper type deposits, a two layer approximation is adequate. Theoretical curves based on this approximation (Figure 10) may be used to interpret the results of expanding Wenner or Three Electrode array depth determinations.

For more complex geometries, mathematical solutions in closed form are often lacking. For such cases one may resort to model studies (e.g. Figure 11 for buried dike.) or to computer calculated solutions.

The most productive use of the I.P. method to date has been in the exploration for deposits of metallically conducting minerals, where the amounts and degree of interconnection of these minerals are too low to give rise to an electromagnetically detectable body.

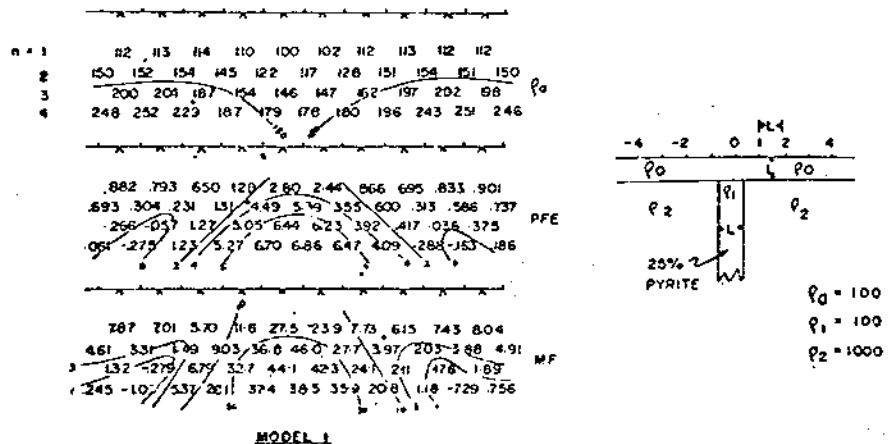

Model Response of a Dike, Dipole-Dipole Array (courtesy K. Vozoff).

FIGURE 11

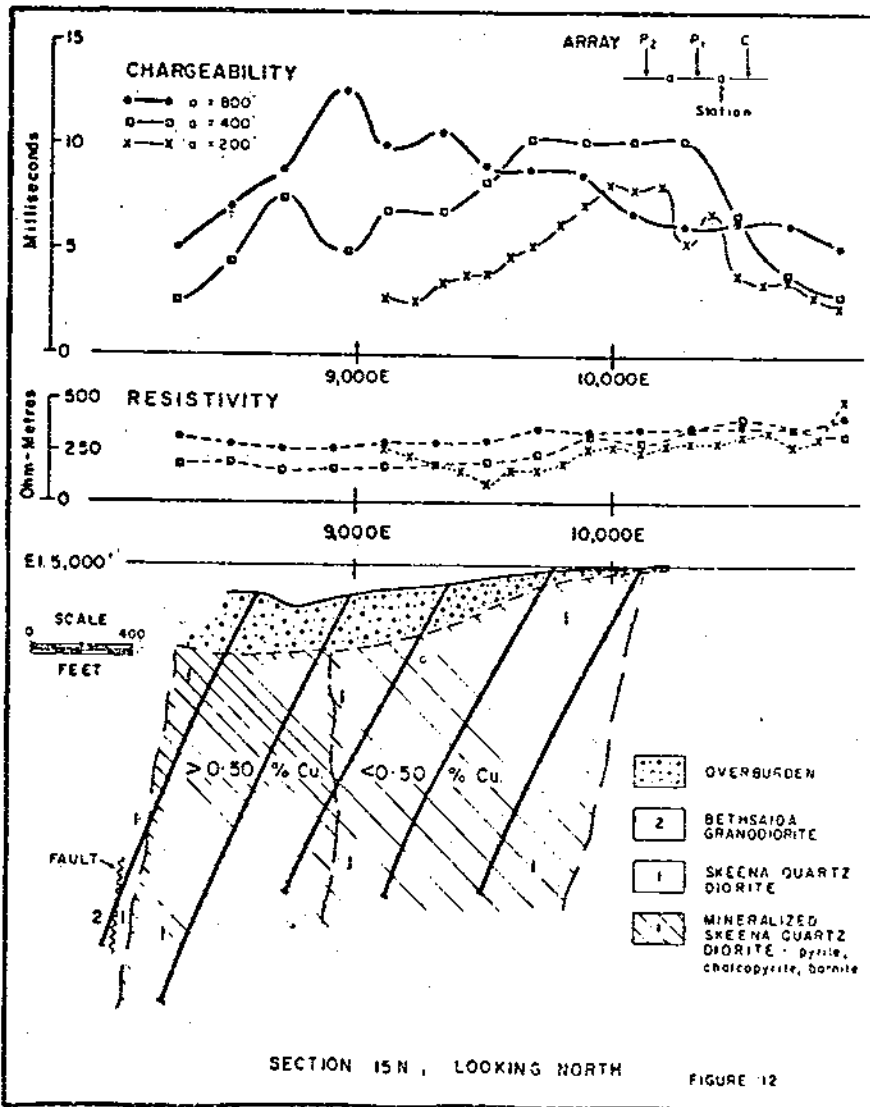

Geophysical and Drilling Results, Lornex Porphyry Copper Ore Body, British Columbia, Canada (courtesy Lornex Mining Corp. Ltd.)

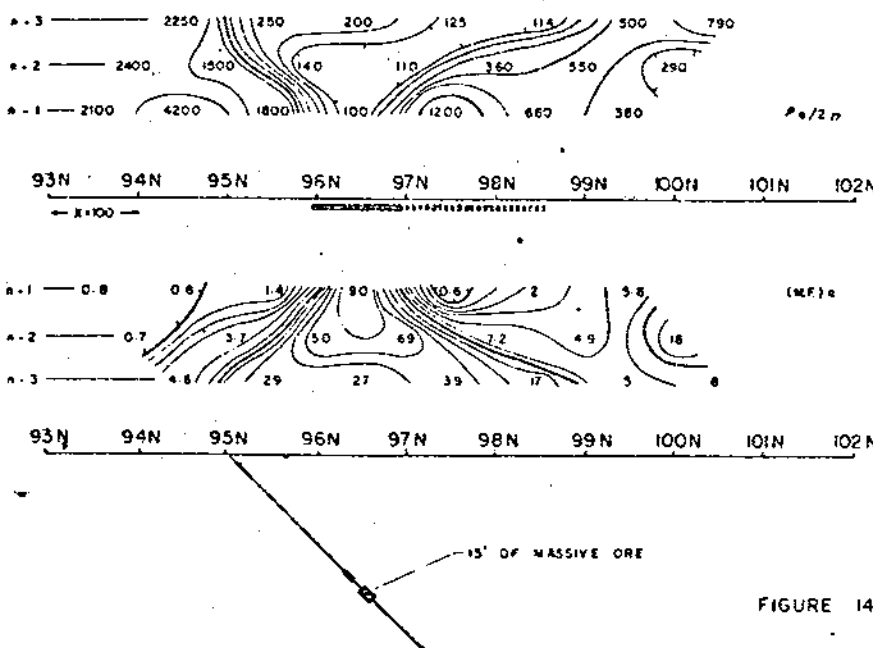

Geophysical and Drilling Results Lead-Zinc-Copper Ore Body, Heath Steele Mine, New Brunswick, Canada (courtesy P. Hallof).

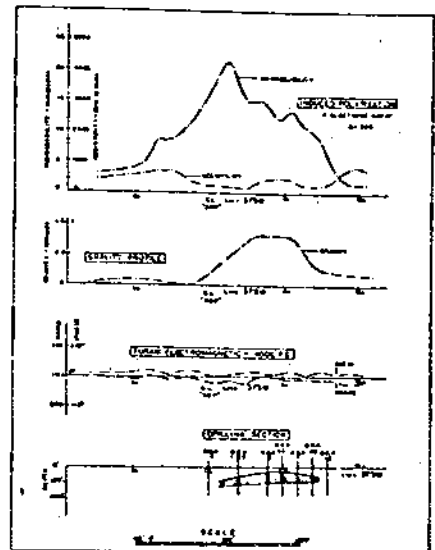

FIGURE 13

Geophysical and Drilling Results, Pyramid No. 1 Lead-Zinc Ore Body Pine Point Area, Northwest Territories, Canada (courtesy Pyramid Mines, Ltd.).

Where electromagnetic detection is feasible it is usually far more rapid and economical to apply electromagnetic induction methods to the problem. The I.P. method is the only geophysical tool available which is capable of direct detecting 1 percent or less by volume of metallic conducting sulphides.

It is best used, therefore, where there is a high ratio of economic minerals to total sulphide mineralization. Included in the proper I.P. range are such types of deposits as disseminated copper ores, in porphyry or bedded forms; lead-zinc deposits, particularly of the bedded type in carbonate rocks; gold and other deposits which have an association with disseminated metallic conductors. For many of these mineral occurrences the I.P. method is unique in providing detection.

Figure 12 shows time-domain discovery traverses over a typical newly discovered porphyry copper deposit in British Columbia. The lateral limits of the mineralization can be readily determined from the geophysical data, as well as the depth to the upper surface of the mineralization.

Figure 13 shows a discovery traverse over a major bedded body of sphalerite-galena-marcasite mineralization in carbonate rocks in the Pine Point area, Northwest Territories, Canada. For comparison purposes both gravity and Turam electromagnetic profiles on the same section are shown.

It is interesting to note that, despite an appreciable resistivity depression over the mineralization there is no significant Turam response at 400 c.p.s. The conductivity of the ore is, in fact, no higher than that of the surficial deposits in the general area, so that

electromagnetic and resistivity methods yield, in themselves, no useful information.

The gravity method, although yielding a positive response in this instance, does not provide a good reconnaissance tool in this area because of karst topography and other sources of changes in specific gravity.

One occasionally encounters a deposit of the "massive sulphide" type which is normally thought of as an electromagnetic type of target because of its high conducting sulphide content, but which, obviously because of the lack of large scale continuity of the conducting sulphides, does not respond to the electromagnetic techniques. Figure 14 shows an intersection of ore grade material of this type, in New Brunswick, Canada, where electromagnetic methods had yielded negative results.

In many types of ore deposits the bulk of the I.P. response is due to the accessory non-economic sulphides, usually pyrite and pyrrhotite, and the ore minerals themselves are in the minority. A true test of the sensitivity of the I.P. method is an example of a low grade disseminated deposit with no such accessory minerals. Figure 15 illustrates such a case, with an I.P. discovery section over the Gortdrum copper-silver-mercury deposit in Ireland. The ore minerals consist of chalcocite, bornite and chalcopyrite in a dolomitic limestone, and there is less than 2% average by volume of metallic conducting minerals.

Whereas the bulk of I.P. measurements in mineral exploration has, naturally, been made on surface, the technology of drill hole exploration has been well developed, particularly by the Newmont group (see Wagg, 1963). The time-domain method is suitable for drill hole applications since it permits a relatively close coupling of the current and potential lines in a small diameter bore hole.

The three electrode array has been extensively employed for logging purposes, with a variety of electrode spacings to give varying ranges of detection away from the hole. In this fashion the variation of electrical properties with distance from the hole may be determined. A second, "directional log" then gives information on the direction of any anomalous material indicated by the detection log.

Whereas the I.P. method is usually employed as a primary exploration tool it may play an auxiliary role as well, e.g. to distinguish between metallic and ionic conducting sources of other types of electrical anomalies, e.g. electromagnetic.

Figure 16 shows a typical conducting zone revealed by a ground

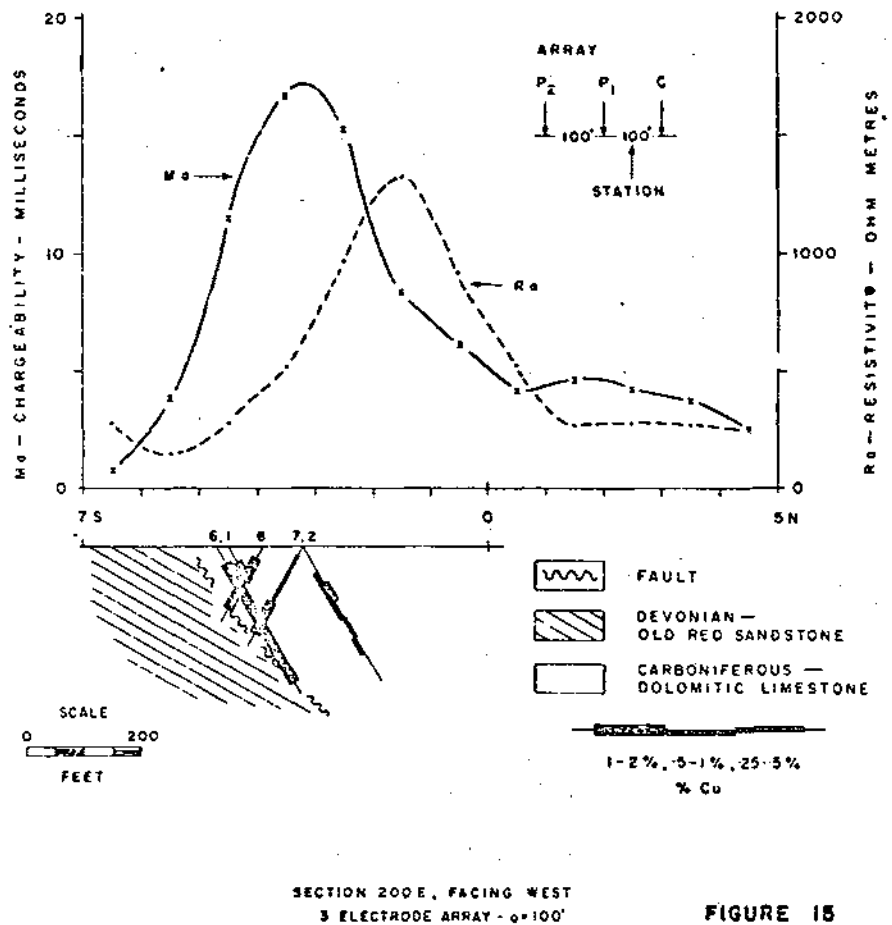

SECTION 200 E, FACING WEST
3 ELECTRODE ARRAY - $\rho = 100'$

FIGURE 15

Geophysical and Drilling Results, Copper-Silver Ore Body, Gortdrum Mines, Ireland (courtesy Gortdrum Mines, Ltd.).

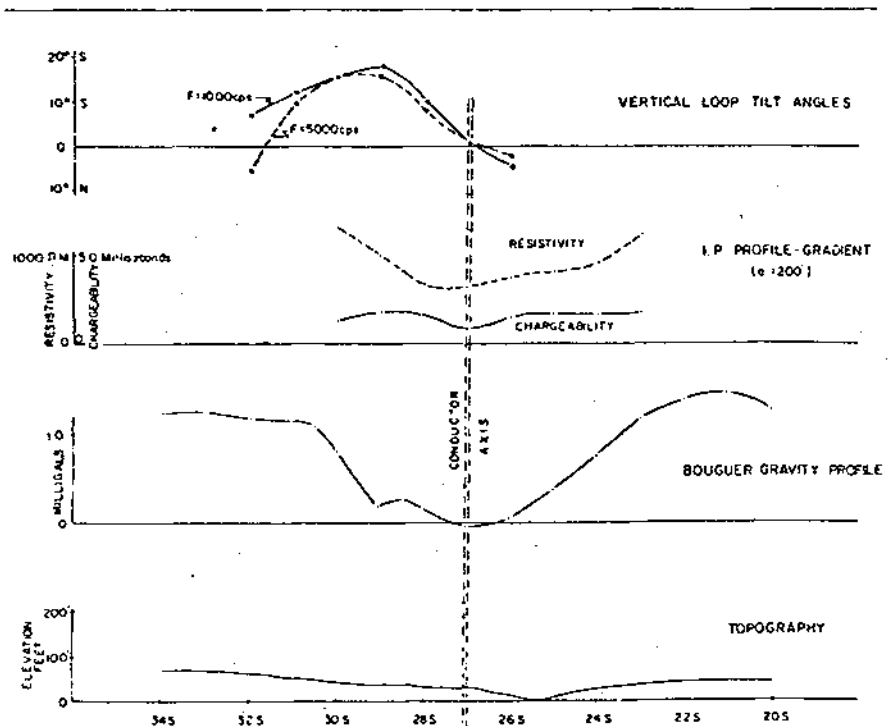

FIGURE 16

Geophysical Recognition of Overburden Trough, Northwest Quebec, Canada.

electromagnetic survey which was later proven, by drilling, to be due to overburden conduction in a bedrock trough. The I.P. response is in the low-normal range. The gravity profile, also shown, corroborates the presence of the bedrock depression.

Attempts have been made by a number of workers to employ the I.P. method in the field of groundwater exploration (e.g. Vacquier, 1957, Budmer, 1968) but with no consistent success as yet. There are variations of chargeability from one type of non-consolidated sediment to another, but these fall, in general, within a relatively small range compared to the usual sulphide responses.

More investigation remains to be done in this area before a definitive conclusion can be reached. It is clear that more accurate measurements will have to be made in groundwater I.P. than in base metal I.P. investigations.

The I.P. method has a number of recognized limitations, some of a fundamental nature and others of a temporary nature reflecting the current state of the art. On a unit coverage basis the method is relatively expensive to apply, costing between \$200 and \$500 per line mile surveyed, in most instances. This cost has, however, been progressively reduced by advances in instrumentation resulting in decreased weight, increased

sensitivity and rejection of earth noise effects. Some degree of improvement is yet to be expected in this area.

The same geometric limitations apply as with the resistivity method employing the comparable array. As a rule, a body of up to 10 per cent disseminated metallic conductors cannot be detected at a distance from its nearest point much exceeding its mean diameter. This detectability may be somewhat improved by the use of secondary criteria, but such improvement is likely to be only marginal.

Since Overvoltage is essentially a surface phenomenon the I.P. response from a given volume percentage of metallic conductors generally increases as the individual particle size is decreased. From the usual simple I.P. measurements, therefore, one cannot reliably predict the percentage by volume of such conductors in a deposit as there may be a variation of particle size throughout the deposit.

Still less can one differentiate between metallic conductors (e.g. chalcopyrite, galena, pentlandite) of economic interest and those of non-economic interest (e.g. pyrite, pyrrhotite and graphite). In addition we cannot even reliably differentiate between metallic sources of I.P. responses. The latter may include certain types of clay and, in consoli-

dated rocks, such platy alteration minerals as serpentine, talc and sericite.

Empirically it has been found that, on the average, 1% by volume of metallic sulphides will increase the chargeability by about 2 - 3 times, depending on the host rock type.

Figure 17 shows a section across each of two anomalous I.P. areas in the Pine Point area, Northwest Territories, Canada. Section A is a discovery traverse across an ore body containing one half million tons of 11.4 per cent combined Pb and Zn and coming within 40 ft. of the ground surface. Section B is a traverse across what proved, by drilling, to be a karst sink hole, filled in with a variety of unconsolidated material including boulders and clay.

Based upon the chargeability amplitudes and the relative resistivity depressions the second case would appear to be far more promising than the first. In such cases the gravimeter has sometime proven to be of value in resolving the two types of occurrence but there is the very real possibility of the coincidence of a sink hole and a lead-zinc deposit, which would give rise to an uncertain resulting gravity response.

Any normal transient (time-domain) polarization decay and equivalently any curve of variation of apparent resistivity with frequency may be simulated by means of a mixture of metallic conductors of a suitable particle size distribution.

It is, however, possible in an area of common geology, that the various possible sources of I.P. responses may have significantly different characteristic curves in each of these two domains. A more thorough analysis of these curves at significant points is, therefore, of value.

Modern receivers in both domains (Figures 5 and 7) have the ability to give curve form information as well as a single quantity related to an I.P. amplitude.

Komarov (1967) documents such an example over a copper-nickel deposit in the U.S.S.R. where, effectively the sulphide responses have a longer time constant than the normal non-metallic polarization.

An important source influencing I.P. measurements is the electromagnetic response of the earth. For a given electrode array the electromagnetic effect is dependent upon the frequency times the conductivity and the square of the spacing. In the frequency domain this source becomes troublesome (communication from P.G. Hallaf) when:

1. The electrode spacing is 500 ft. or over and $n = 3$ or greater.
2. The highest frequency employed is 2.5 c.p.s. or greater.

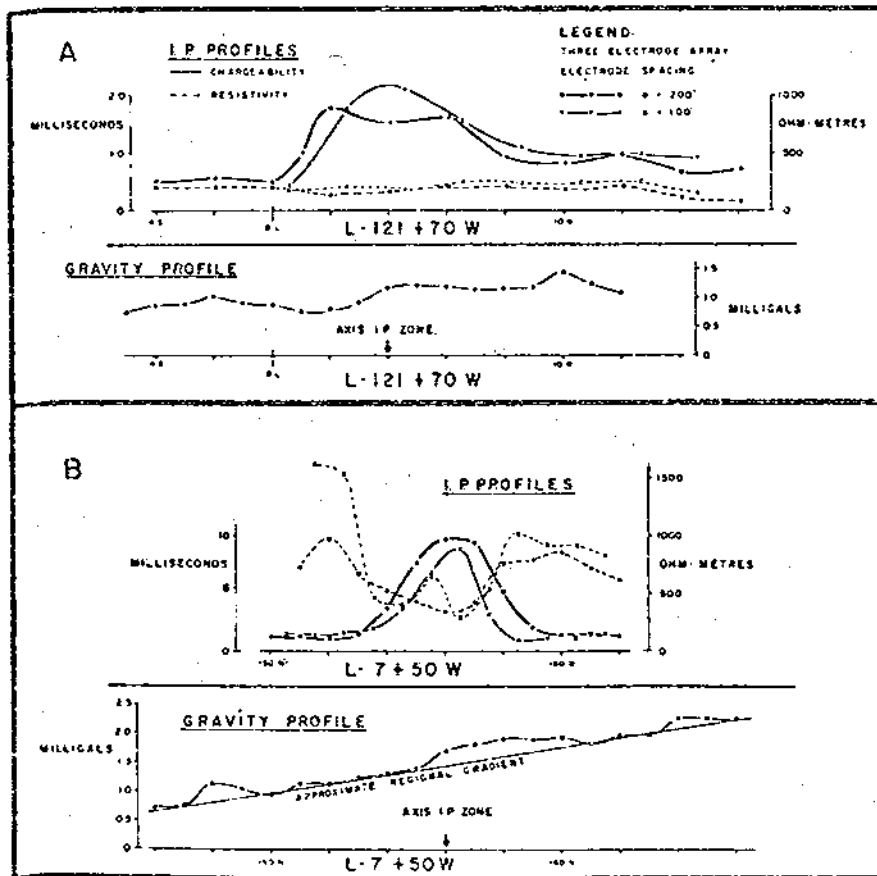

FIGURE 17

Possible Ambiguity of Induced Polarization Results, Pine Point Area, Northwest Territories, Canada.

3. The average earth resistivity is lower than about 25 ohm metres.

Electromagnetic effects are present in the time-domain measurements as well, of course, but are usually of lesser amplitude for the same array and earth conductivity, because the effective frequencies employed in the time domain are considerably lower (commonly 0.03 to 0.125 c.p.s.).

In the extreme, the electromagnetic response of a conducting earth may seriously interfere with useful I.P. measurements in either domain.

In the time domain I.P. measurements commonly only a single amplitude (at a specific time after current interruption) or an average amplitude over an interval of time after the current interruption is used to characterize the transient decay curve and act as a measure of the induced polarization characteristics of the medium in question.

It has been known since 1950 that useful secondary information is available in the shape of the transient decay curve associated with time domain induced polarization measurements. Equivalent remarks may be made in respect of frequency domain measurements where, instead of measuring the average slope of resistivity frequency over one decade of frequency, more information is obtained about the shape of this curve.

The type of information inherent in the curve shape relates primarily to two factors - (a) average metallic particle size associated with the source of an anomalous I.P. response, and (b) the presence of electromagnetic transients arising from highly conducting geologic units. For convenience we will restrict the following remarks to time domain measurements, although equivalent statements may be made in the frequency domain.

It has been established through laboratory measurements that (a) metallic conductors of large average particle size give rise to time domain decay curves of relatively long time constant, and (b) metallic conductors of small average particle size give rise to decay curves of relatively short time constant. For these reasons, if a shape factor as well as an amplitude factor of the decay curve can be established we may obtain information which is helpful in some of the following circumstances:

(1) very large or very small metallic particles - the response from these may distort the shape as well as the amplitude of the transient curve. Thus rather small amplitude anomalous metallic responses may be recognized in the presence of equal I.P. relief due only to non-metallic variations.

(2) two different types of anomalous

response materials, in the same survey area, but differing in average particle size and/or decay curve form - e.g. serpentine, graphitic particles of small average size and coarse grained metallic sulphides.

One additional and rather common circumstance is the presence of (ionically) highly conductive overburden or consolidated rock units (e.g. saline overburden or shales). These units can give rise to electromagnetic transients of sufficiently long time constant to affect the usual I.P. amplitude measurement.

The shape of the E.M. transient is, in practice, markedly different from that of the usual I.P. transient, having a much shorter time constant than the latter. In addition, the polarity of the E.M. transient is often reversed to that of the I.P. transient. Curve shape measurements can provide a clear indication of the presence of significant E.M. interference and even a semi-quantitative estimate of the latter, enough to allow a correction factor to be applied.

Equipment of the type illustrated in Figures 4 and 5 (e.g. Scintrex MK VII System) permit appropriate transient curve shape information to be obtained. Common to all the transmitters in this system is the ability to pass a repetitive, interrupted square wave pattern current

into the ground, as shown on Figure 4. The current-on time may be 2, 4, or 8 seconds and the current-off time may be likewise selected. Measurements of I.P. transient curve characteristics are made during the current-off time.

Figure 18 shows the quantities measured by the Newmont-type receiver. In these receivers one sets the gain of certain amplifiers common to both the primary voltage V_p and transient voltage V_t measurements so that these voltages are essentially normalized.

The usual amplitude measurement performed by these receivers consists of an integration of the area under the transient curve over a specified interval after the interruption of the primary current and is designated by the letter M - the "chargeability" namely, 0.45 seconds to 1.1 seconds.

The 0.45 second delay time allows most E.M. transients, switching transients and interline coupling effects to disappear prior to the making of the measurement. Different measuring intervals may be employed under specific conditions.

In addition to M, the Newmont-type MK VII receiver is equipped to measure a quantity "L" which is defined as the time integral of the area over the transient curve, for a specified time interval, taking as reference voltage the

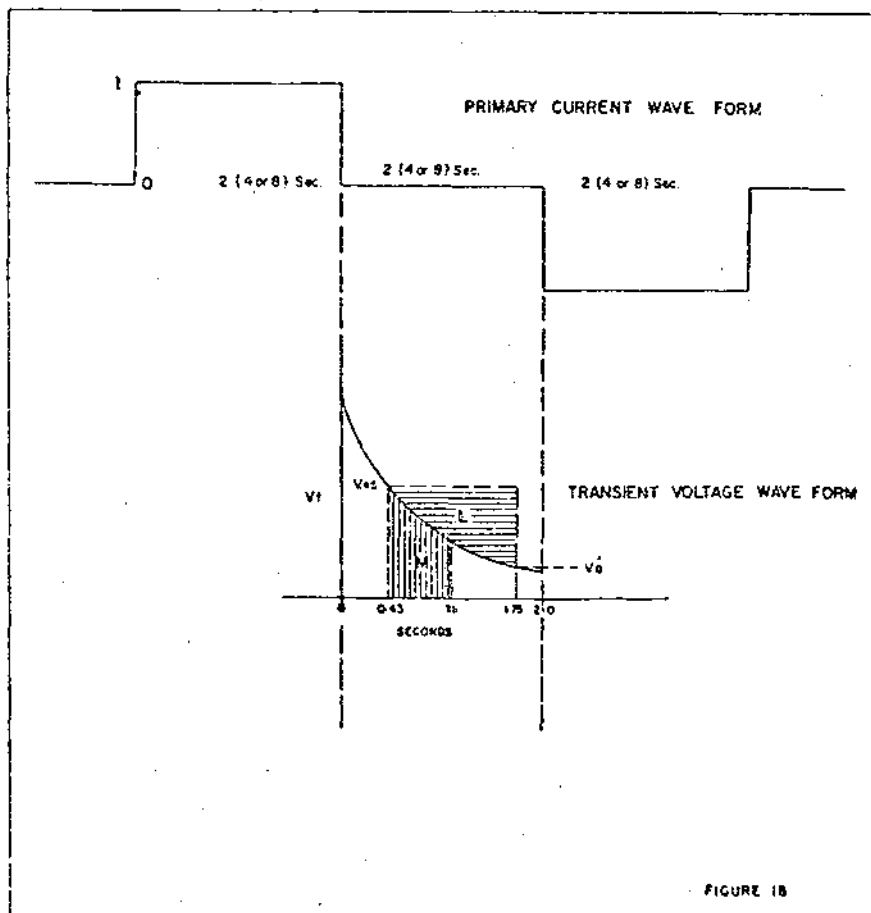

Operation of Scintrex Mk VII (Newmont-type) I.P. System.

transient voltage value at the beginning of the time interval. In practice, the interval selected is 0.45 seconds to 1.75 seconds, as shown on Figure 18, although different intervals may be employed under certain conditions.

The ratio of L/M is taken as a sensitive indication of transient curve shape. It has been well established, by many tens of thousands of I.P. measurements with these systems in many parts of the world, that the L/M measurements in non-metallically-mineralized areas, for a given current wave form, are constant within better than 20%.

Significant departures from these ratios usually imply an abnormal condition — either an anomalous metallic polarization response, electromagnetic or interline coupling.

Figure 19 shows a range of transient curves and their possible cause. For each case the "normal" transient curve is also shown. These cases illustrate the sensitivity of the L/M ratio to the transient time constant. A significant increase in L/M implies an abnormally short time constant, (Case A) reflecting either positive E.M. effects or small particle size. This should, in either case, normally be accompanied by an increase in apparent chargeability M.

A modest increase in L/M ratio, reflecting an increase in time constant (Case B) may reflect either the presence of large particle size metallic conductors, in which event an increase in M may or may not be appreciably reduced.

Cases C and D show the effect of reversed polarity E.M. transients of increasing amplitude. In Case C there is a short term Vt reversal and, although M is only slightly reduced, L/M is considerably reduced. In Case D, which is considerably more extreme, Vt is still rising at 0.45 seconds, so that L and thus L/M are, in fact, negative. M is considerably reduced from its normal value in this case, but a warning to this effect is clearly indicated by the L measurement.

A quantitative estimate of the E.M. transient response and, therefore, correction for it, may be obtained by one of a number of means. One may, for example, vary the current-on time, e.g. from 2 seconds to 8 seconds. The E.M. transient, being of relatively short time constant, will not change. The I.P. response will change by an amount which is fairly predictable, assuming a normal decay form. We thus obtain two equations in two unknowns from which the true I.P. response may be derived.

Curve shape measurements may be made in other ways as well, for example, by actually recording the complete transient decay curve. Whereas theoretically useful, such

measurements have proven unwieldy from a weight and time standpoint. To obtain clean decay curves requires a high signal/noise ratio and thus high powers.

In the frequency domain the equivalent curve form information would be obtained through the use of three or more properly selected operating frequencies.

There is a continuing rivalry between protagonists of time-domain and frequency domain measurements. All that is clear is that neither method is superior in all respects to the other. The same phenomenon is being measured in different ways often with different arrays and the results are presented different formats (pseudo-sections in the frequency domain versus profiles in or contour plans in the time domain).

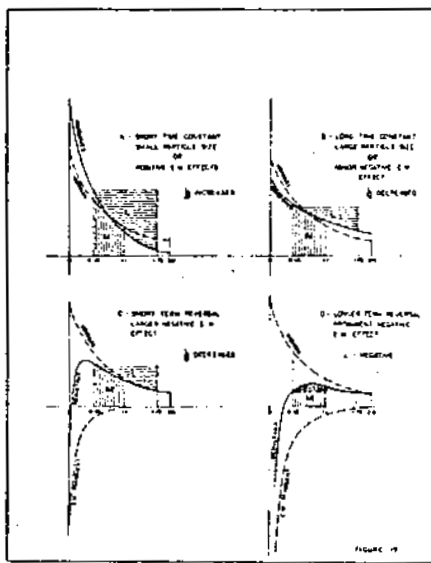

Significance of Curve Shape (L/M) Information.

The "Metal Factor", which is a mixture of physical properties, is commonly presented with frequency domain measurements only. These differences are largely superficial and are based on separate historical developments and subjective preferences.

There is a direct mathematical transformation between I.P. measurements in the two domains. Theoretically, at least, the same information can be obtained in either domain. Practically, however, there are certain differences.

The time domain measurements are absolute, i.e. are measured in the absence of the steady state voltage and are disturbed only by earth noises as a background. The amplitude of these measurements is usually less than 1% of the steady state voltage, but even so they can usually be made to an accuracy of better than 10 per cent even in unmineralized rocks.

The limit of useful sensitivity is related only to the regional uniformity of the background I.P. response. In the frequency domain the I.P. response is measured as a difference in transfer impedances. This difference can be measured with an accuracy of only 0.3% with extremely stable equipment. Since the non-metallic background P.F.E. over the interval of 0.1 to 2.5 c.p.s. is usually less than 1%, the probable error of these measurements may be 30% or more.

For this reason it is seen that it is feasible to obtain greater sensitivity of measurement in the time domain. This increased sensitivity is of value in areas of low "geologic" and electrical noise. By "geologic noise" is meant the range of variation of I.P. parameters within the normal rock types of the area. The application of I.P. to groundwater prospecting may have to develop through the time domain avenue because of the sensitivity requirements.

The frequency domain equipment requires somewhat less primary power than the time domain equipment because the former measurements in an A.C. one with the ability to use tuned filters and amplifiers as well as devices as phase-lock detectors. This advantage is not so marked as it once was, as current time-domain equipment, with its self adjusting earth voltage balance and ability to sum any desired number of integrations, provides a high degree of noise rejection.

Under truly random noise conditions the summation of n integrations provides the usual $1/\sqrt{n}$ reduction in statistical noise and is a powerful non-subjective means of noise suppression. The suppression of A.C. power line noise is much better with the time domain (integrating type) measurements than with frequency domain measurements.

Reference has already been made above to the relative effects of the electromagnetic response of the earth in both methods. Similar remarks apply to capacitive and inductive coupling effects between current and potential cables, although such effects can be largely avoided in any event by careful positioning of the cables, except possibly in drill hole surveying. So far, only in the time domain may useful drill hole measurements be made with both current and potential electrodes lying side by side in a small diameter bore hole.

An individual geologist or geophysicist may have had his first acquaintance with or instruction in the I.P. method using either the time domain or frequency domain. He becomes familiar with the arrays used and with the method of presentation of data employed. Thereafter, he tends to

resist switching to the other domain in the belief that not only will he have to deal with different geophysical equipment and electrode arrays but also with different quantities, presented in quite a different fashion. This is erroneous.

So far as arrays are concerned the time domain uses them all — dipole-dipole, pole-dipole (three electrode) Wenner and gradient (Schlumberger). The frequency domain commonly uses only the first two and is restricted from using the latter two because of interline coupling effects.

Of the quantities measured in both domains the resistivity is, of course, the same, making due allowance for units. The time domain "Chargeability" is, normally very nearly proportional to the "Percent Frequency Effect" or "P.F.E.". The so-called "Metal Factor" is the ratio of P.F.E./Resistivity, and would, therefore, be equivalent to the ratio of Chargeability/Resistivity.

The time domain data presentation

is commonly in the form of profiles and contour plans.

The frequency domain presentation is commonly in the form of "pseudo-sections" showing the different spacing results displaced progressively downwards with increased electrode spacing. Either type of data may be presented in either form of course, to suit the tastes and experience of the individual geologist or geophysicist.

The Gradient array is very useful in obtaining bedrock penetration where the bedrock is highly resistive compared to the overlying overburden. In such cases using the pole-dipole or dipole-dipole array very little current actually penetrates the bedrock and the I.P. characteristics observed are those of the overburden only. As was mentioned above, only time domain measurements may be carried out using this array.

There is a special practical advantage to the time domain measurements in areas where it is very difficult to make good ground contact. In such areas the

problem of keeping the primary current rigidly constant, necessary for the frequency domain measurements, becomes severe.

In the time domain, if the primary current varies by as much as 10% during the measurement the absolute error in the chargeability may only be about 5%, which is not significant. This problem is often encountered in very arid areas, e.g. parts of Peru, Chile and other desert regions.

Despite these slight effective differences both methods of I.P. exploration have amply demonstrated their value through important mineral discoveries in many parts of the world. The role of I.P. in mineral exploration is well acknowledged and rapidly expanding.

The writer wishes to thank the various sources of case histories and illustrations cited in the text and in particular, Dr. Keeva Vozoff and Dr. Philip Hallof for valuable contributions.

Bibliography

- Bleil, D. F. (1953)
"Induced Polarization, A Method of Geophysical Prospecting" — *Geophysics*, Vol. 18, pp. 636-661.
- Bodmer, R., Ward, S. H. and Morrison, H. F. (1968)
"On Induced Electrical Polarization and Groundwater", *Geophysics*, Vol. 33, pp. 805-821.
- Dakhnov, B. N. (1941)
"Electrical Well Logging, Interpretation of Electric Logs", Moscow, Chapter IV.
- Dieter, K., Paterson, N. R. and Grant, F. S. (1969)
"I.P. and Resistivity Type Curves for Three Dimensional Bodies", *Geophysics*, Vol. 34, pp. 615-632.
- Hallof, P. G. (1957)
"On the Interpretation of Resistivity and Induced Polarization Results" Doctoral Thesis, M.I.T. Department of Geology and Geophysics.
- Komarov, B.A. (1967)
"Induced Polarization Method". Lecture read at Interregional Seminar of UNO on New Methods for Mineral Exploration with Emphasis on Geophysical Techniques. Moscow, U.S.S.R. July 1967.
- Madden, T. R. et al (1957)
"Background Effects in the Induced Polarization Method of Geophysical Exploration", A.E.C. Report R.M.E. 3150.
- Marshall, D. J., and Madden, T. R. (1959)
"Induced Polarization, a Study of its Causes" — *Geophysics* Vol. XXXIV, pp. 790-816.
- Schlumberger, C. (1920)
"Etude sur la Prospection Electrique du Sous Sol". Gauthier-Villars et Cie. Paris (1920) Chapter 8, (Revised 1930).
- Scott, W. J. and West, G. F. (1969)
"Induced Polarization of Synthetic, High-Resistivity Rocks Containing Disseminated Sulphides" — *Geophysics*, Vol. 34, pp. 87-100.
- Seigel, H. O. (1948)
"Theoretical Treatment of Selected Topics in Electromagnetic Prospecting" — National Research Council of Canada, Unpublished, pp. 34-53.
- Seigel, H. O. (1949)
"Theoretical and Experimental Investigations into the Application of the Phenomenon of Overvoltage to Geophysical Prospecting" Unpublished Doctoral Dissertation, University of Toronto.
- Seigel, H. O. (1959)
"Mathematical Formulation and Type Curves for Induced Polarization" *Geophysics* Vol. XXIV, pp. 547-563.
- Sunde, E. D. (1949)
"Earth Conduction Effects in Transmission Systems" Van Nostrand Co., N.Y. (Monograph)
- Vacquier, V. et al (1957)
"Prospecting for Ground Water by Induced Electrical Polarization" *Geophysics* Vol. 22, pp. 660-687.
- Wagg, D. M. and Seigel, H. O. (1963)
"Induced Polarization in Drill Holes" *Can. Min. Journ.*, April.
- Wait, J. R. (Editor) (1959)
"Overvoltage Research and Geophysical Applications" — Pergamon Press, London, 1959.

Additional copies of this reprint are available from:

Scintrex Limited,
(HEAD OFFICE),
222 Snidercroft Road,
Concord, Ontario, Canada.
Seigel Associates Limited,
750-890 West Pender Street,
Vancouver,
British Columbia.
Seigel Associates Limited,
222 Snidercroft Road,
Concord, Ontario, Canada.
Scintrex Airborne
Geophysics Inc.,
4425-East 31st Street,
Tulsa, Oklahoma, 74135.
Seigel Associates Limited,
115 Moorgate,
London EC2, England.

Seigel Associates
(International) Ltd.,
P.O. Box 627,
39 Duke Street,
Kingston, Jamaica.
Mineral Surveys Inc
(Western Division),
178 West 2950 South,
Salt Lake City,
Utah, 84115.
Seigel Associates
Australasia Pty. Ltd.,
11 King Street, Boulder,
West Australia, 6432.
Seigel Asociados S.A.
de C.V., Av. Hangares
de Aviacion No. 41,
Mexico 9, D.F.



SCINTREX

SOME COMPARATIVE GEOPHYSICAL CASE HISTORIES OF BASE METAL DISCOVERIES

H.O. SEIGEL

Scintrex Ltd. / Seigel Associates Ltd., Toronto, Ont. (Canada)

(Received June 20, 1970)

ABSTRACT

Seigel, H.O., 1971. Some comparative geophysical case histories of base metal discoveries. *Geoexploration*, 9: 81-97.

Base metal ore bodies of exploitable value at current metal prices vary widely in physical properties, dimensions and depth of burial. The mining geophysicist must be alert to the possible range of ore body types and geophysical responses which may be encountered in a given geological environment. Illustrative examples are drawn from actual induced polarization case histories in Canada, Ireland, Mexico, Peru and the U.S.A.

INTRODUCTION

This paper may give support to those who claim that mining geophysics is an inexact science. It is, indeed, inexact when we try to predict the physical properties and, therefore, the geophysical responses of base metal ore bodies. In these days, when nickel sells for \$1.00 per pound and copper for 60 ¢ per pound, most deposits of economic value generally contain less than 5% by volume of conducting sulphides of the ore metals themselves. This leaves us at the mercy of the other 95% by volume of the ore to determine the bulk physical properties. For this reason, we are usually unable to relate a geophysical indication to the valuable metallic content of the causative body.

There is, fortunately, a credit side to the ledger. By using the appropriate geophysical tools, we can, at present, detect almost all base metal ore bodies which are of economic interest within at least the first few hundred feet of the surface. Moreover, as well as detect the presence of these bodies, we can quantitatively determine their location in three dimensions with sufficient accuracy to guide exploratory drilling.

Before initiating his phase of an exploration program, the mining geophysicist must, consciously or otherwise, make a number of decisions, including: What method shall I use? Within a particular method what specific equipment shall be used? If it is an electrical method, what effective frequencies will be used? What will be the line spacing? If it is a ground method, what will be the station interval? If an electrical method, what will be the electrode or coil configuration and what will be the separation between the various elements of the system? If it is an airborne method, what will be the terrain clearance? What will be the profile orientation?

These questions are answered by reference to what is known (or believed to be known) about the search area. In a broad sense it is the geological environment of the area which
Geoexploration, 9 (1971) 81-97

provides the nature of the deposits to be anticipated, e.g., in Precambrian rocks one expects massive sulphide deposits containing copper and zinc to occur in Archaean volcanics; massive and disseminated sulphide deposits containing copper-zinc and lead in Proterozoic sediments, and massive to disseminated sulphide deposits containing nickel associated with basic igneous intrusives; in carbonate sediments of Paleozoic age one expects lead-zinc deposits, or contact metamorphic copper, iron, lead and zinc deposits, depending on the structural conditions, etc.

The justification for the execution of an exploration program is usually the expectation of the existence of a certain type or types of deposits. The geophysical phase of the program is, therefore, guided in its conception and execution by the appropriate expectation. Equally significant, it may be said to be biased by that expectation. Some bias is necessary as the exploration program must be conducted on the premise that once a particular type of ore deposit has been discovered in an area a repetition of such a deposit is more probable than is the occurrence of a deposit of a type hitherto unknown to that area. The geophysicist, therefore, sets his sights or "calibrates his tools" with reference to the known or the anticipated deposit in the area and then initiates his program.

As the exploration program progresses and greater knowledge is gained about the area, its geology and its mineral deposits, one frequently finds cause to change the exploration parameters. Vein type deposits may be found where only concordant mantos were expected; large, low-grade disseminated deposits may be found where only smaller, massive, high-grade deposits were expected, or vice versa. The change of geophysical orientation necessitated by the experience in the area often expresses itself in a change of line spacing or depth of detection and, in the extreme, in a change of geophysical method or the use of two different reconnaissance methods.

The present paper illustrates the range of geophysical responses which may arise from proven or potential base metal ore deposits using only one method, that of induced polarization - IP. The illustrations are gathered from case histories of large porphyry copper deposit smaller and higher grade copper deposits in intrusive rocks; contact metamorphic copper deposits; lead-zinc and copper deposits in carbonate rocks. The deposits in question vary not only in size, depth of burial and sulphide content but also in the ratio of ore metal/total sulphur.

For convenience in comparison, all of the cases selected for illustration have employed the time-domain induced polarization method, simply because the writer has a great selection of such material. As this information was obtained at various times over a period of twenty years the actual field techniques and instrumentation may vary somewhat from case to case. An attempt will be made, however, near the end of the paper to normalize the induced polarization responses to their equivalents using a standard technique.

A goodly number of examples used are from actual discovery case histories, from the files of our organization, including Lornex, Alwin, Gortdrum, Silvermines, Pyramid and Coronet. In two other instances (Cuajone and San Manuel) the IP work was carried out after the actual discovery but sufficiently early to guide the development drilling. These latter two examples were obtained from work carried out by Newmont Exploration Limited.

PORPHYRY COPPER DEPOSITS

Cuajone deposit, Peru (R.W. Baldwin in Wait, 1959)

A large, good grade porphyry copper deposit is currently under active development in southern Peru. It consists of over 450 million tons of ore averaging 0.98% Cu, in quartz monzonite porphyry largely overlain by a capping of Late Tertiary volcanics. As guidance to the program of drilling through this capping the first induced polarization survey in South America was carried out in 1952. The current cycle used was 3 sec on and off and the transient voltage was integrated over a 1-sec period following the current interruption.

Fig.1 shows the results of a typical expanding depth determination over this ore body using the Wenner array. The quantitative interpretation of this data suggests an upper layer (Tertiary volcanics) 100 m thick of resistivity 50 ohm-m and chargeability 7 msec overlying a lower layer (mineralized porphyry) of about 200 ohm-m resistivity and 46 msec chargeability. The actual sulphide content observed by drilling in this area was about 3% by volume, of which about 2% is chalcopyrite.

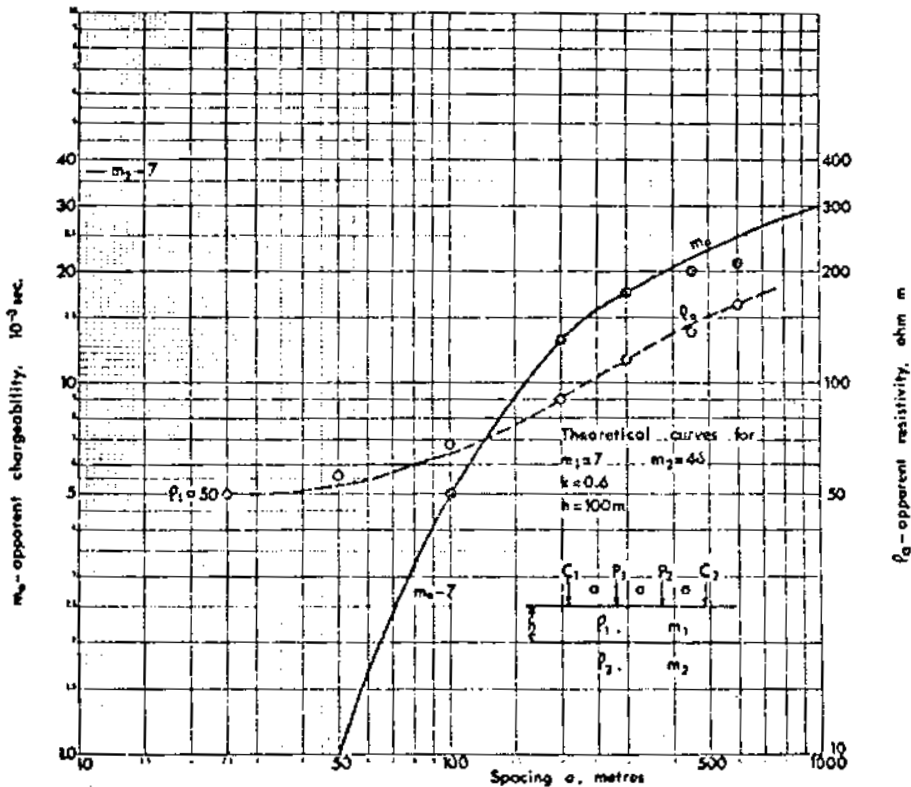

Fig.1. Expanding depth determination, Cuajone porphyry copper deposit, Peru.

Reference will be made later to the significance of the absolute value of the mineralization chargeability. It may be noted at this time, however, that the resistivity of the mineralized porphyry is 200 ohm-m, a relatively high figure and four times higher than that of the overlying Tertiary volcanics.

San Manuel deposit, Arizona, U.S.A. (Seigel, 1962)

Fig.2 shows the results of an expanding depth determination over a portion of the San Manuel porphyry copper deposit, Arizona, using a Wenner array, a charging time of 30 sec and an integration time of 3 sec. The geological environment consists of mineralized quartz monzonite porphyry overlain by Tertiary Gila conglomerate. The San Manuel deposit (at that time) consisted of over 500 million tons of ore averaging about 0.78% Cu and some molybdenite. The total sulphide content is of the order of about 6-10% by volume of which about 1.5% is chalcopyrite and the remainder largely pyrite.

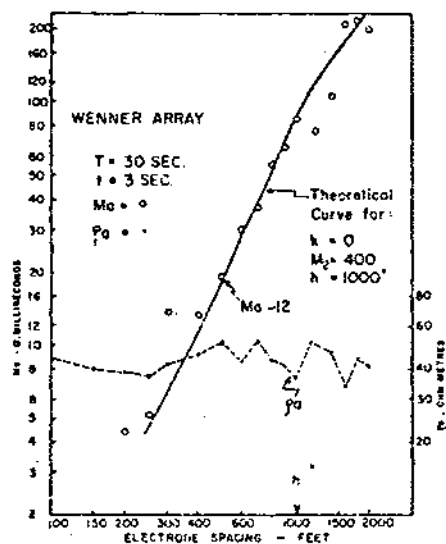

Fig.2. Expanding depth determination, San Manuel porphyry copper deposit, Arizona, U.S.A.

The observed resistivity varies little from 40 ohm-m, regardless of electrode spacing (i.e., depth). Thus the Gila conglomerate has essentially the same resistivity as the mineralized intrusive it overlies. The chargeability increases progressively with spacing, however, and quantitative interpretation indicates an interface at about 1,000 ft. with low chargeability (12 msec, Gila conglomerate) above and much higher chargeability (400 msec) mineralized quartz porphyry below. The actual depth to the upper surface of the sulphide body, as indicated by later drilling, was 1,100 ft.

Lornex deposit, British Columbia, Canada (Seigel, 1970)

The Lornex porphyry copper deposit, currently being brought into production in the Highland Valley area, British Columbia, Canada, is estimated to contain of the order of 300 million tons of ore grading 0.43% Cu and 0.04% Mo. The total sulphide content is rather low, being about 2–3% by volume of which about 1% is, therefore, chalcocopyrite and the remainder pyrite.

Fig.3 shows one of the discovery geophysical sections over this body. The current cycle was 1.5 sec on-time and 0.5 sec off-time and integration-time. The total sulphide content and copper grade increase somewhat, as well as the thickness of overburden, as one progresses west along the traverse to about 9,000 E. The ore lies in Skeena quartz diorite.

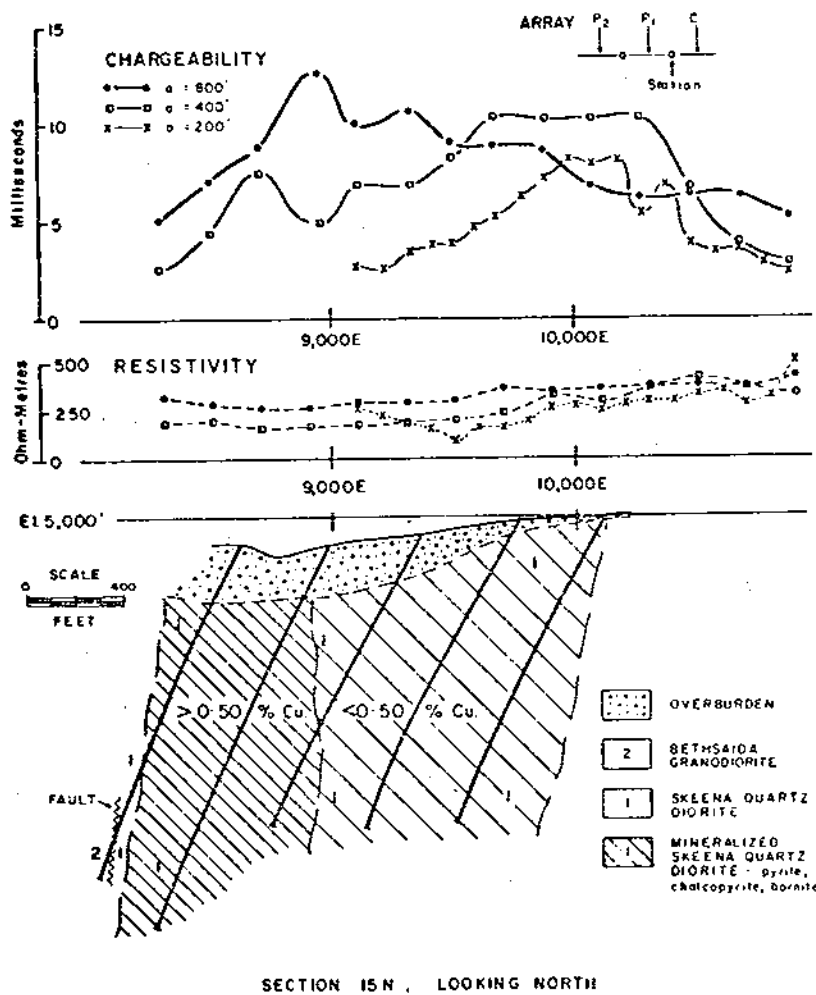

Fig.3. Geophysical and geological section, Lornex porphyry copper deposit, British Columbia, Canada.

At about 9,000 E the interpretation of the three spacing information gives a two layer equivalent of 170 ft. of overburden of resistivity about 65 ohm-m and chargeability about 0.5 msec, overlying bedrock of about 550 ohm-m resistivity and 23 msec chargeability. The relatively high order of resistivity of the ore is not too surprising in view of the low total sulphide content of the ore.

Mariquita Property, Sonora, Mexico

Although no commercially exploitable ore body has as yet been proven, the geophysical results shown in Fig.4 are of interest in illustrating the detection of a large zone of previously unknown disseminated sulphide mineralization under 300 m of alluvium

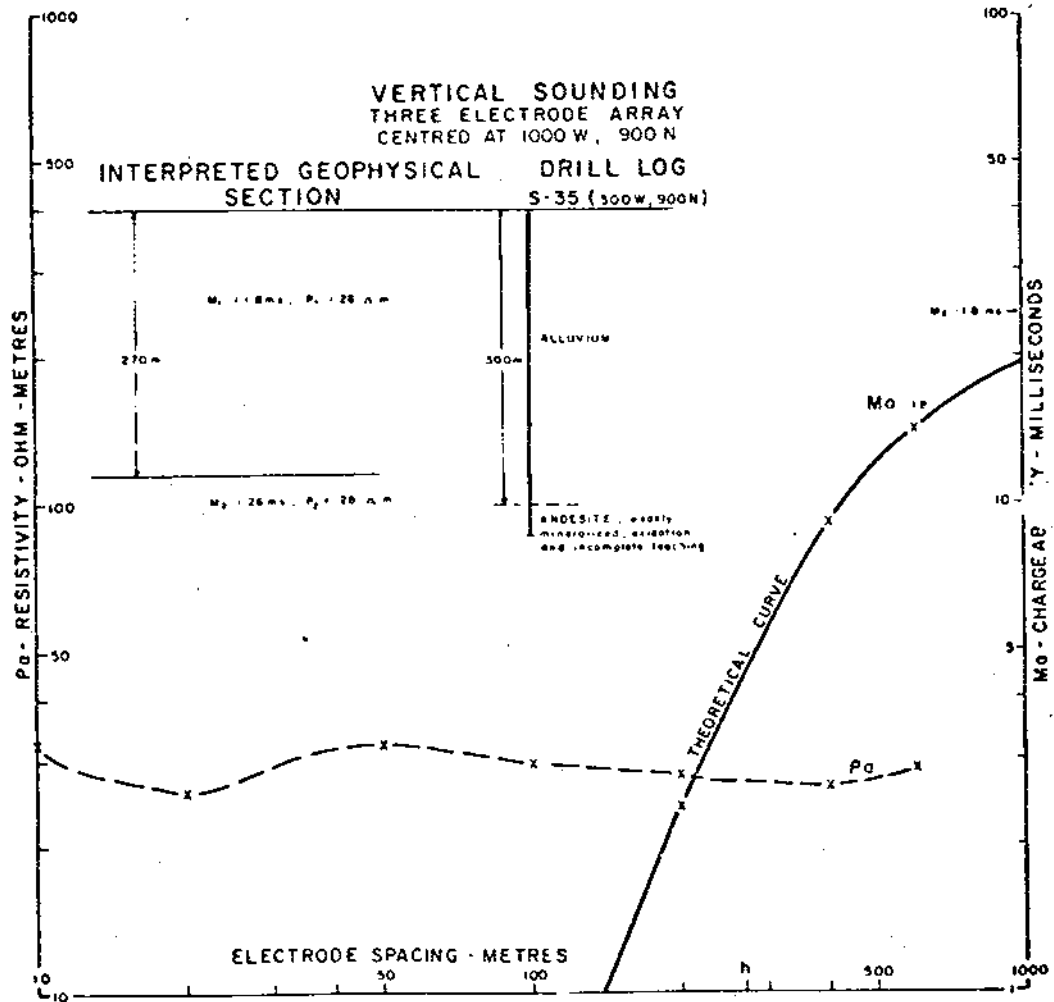

Fig.4. Expanding depth determination, Mariquita area, Sonora, Mexico.

in Sonora, Mexico. The alluvium and mineralized andesite bedrock have low and nearly identical resistivities (28 ohm-m). On the same program and area the IP method has detected sulphides, later proven by drilling, at a depth of 463 m (1,500 ft.) to its upper surface.

The great thickness of alluvium in this area was wholly unexpected and initially, electrode spacings of 200 m or less were employed, which are patently too small for the actual thickness. This example also illustrates the ability of the IP method to detect sulphide mineralization at considerable depth in a low resistivity environment.

SMALLER HIGHER-GRADE COPPER DEPOSITS

Alwin deposit, British Columbia, Canada

This deposit is a small one consisting of about 1 million tons averaging about 2.5% Cu, mostly chalcopyrite with some bornite and an equal amount of pyrite (6-7% total sulphides) in a steeply dipping fracture zone in the Guichon batholith. The geologic environment is similar to that of the Lornex deposit which lies in the same intrusive complex. The mineralized zone is relatively narrow, being less than 50 ft. on some sections.

Fig.5 shows a geophysical section across this deposit. The most striking feature of this section is that the 400 ft. reconnaissance electrode spacing, commonly employed as a minimum spacing for porphyry copper exploration in this area, gave no significant anomalous response over this deposit. Had shorter spacing not been carried out the mineralized zone would not have responded at all. In this case the porphyry copper approach completely failed to reveal the presence of a small but worthwhile body of higher grade close to surface.

The intrinsic physical properties of the mineralized zone on this section are less than 250 ohm-m for resistivity and more than 10 msec chargeability. The current cycle employed was 1.5 sec on-time and 0.5 sec off-time.

Gortdrum deposit, Ireland (Seigel, 1965)

In the search for lead-zinc deposits in carbonate rocks of Carboniferous age in Ireland, the Gortdrum deposit was found in 1963. Its geological environment is quite similar to that of the two major lead-zinc deposits previously discovered in Ireland, occurring as it does in dolomitic limestones near a fault contact with Devonian Old Red Sandstones. The mineralogy is quite different, however. The deposit, which is in active production, had originally estimated reserves of 4.2 million tons averaging 1.19% Cu, 0.75% oz. Ag and, more recently, was found to contain significant amounts of mercury.

The predominant mineralization is finely disseminated chalcocite and bornite, with tetrahedrite, some chalcopyrite and very little other sulphides. The total sulphide content does not exceed 3% by volume. The mineralization is somewhat erratically distributed but, in general, increases as one approaches the fault. In gross it dips with the fault, which is almost at right angles to the dip of the Carboniferous sediments.

Geocexploration, 9 (1971) 81-97

RESISTIVITY

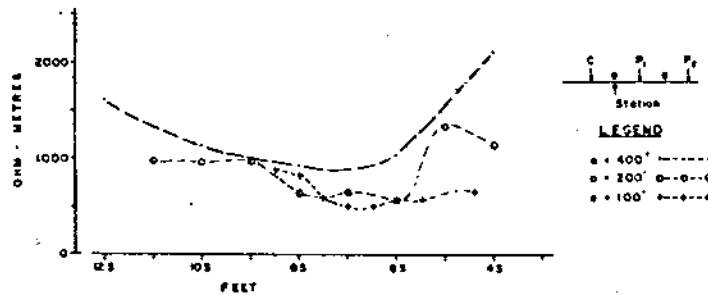

CHARGEABILITY

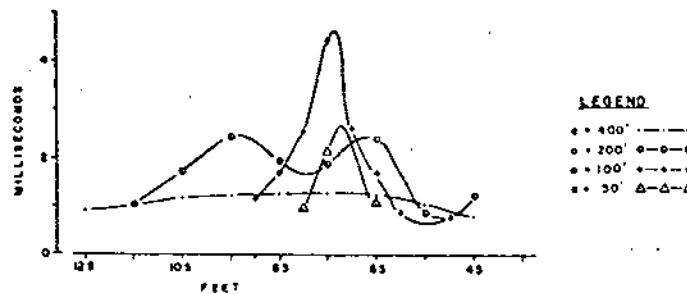

GEOLOGIC SECTION

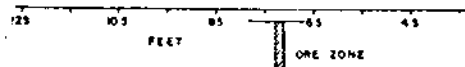

Fig.5. Geophysical and geological section, Alwyn copper deposit, British Columbia, Canada.

Fig.6 shows a typical discovery geophysical section across this deposit. The IP technique employed herein had a 1.5-sec current on-time and 0.5-sec current off and transient integration-time. Points of interest on these results include:

- (a) The ore body has an intrinsic gross chargeability in excess of 20 msec and a resistivity of the order of 500 ohm-m.
- (b) The markedly lower resistivity on the south side of the traverse reflects, in part, the fault itself and, in part, the lower resistivity sandstone.
- (c) The chargeability curve shape indicates a steep northward dip, causing a difference of opinion between the geologist and the geophysicist which was only resolved after six holes had first been drilled with the dip of the deposit.
- (d) The intrinsic mineralization chargeability response, although it is many times the non-metallic background level and relates well to the total sulphide content, is low in relation to the copper content because of the high copper/sulphur ratio.

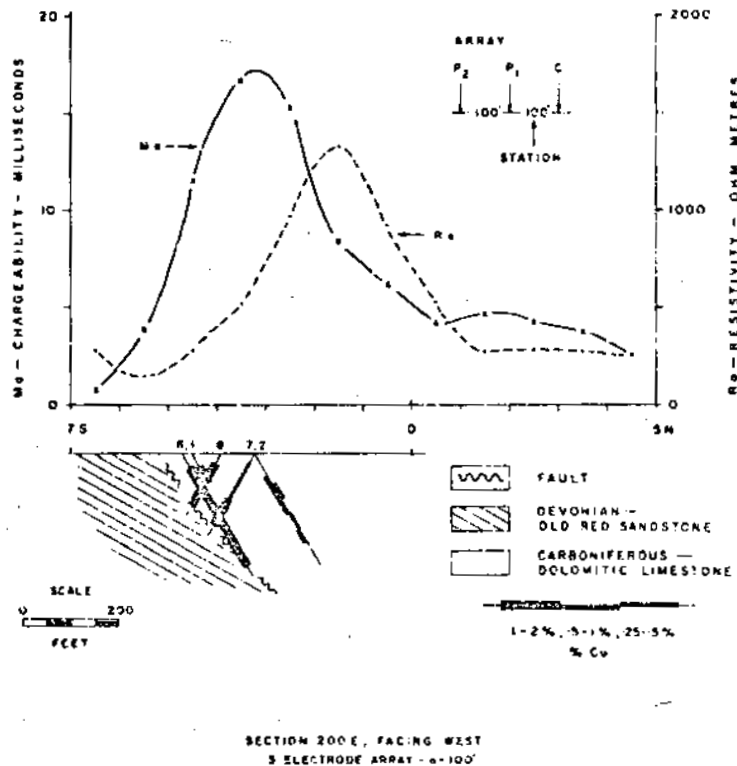

Fig.6. Geophysical and geological section, Gortdrum copper deposit, Ireland.

Craigmont deposit, Highland Valley area, British Columbia, Canada, (Seigel, 1962)

Close to the margin of the same Guichon batholith associated with the Lornex and Alwin deposits lies a large contact metamorphic copper deposit which is being actively exploited by Craigmont Mines Ltd. It consists of about 15% by weight of specularite and magnetite, plus about 5% by weight of chalcopyrite and pyrite. It occurs in lime-rich beds of the Nicola Series, near the Guichon batholith contact. The deposit contains in excess of 21 million tons averaging about 1.8% Cu.

Fig.7 shows some geophysical results, including chargeability, resistivity and vertical magnetic intensity across the body. The IP current wave form was 1.5 sec on-time and 0.5 sec off-time. The body was initially investigated because of its associated magnetic anomaly which rises to 6,000 γ peak relief on this section.

Points to be noted in respect of Fig.7 include:

(a) The intrinsic chargeability of this body is in excess of 15 msec, versus a background of about 2 msec. Whereas a legitimate question might be raised as to the contribution of the specularite and magnetite the observed IP response, as we shall see later, the total sulphide content of the ore in this body is quite adequate to account for the entire

response. A reasonable conclusion, therefore, is that the iron oxides here do not appreciably respond to the IP method.

A coincident IP and strong magnetic anomaly need therefore, not necessarily imply the presence of iron oxides alone.

(b) The resistivity of the ore zone is of the order of 200 ohm-m, exceeding by almost 100% that of the rocks (and soil) of the immediate vicinity. The iron oxides are apparently relatively poorly conducting in this body.

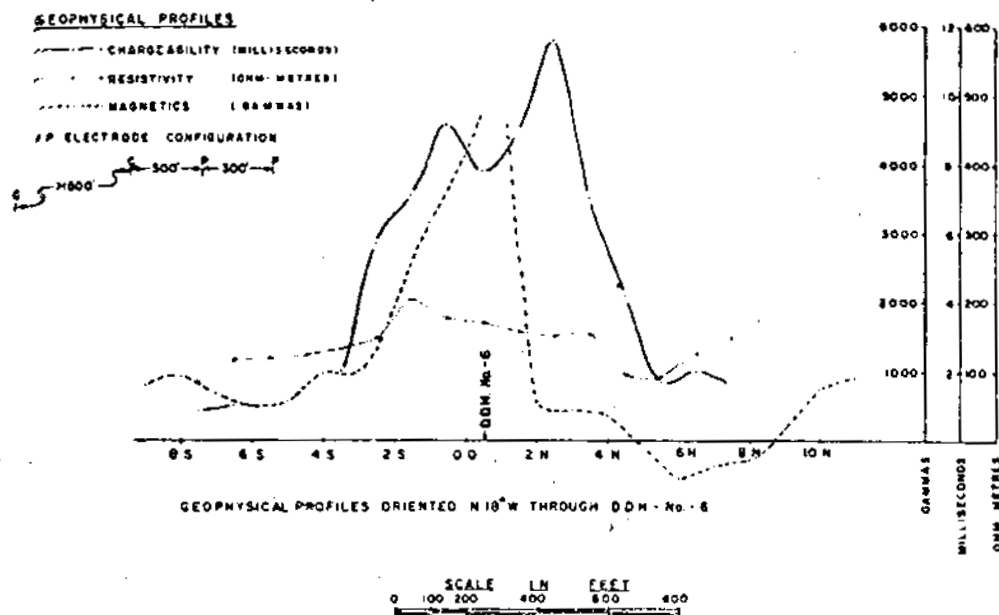

Fig.7. Geophysical section, Craigmont copper deposit, British Columbia, Canada.

New West Amulet deposit, Noranda area, Quebec, Canada (Seigel, 1962)

As an example of an ore grade but highly resistive copper deposit, we have that of New West Amulet Mines, in the Noranda area, Quebec. The Noranda area is characterized by highly conducting "massive" sulphide bodies containing pyrite, pyrrhotite, chalcopyrite and sphalerite. Electromagnetic induction prospecting is the traditional geophysical reconnaissance method in this area.

Fig.8 shows a geophysical traverse across this body with IP and resistivity. The IP current wave form was 1.5 sec on-time and 0.5 sec off-time. Despite the fact that the body contains about 6% by volume of pyrite and chalcopyrite (2% Cu) in rhyolites, the lowest resistivity observed in the mineralized area is about 4,000 ohm-m. Turam, horizontal and vertical loop E.M. tests over this body have yielded no significant response, confirming the non-conducting nature of this body.

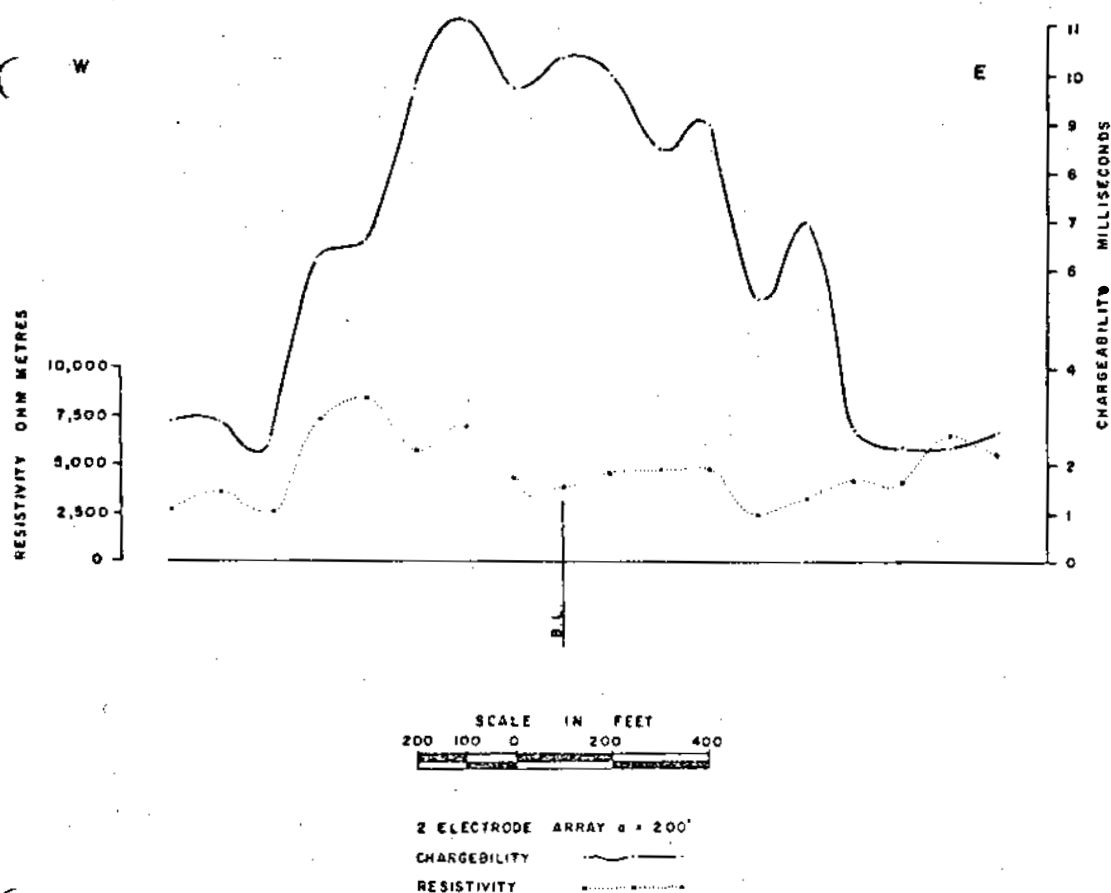

Fig.8. Geophysical section, New West Amulet copper deposit, Quebec, Canada.

The observed chargeability level over the body rises to a peak of 11 msec from a background level of about 2 msec. This response is low with respect to the total sulphide content by a factor of almost 4. An explanation for both the very high resistivity and relatively low (although clearly indicated) IP response is possibly that the deposit is highly silicified and of exceedingly low porosity so that only about 25% of the sulphide grains are able to participate in the bulk electrical conduction.

STRATA-BOUND LEAD-ZINC DEPOSITS

Mogul Mines deposit, Co. Tipperary, Ireland (Seigel, 1965)

Fig.9 shows a typical geophysical-geological section across the "Silvermines" lead-zinc deposit of Mogul Mines Ltd., in Co. Tipperary, Ireland. The deposit is similar to the Gortdrum

Geoexploration, 9 (1971) 81-97

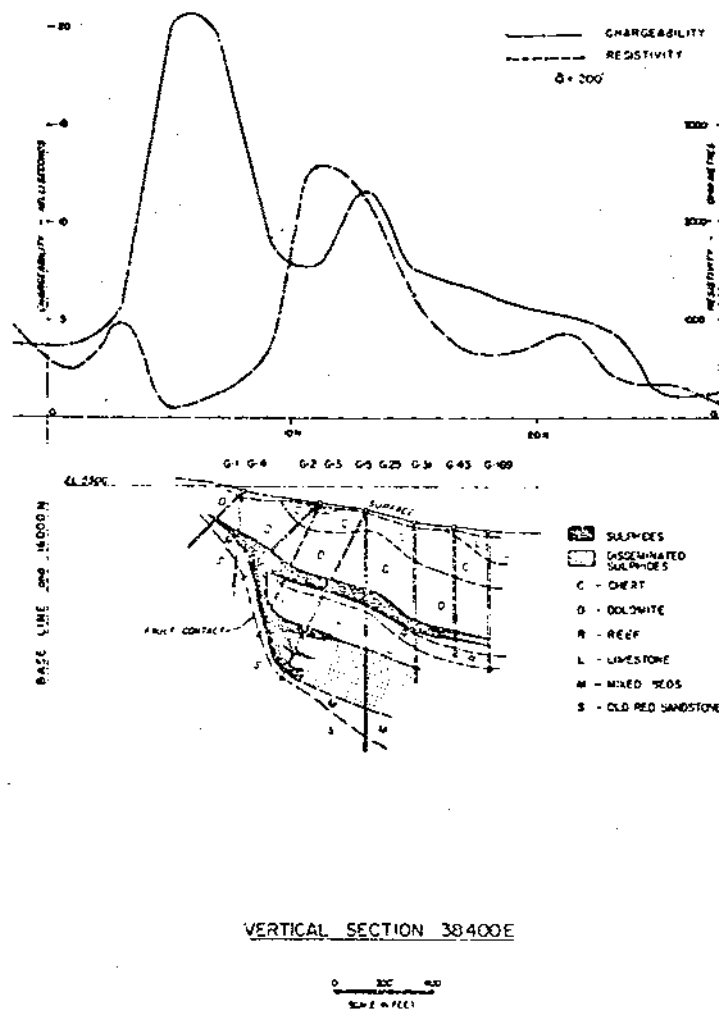

Fig.9. Geophysical and geological section, Mogul Mines lead-zinc deposit, Co. Tipperary, Ireland.

copper-silver deposit (above) and the Tynagh lead-zinc deposit of Northgate Mines, Limited, all lying in Lower Carboniferous limestones near a fault contact with Devonian sandstones. The mineralogy of the Silvermines deposit differs from that of the other deposits in a variety of ways, including the presence in it of a considerable pyrite content, rendering the body highly conducting. The body has been shown to respond to standard induction electromagnetic techniques, although it was the IP data which provided the guidance for the discovery and development drilling program.

Two or more separate ore zones have been drilled to date, of which the one shown on Fig.9 consists of 11 million tons, averaging 2.8% Pb, 8.2 % Zn and 0.8 oz. Ag.

The geophysical response of this body is typical of that from a body of well-interconnected conducting sulphides. The maximum observed chargeability is about 20 msec and the minimum observed resistivity is of the order of 80 ohm-m, both being anomalous to the

extent of at least a factor of 10 from the physical properties of the surrounding limestones and sandstones.

Pyramid deposit, Northwest Territories, Canada (Seigel, 1968)

The larger of the two lead-zinc deposits of Pyramid Mines Ltd., in the Pine Point district, Northwest Territories, Canada, consists of about 10 million tons grading 12.0% combined lead-zinc. It is a typical strata-bound manto lying in reefoidal dolomites of Devonian age. In order of decreasing abundance the mineralization consists of sphalerite, marcasite, and galena.

Fig.10 shows a geophysical-geological section across this body. A very clear chargeability

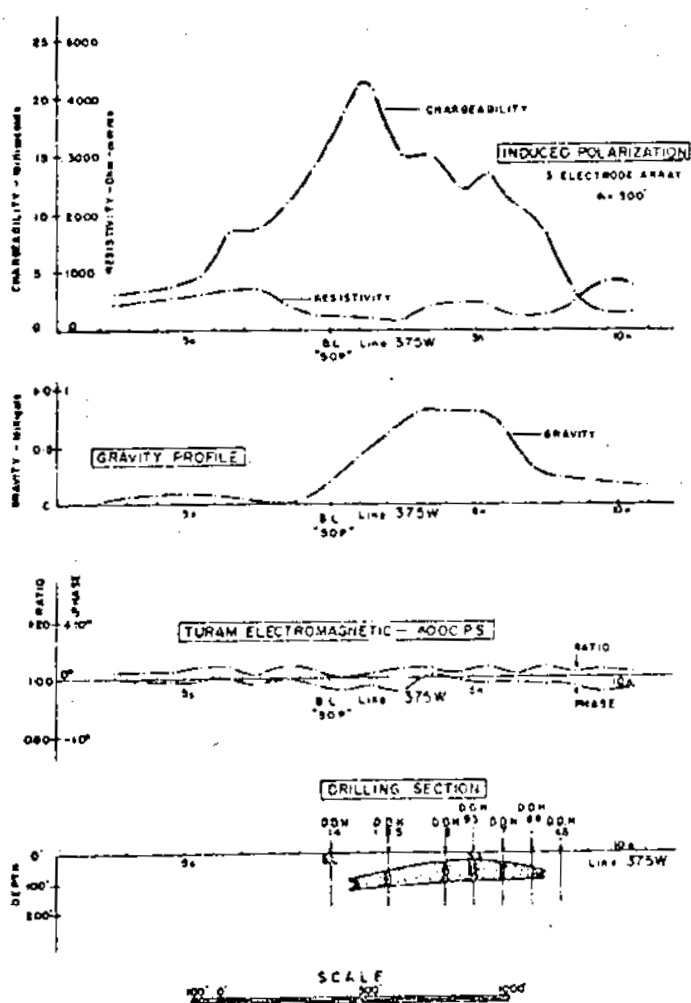

Fig.10. Geophysical and geological section, Pyramid Mines lead-zinc deposit, Northwest Territories, Canada.

indication has been obtained of this body, rising to 22 msec as against a very low regional background level of 1–2 msec (1.5-sec current on-time and 0.5-sec current off-time). The intrinsic bulk chargeability of this body is estimated to be of the order of 25 msec.

There is a coincident resistivity depression, dropping to as little as 100 ohm-m, from a regional level of about 400–800 ohm-m. Unfortunately for the economics of exploration in this area, the intrinsic bulk conductivity of the body is still too low to give an appreciable electromagnetic induction response, as the Turam profile below will show.

The gravity traverse shows about 0.8 mgals positive relief over this body and gave more definitive guidance to the drilling program than the IP data, as the gravity reflects the disposition of all the sulphide mineralization including sphalerite, the most abundant sulphide.

Whereas good representative figures for the average conducting sulphide content (marcasite and galena) for this deposit are lacking, it is estimated that a total of about 5–10% by volume is reasonable.

Coronet deposit, Northwest Territories, Canada

This example is selected to illustrate the range of responses to be expected even within a single type of deposit and geologic environment. The geological environment and grade are very similar to that of the Pyramid case above, but the body size is only about 750,000 tons and the marcasite content is much lower, being almost negligible. At today's metal prices and in view of its convenient location and shallow depth this body is still of economic interest.

Fig. 11 shows a composite geophysical–geological section across this body. There was a detectable IP response, of 2 msec amplitude, which was discernible only because the regional chargeability level is extremely low (1 msec or less). There are at best, minor resistivity and gravity indications on this body.

The intrinsic body chargeability is probably of the order of 5 msec and its total conducting sulphide content probably averages less than 2% by volume.

SUMMARY

The eleven examples have been deliberately selected for this paper because of their diversity of size, shape, depth of burial and sulphide content. With one or two exceptions, they are economically exploitable bodies, despite these variations in physical parameters.

In considering the response of these bodies to the IP and resistivity methods the one common denominator is the fact that all the bodies are detectable by the IP method. The resistivity contrast is, as often as not, the reverse of what might have been anticipated, i.e., higher resistivity in the ore body than in the overlying or adjacent formations. For the same amount of conducting sulphides (up to 10% by volume, at least) the observed resistivity may lie anywhere between 30 and 3,000 ohm-m, depending on the nature of the host rock. For such amounts of conducting sulphides the chargeability appears to bear a more consistent relationship to the volume sulphide content.

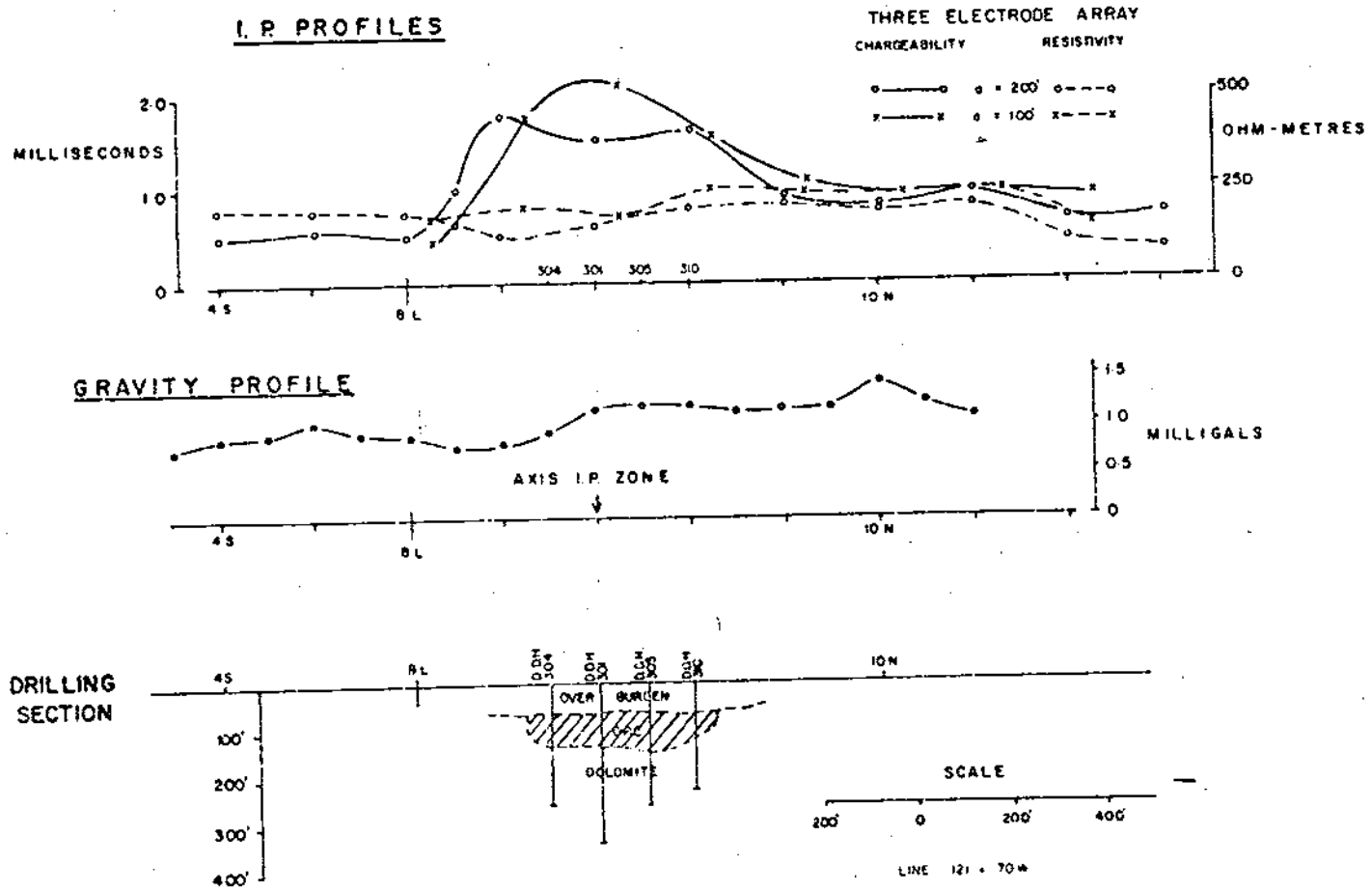

Fig.11. Geophysical and geological section, Coronet Mines lead-zinc deposit, Northwest Territories, Canada.

Table I summarizes the relationship between the excess chargeability and volume percentage of conducting sulphides for a number of the cases. All chargeabilities have been normalized to their equivalent values as though techniques equivalent to that of the first case history (Cuajone) had been used. At present, a different current cycle is employed in the Scintrex time-domain IP equipment (2 sec on and off-time) but the calibration of the instrument has automatically been set to give effective chargeabilities comparable to that of the Cuajone wave form.

Whereas Table I shows a considerable variation in normalized chargeability per percentage sulphide, the uncertainty in total conducting sulphide content can be responsible for much of this spread. In any event, a response of 10 msec per percent sulphides by volume would almost always yield estimates of sulphide content which are accurate to within a factor of two for conducting sulphide content to about 10%. For much higher concentrations these estimates would be on the low side.

TABLE I

Comparative physical properties

Ore deposit	Normalized excess chargeability (msec)	Ore zone resistivity (ohm-m)	Combined conducting sulphide content (% by volume)	Excess normalized chargeability/% sulphides by volume (msec)	MF/ % x 1,000 ¹
Cuajone	40	200	2-4	10-20	50-100
San Manuel	105	40	6-10	10-17	250-430
Lornex	40	550	2-3	13-20	26-40
Gortdrum	40	500	2-3	13-20	26-40
Craigmont	25	200	3	8	40
New West					
Amulet	16	4,000	6	3	0.75
Pyramid	35	50	5-10	3.5-7	70-140
Coronet	10	75	2	5	60

¹The "metal factor" equivalent, i.e., the ratio of the chargeability per percent sulphides divided by the corresponding resistivity, x 1,000 for convenience.

CONCLUSIONS

The present examples lead to a number of conclusions, which may be presented as follows:

(1) It is clearly futile to estimate the grade, in terms of metal content, of a sulphide body which is known from its IP response only, as the metal-sulphur content is commonly unpredictable, even in one mining area.

(2) There is a danger in using a reconnaissance geophysical technique designed only for a specific type of target. Ideally, reconnaissance techniques, where possible, should permit the detection of small bodies near surface and larger bodies at greater depths. This may be accomplished through the use of multiple element spacings or using fixed source methods... e.g., gradient array in IP or Turam in E.M., which have no clearly defined depth limitation.

(3) One cannot be dogmatic about the physical properties necessary for a base metal deposit to be of economic interest.

(4) In the case of the induced polarization method, the intrinsic chargeability or P.F.E. of a deposit is reasonably proportional to the volume percentage of total conducting sulphide content. For the time-domain IP equipment we currently employ, this factor is about 10 msec per percent by volume of such conducting sulphides. Conversely, in rocks with low-normal chargeability background (e.g., most acid porphyries) a uniform dissemination of as little as 1/4% sulphides by volume would be detectable.

(5) The ratio of chargeability to resistivity (i.e., metal factor) per percent by volume conducting sulphides is much more variable than the chargeability or P.F.E. and should not be employed to obtain an estimate of this percentage, at least for deposits containing 10% or less of conducting sulphides. This is so because the resistivity factor is far more variable than the chargeability per percent sulphides by volume.

REFERENCES

- Seigel, H.O., 1962. Induced polarization and its role in mineral exploration. *Trans. Can. Inst. Mining Met.*, 65: 157-158.
- Seigel, H.O., 1965. Three recent Irish discovery case histories using pulse-type induced polarization. *Trans. Can. Inst. Mining Met.*, 68: 343-348.
- Seigel, H.O., 1968. Discovery case history of the Pyramid Ore Bodies, Pine Point, Northwest Territories, Canada. *Geophysics*, 33(4): 645-656.
- Seigel, H.O., 1970. The induced polarization method. In: *Mining and Groundwater Geophysics, 1967-Geol. Surv. Can. Rept.*, 26: 123-137.
- Wait, J.R., 1959. *Overvoltage Research and Geophysical Applications*. Pergamon Press, London.

N

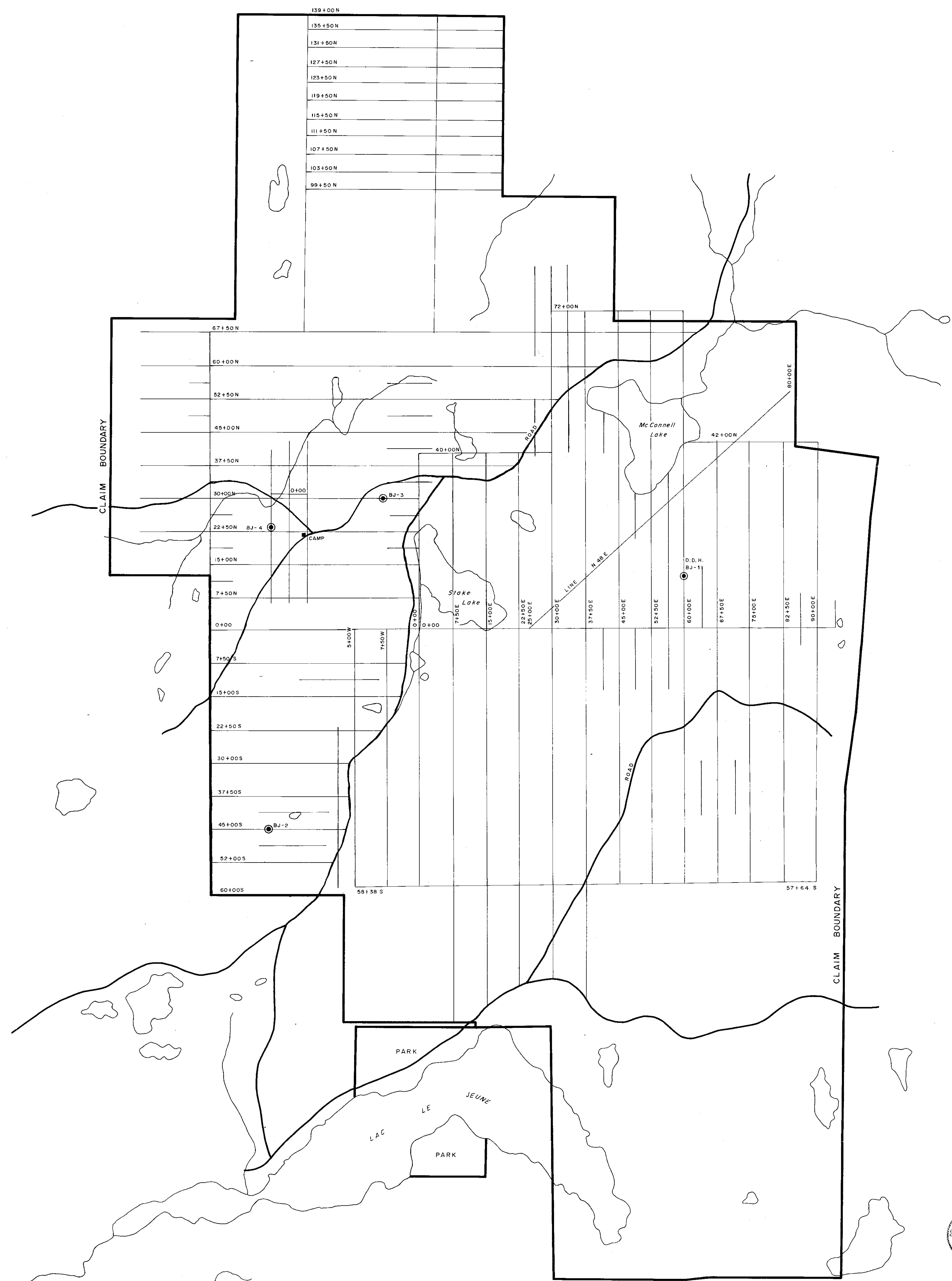

Department of
Mines and Petroleum Resources
ASSESSMENT REPORT
3892 MAP #2

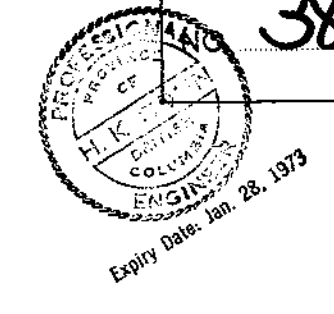

3892 M-2

REVISIONS Date By	CANADIAN JOHNS MANVILLE CO. LTD. KAMLOOPS B.C.	
	C. J. M. PROJECT 410 LAC LE JEUNE CLAIM BOUNDARY AND GRID LOCATION	
Technical Work By Versatile Mining Services Ltd.	Scale 1" = 1000' Date April 1971	PROJECT 187
Drawn By T. G. Valjeon Approved By J. R. Kerr	Drawing Number 410	

L22+50N 4W 0 4E 8E 12E 16E 20E 24E

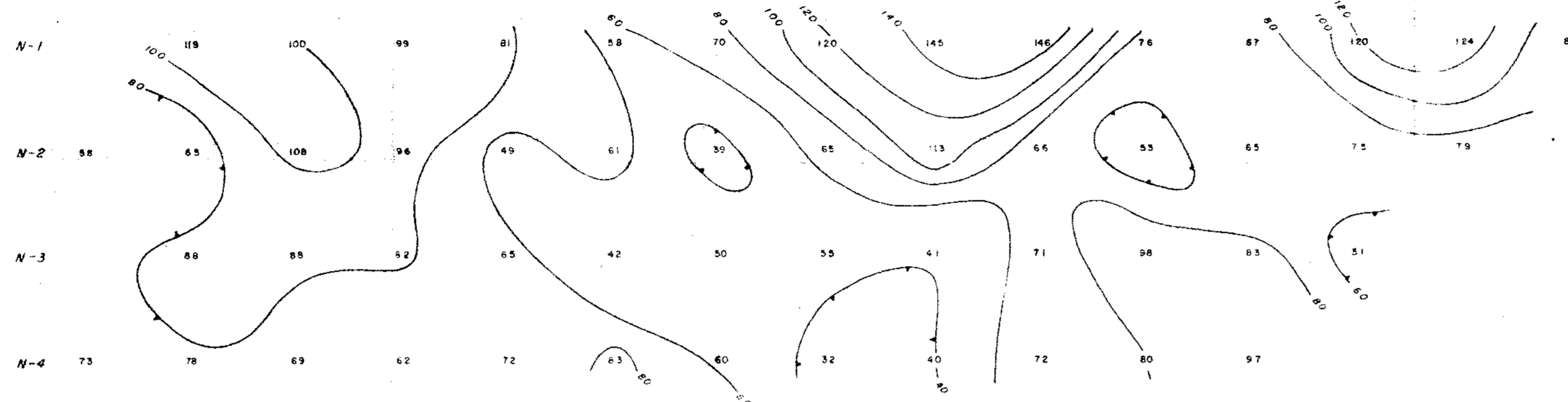

RESISTIVITY

L22+50N 4W 0 4E 8E 12E 16E 20E 24E

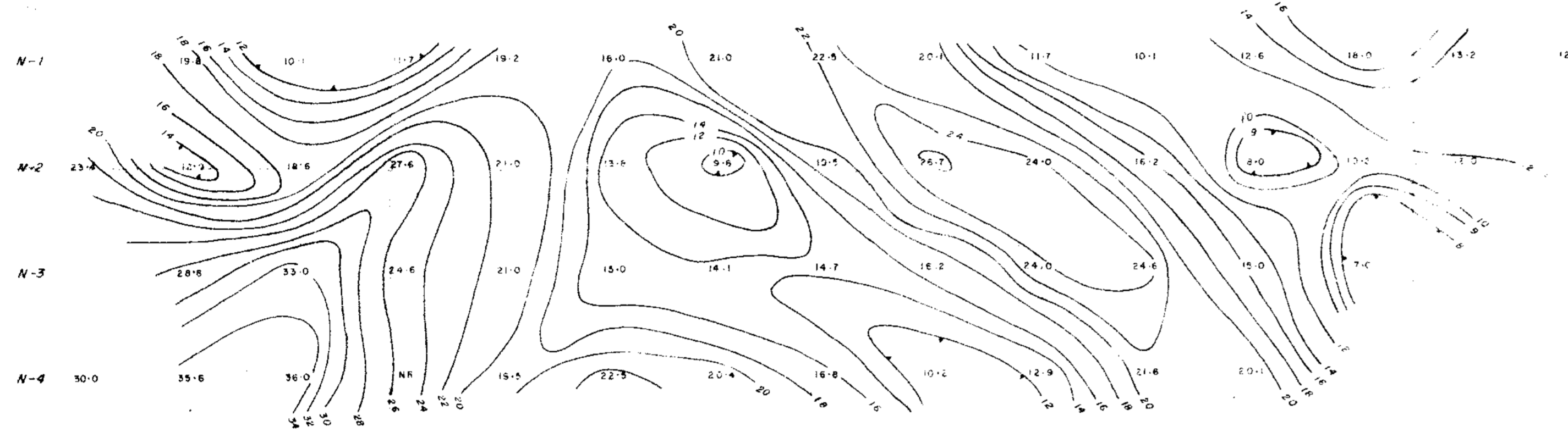

CHARGEABILITY

L48+00E 8N 12N 16N 20N 24N 28N 32N 36N 40N 44N 48N 52N 56N 60N 64N 68N 72N

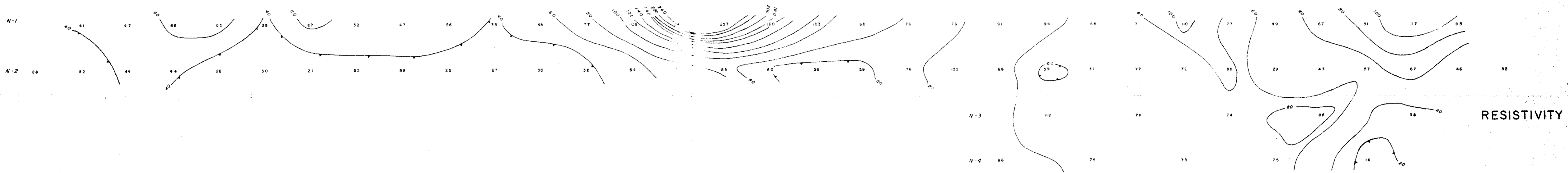

RESISTIVITY

L48+00E 8N 12N 16N 20N 24N 28N 32N 36N 40N 44N 48N 52N 56N 60N 64N 68N 72N

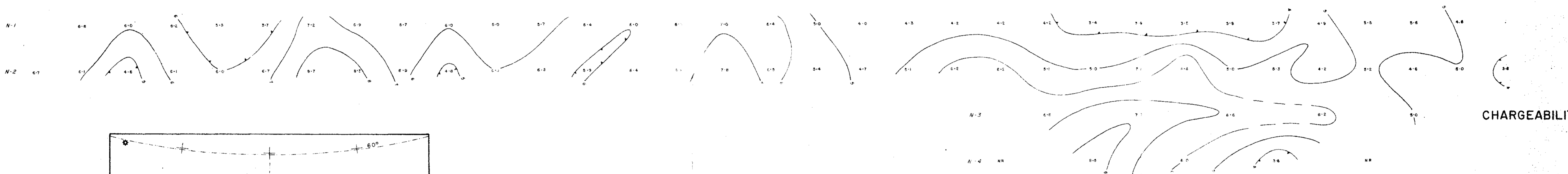

CHARGEABILITY

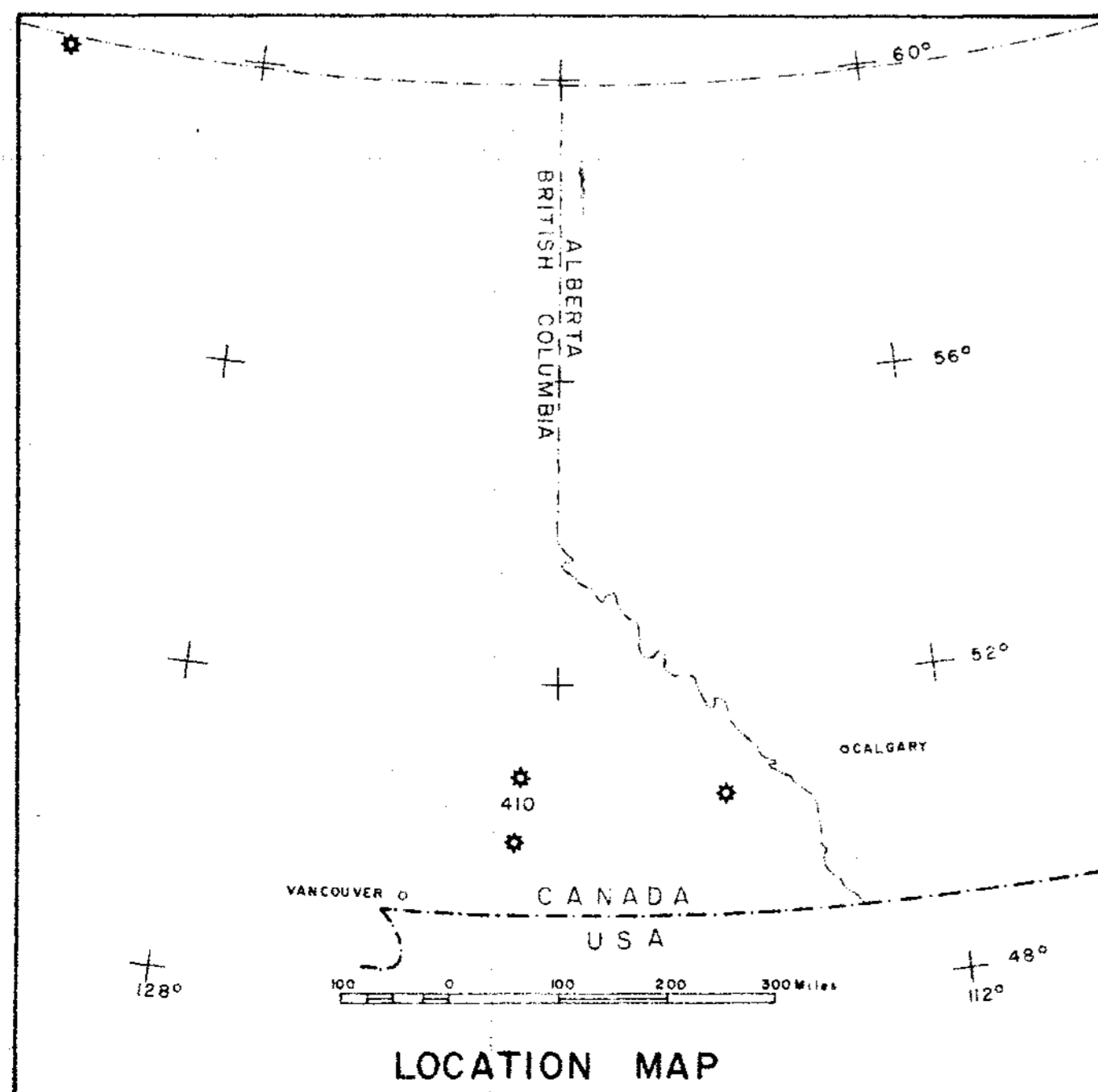

LOCATION MAP

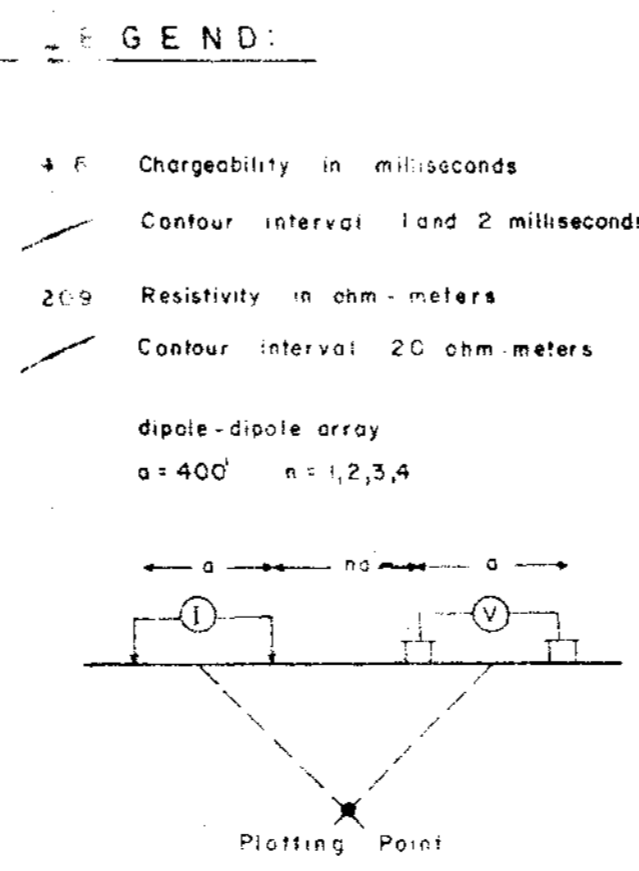

3892 #6

PLATE 4

CANADIAN JOHNS-MANVILLE Co. LIMITED

PROJECT 410
L AND R ROAD GRID
INDUCED POLARIZATION SURVEY

SCALE: 1" = 200'
SURVEY BY SEIGEL ASSOCIATES LIMITED

MAY-AUG 1971



L 7+50E

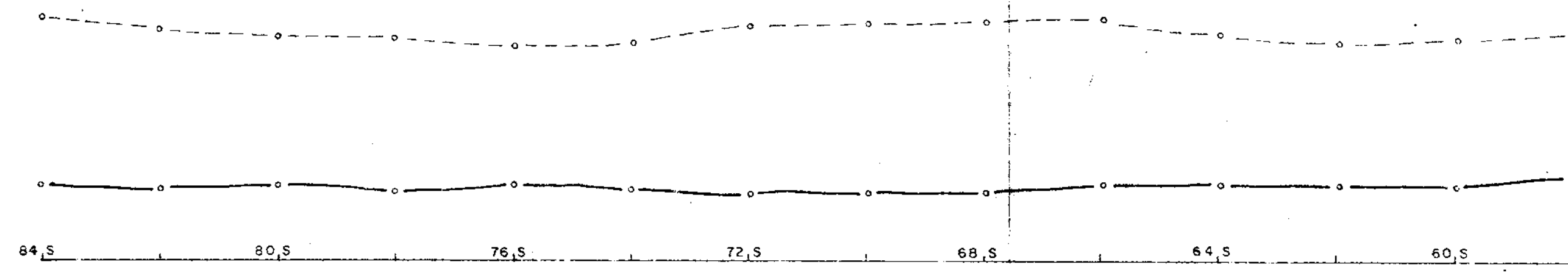

L 15+00E

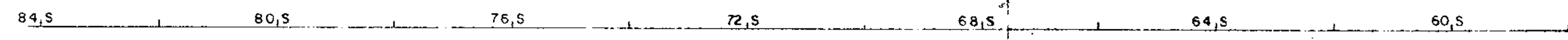

L 22+50E

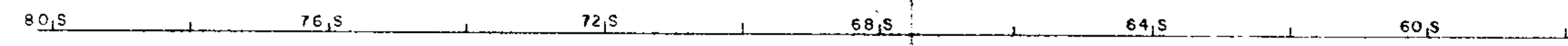

L 30+00E

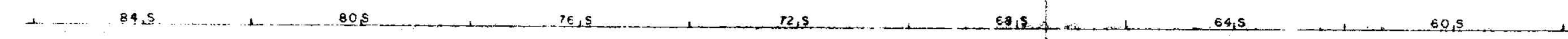

L 37+50E

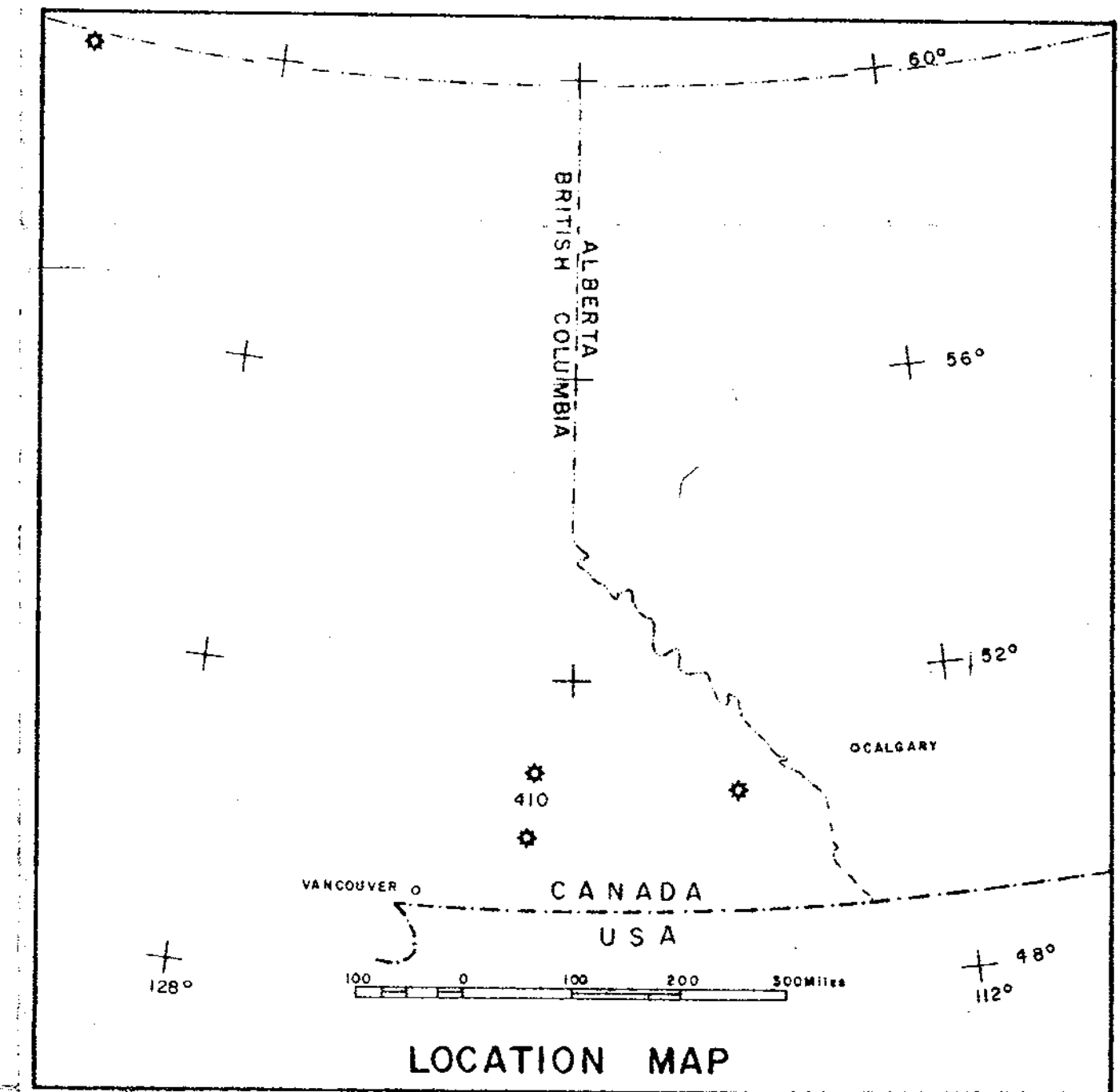
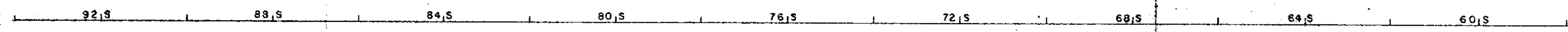

LEGEND:

- CHARGEABILITY a = 400' 1" = 10 milliseconds
- - -○- RESISTIVITY a = 400' 1:35" Factor of 10 datum level 10 ohm-meters

3-electrode array

NOTE: INTERLINE SPACING NOT TO SCALE

Department of
 Mines and Technical Surveys
 Assessment Branch
 No. 3892 #5



PLATE 3

CANADIAN JOHNS-MANVILLE Co. LIMITED

PROJECT 410

LAC LE JEUNE GRID

INDUCED POLARIZATION SURVEY

SCALE: 1" = 200'

SURVEY BY SEIGEL ASSOCIATES LIMITED

JUNE-1971



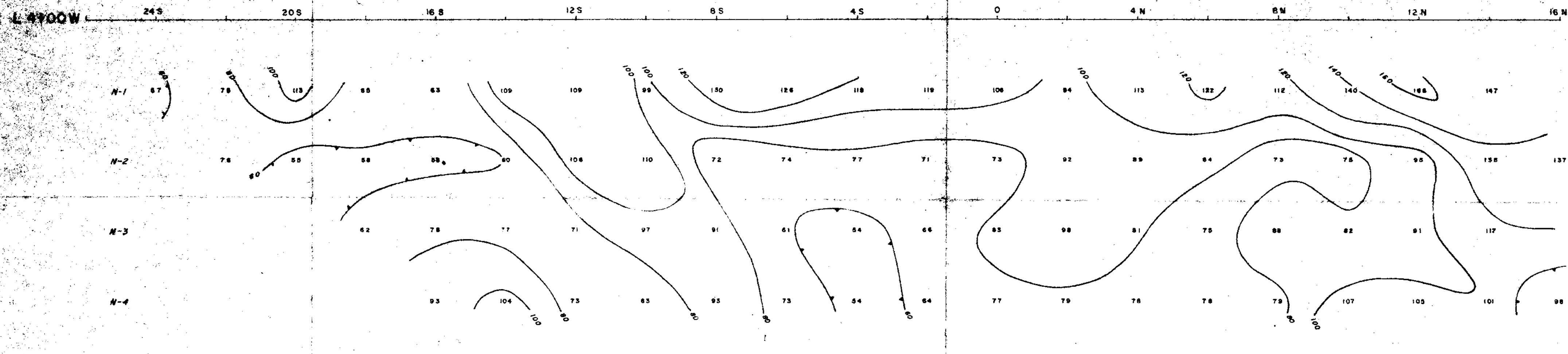

RESISTIVITY

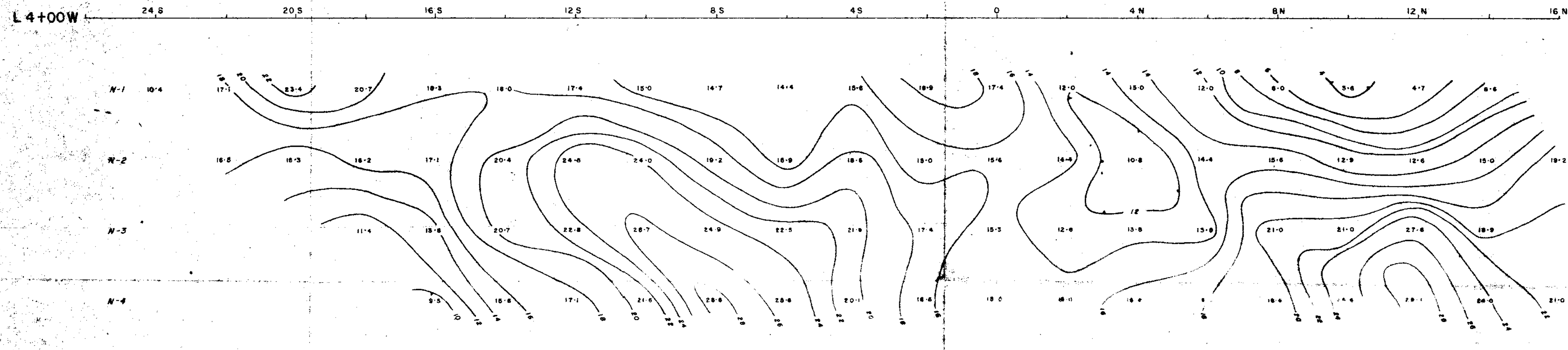

CHARGEABILITY

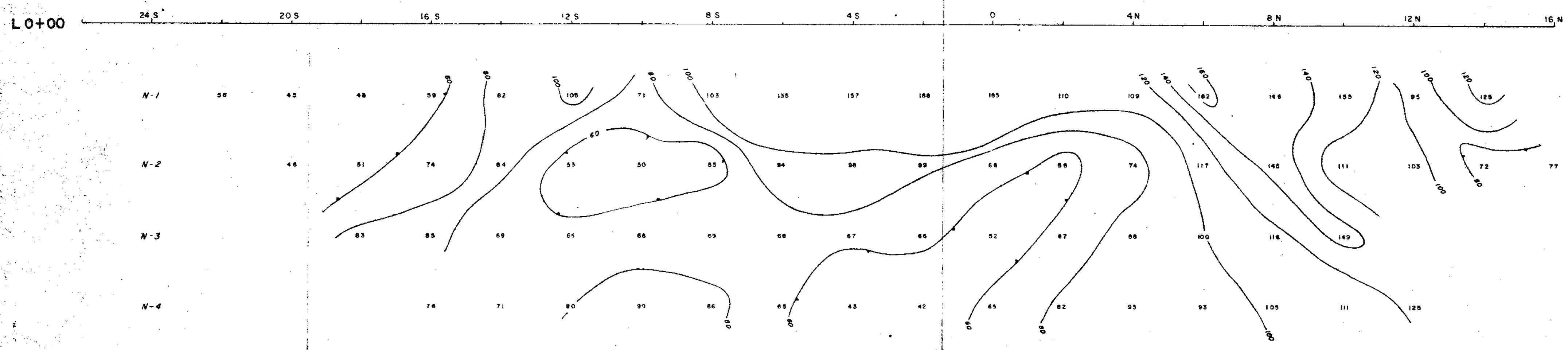

RESISTIVITY

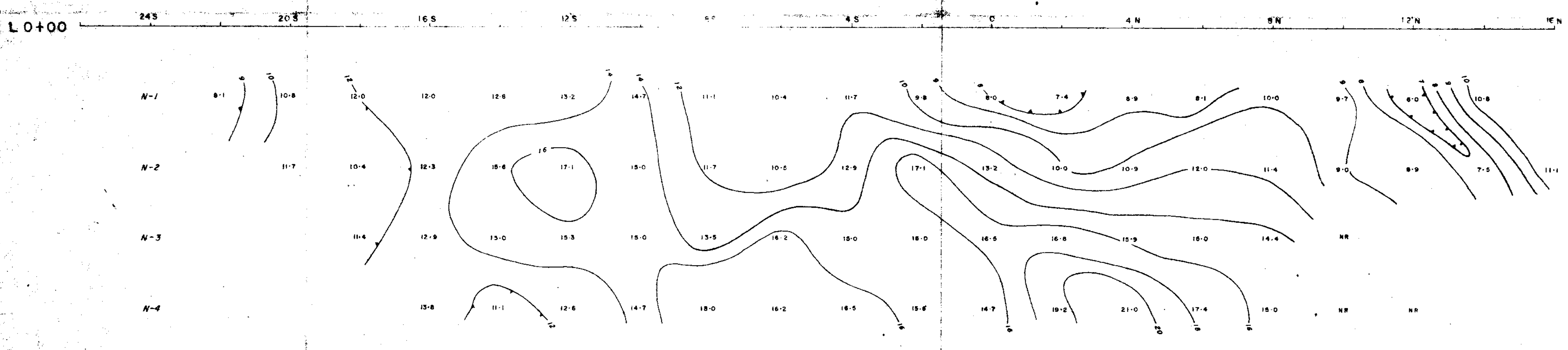

CHARGEABILITY

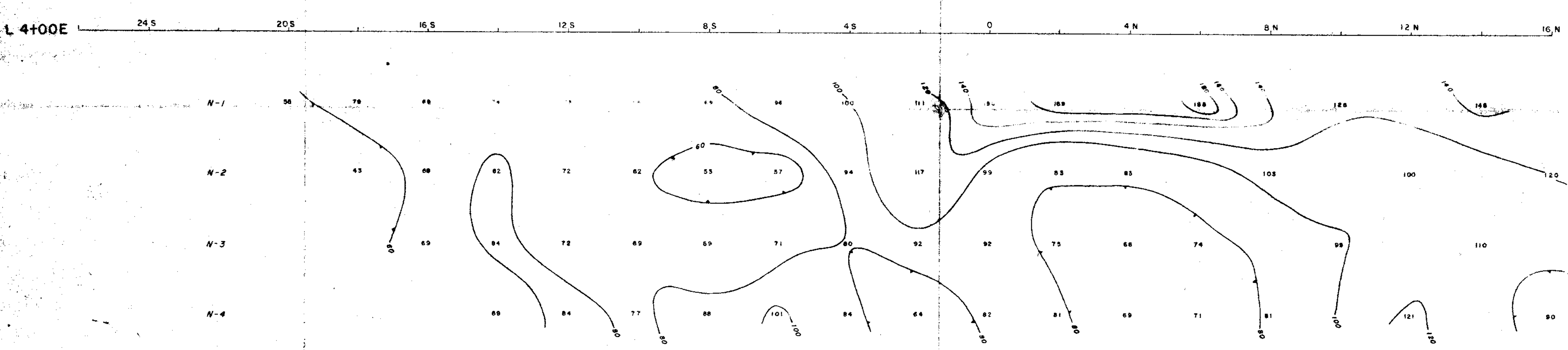

RESISTIVITY

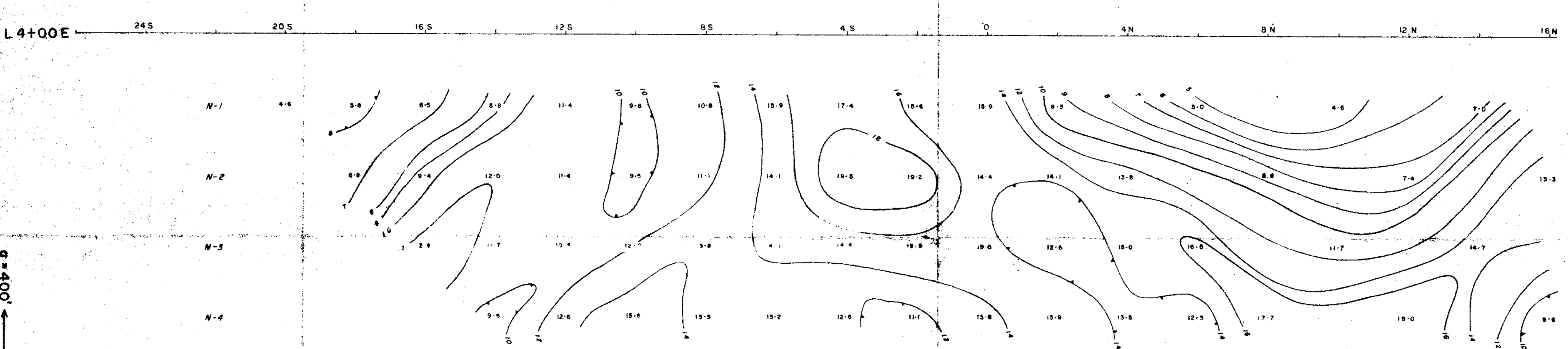

CHARGEABILITY

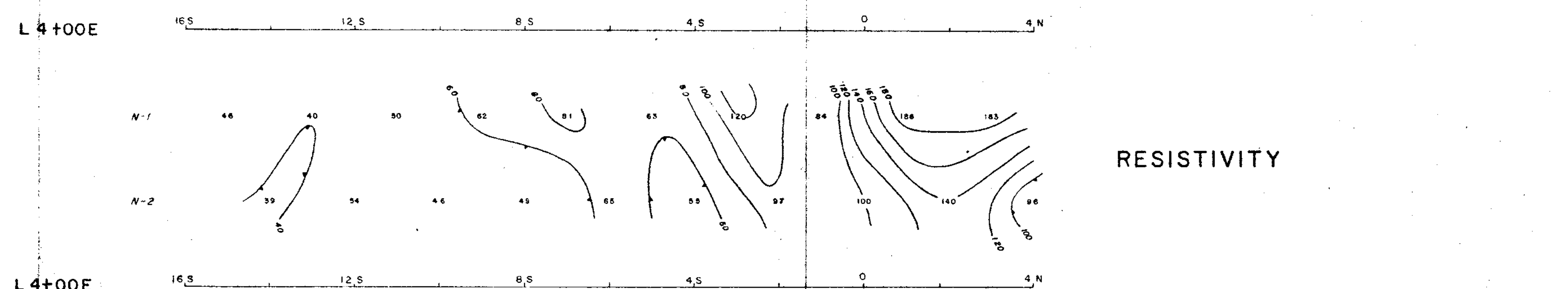
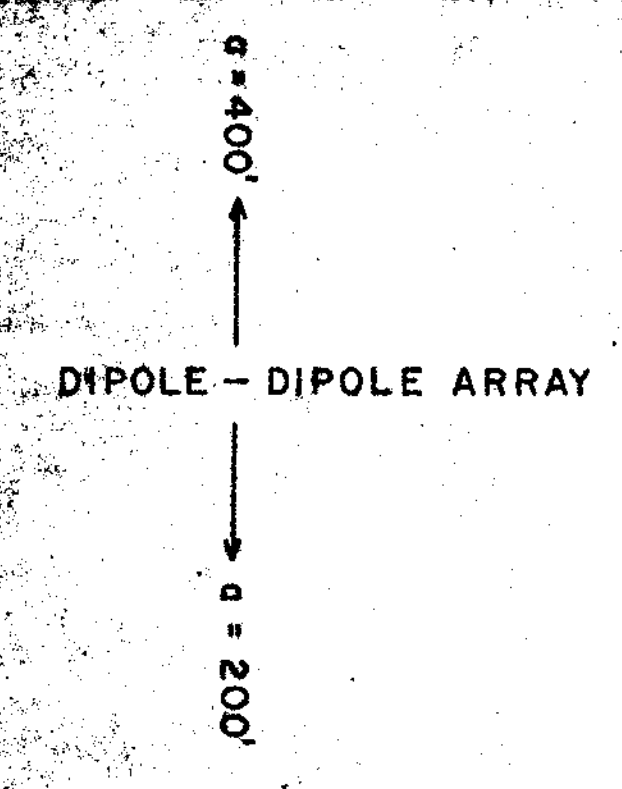
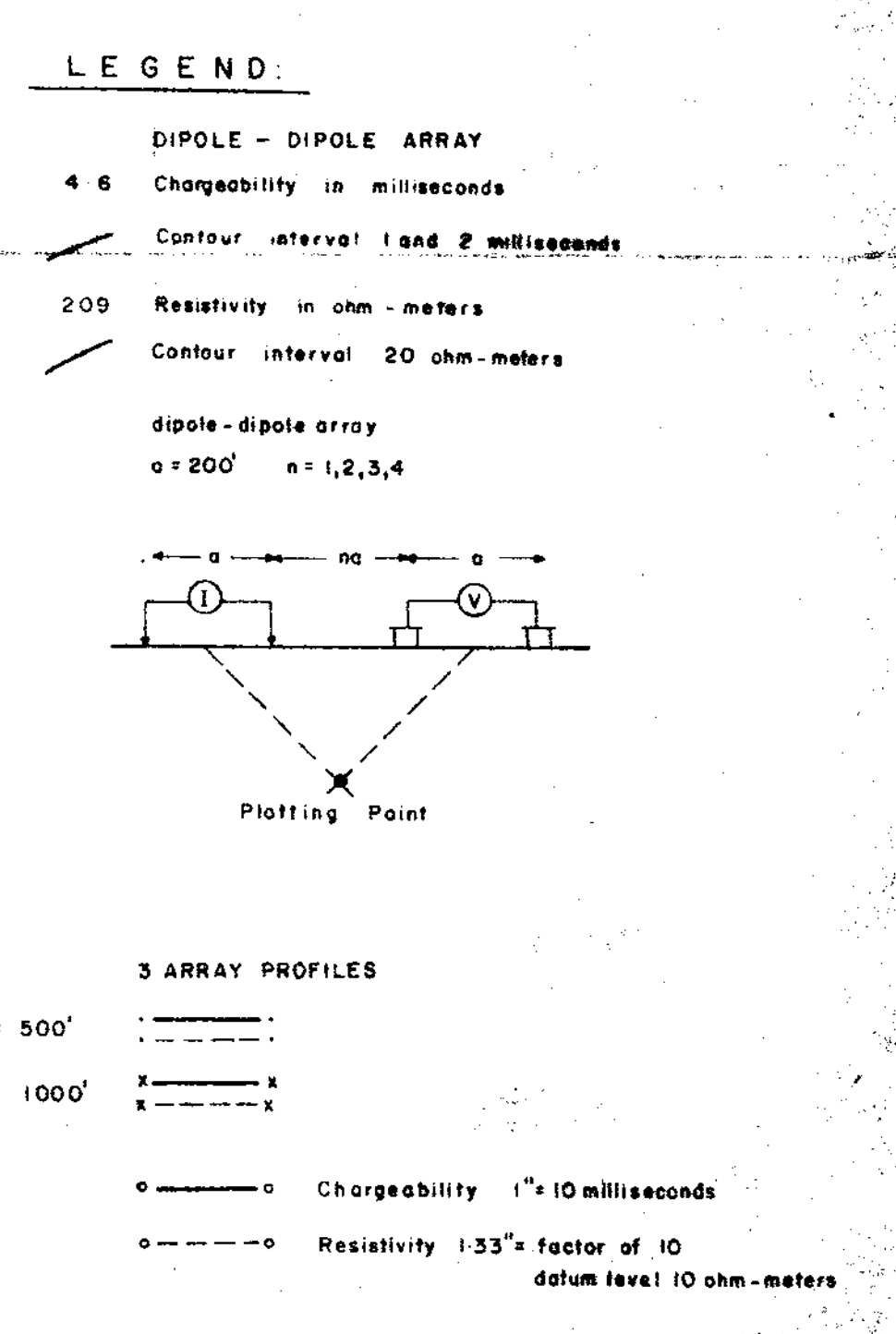
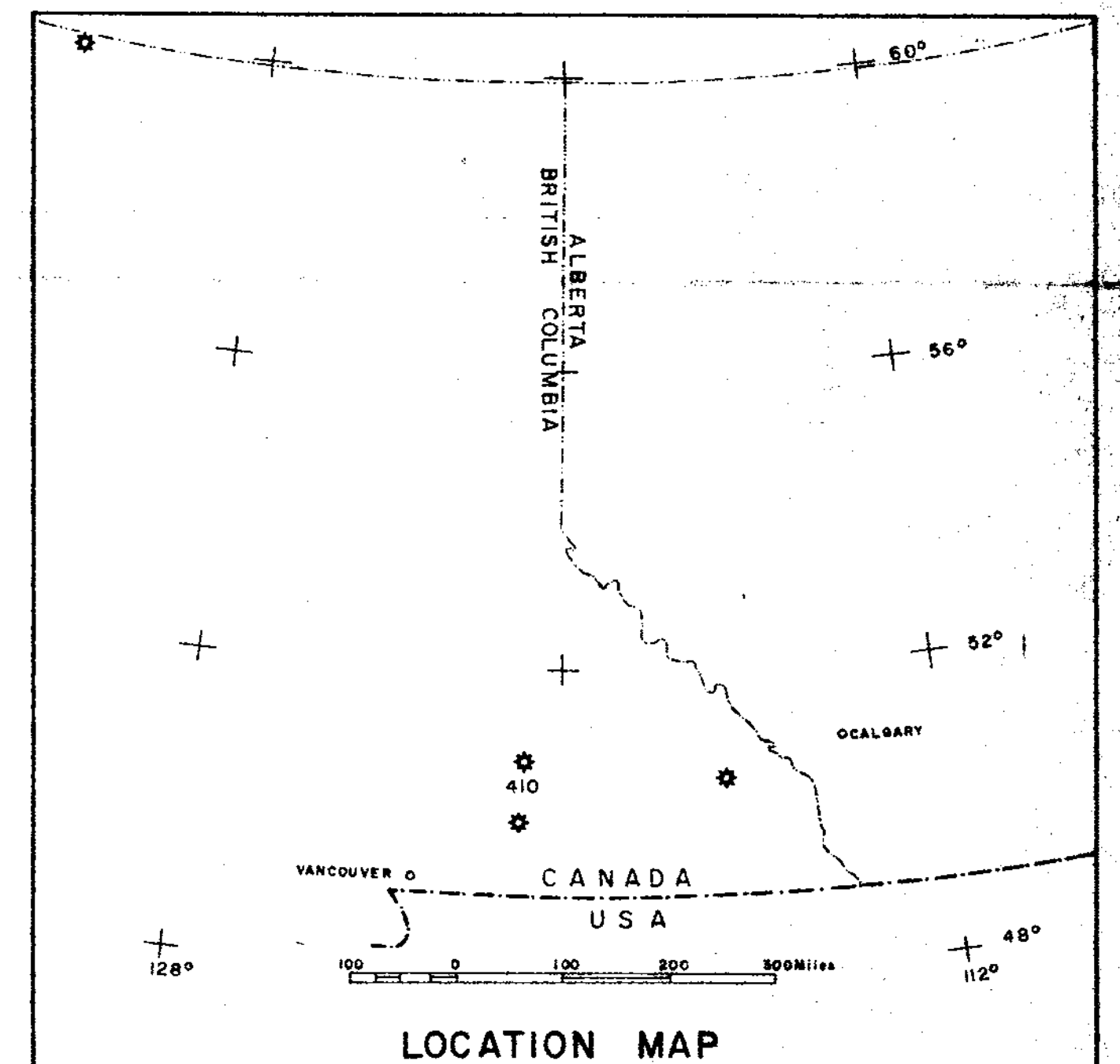

RESISTIVITY

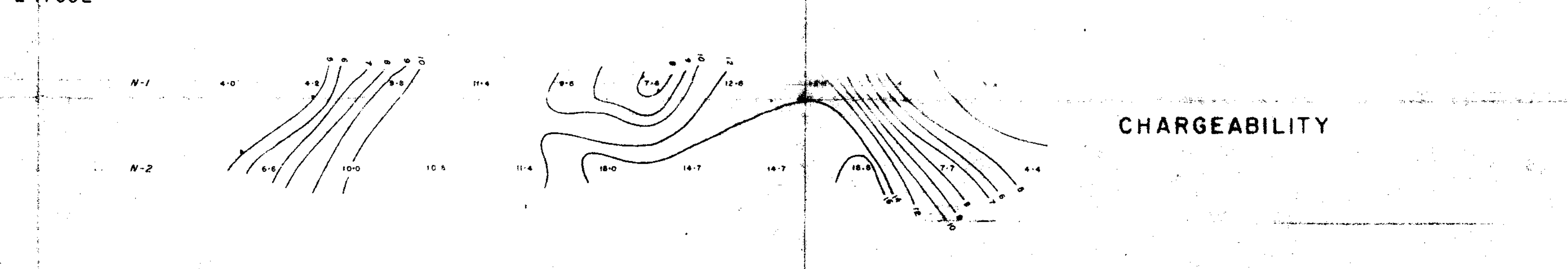

CHARGEABILITY

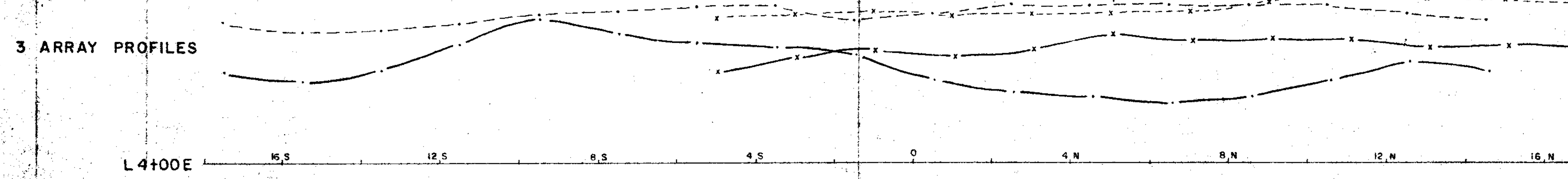

3 ARRAY PROFILES

Department of
Mineral and Petroleum Resources
ASSESSMENT REPORT
NO. 3892 MAP #3

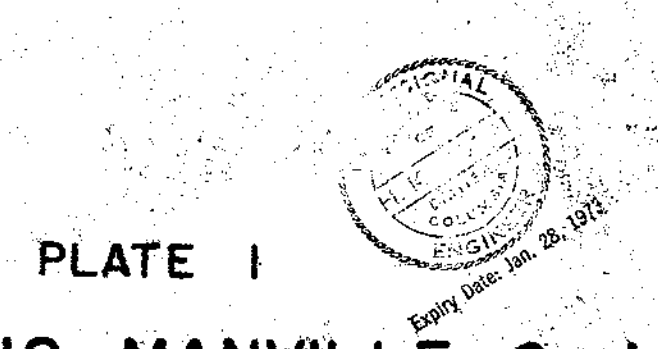
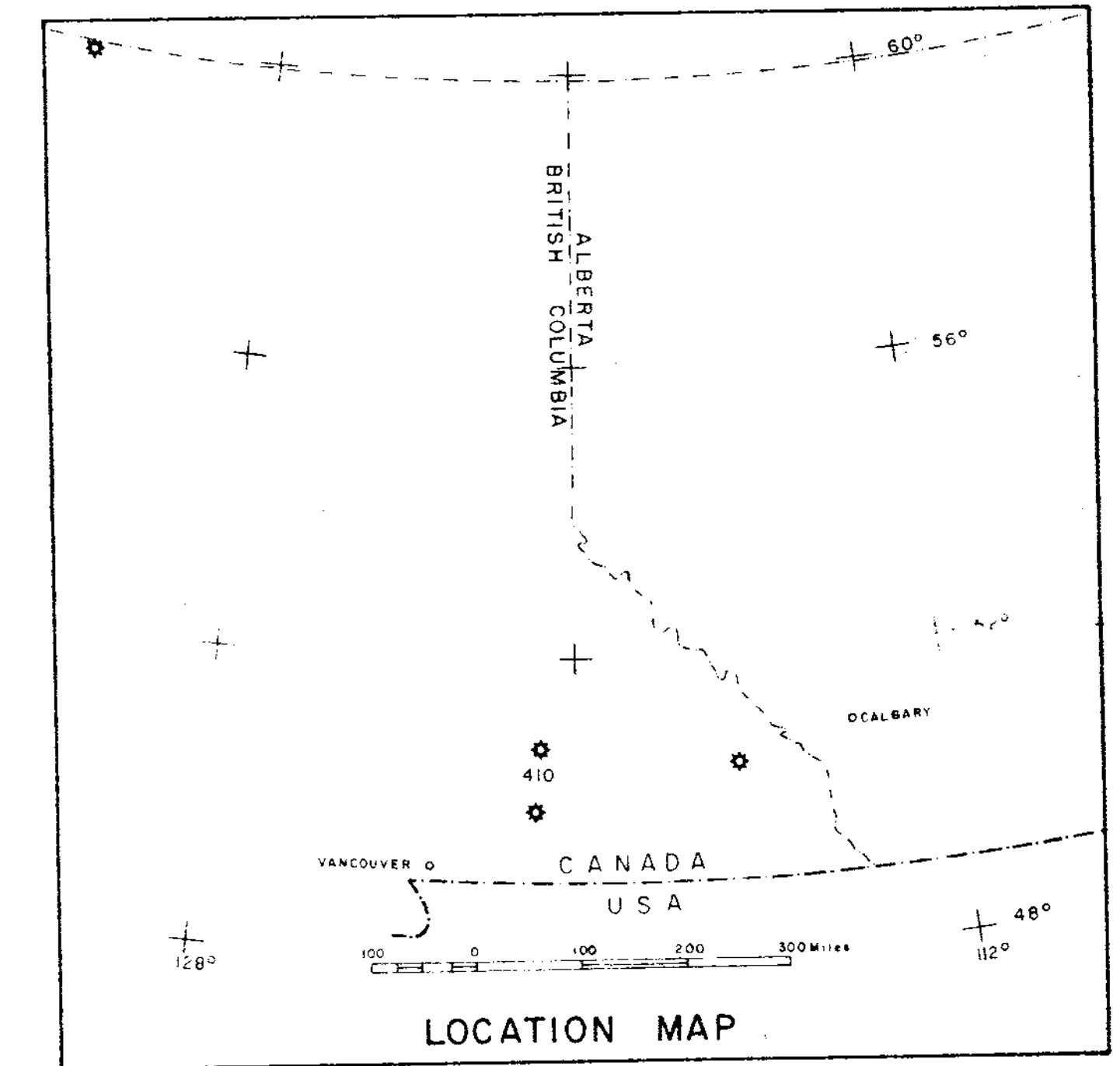
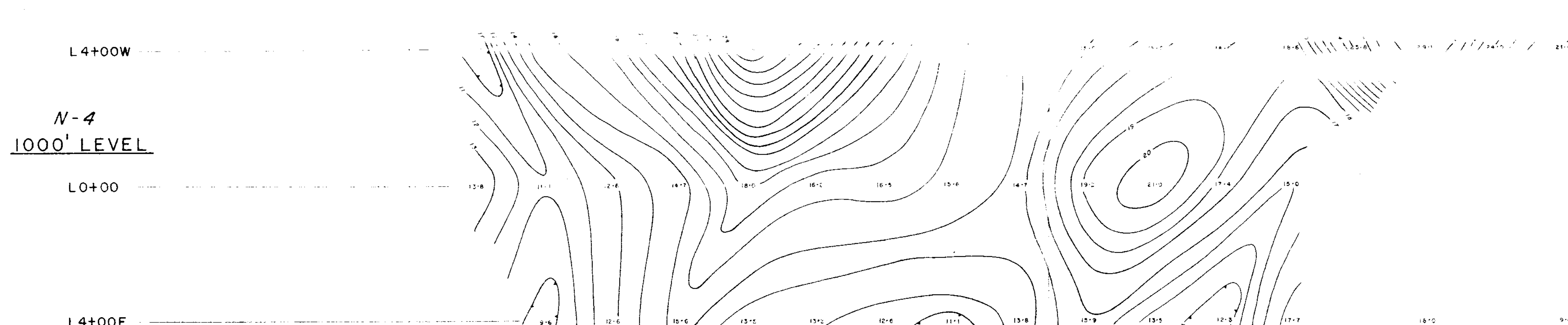
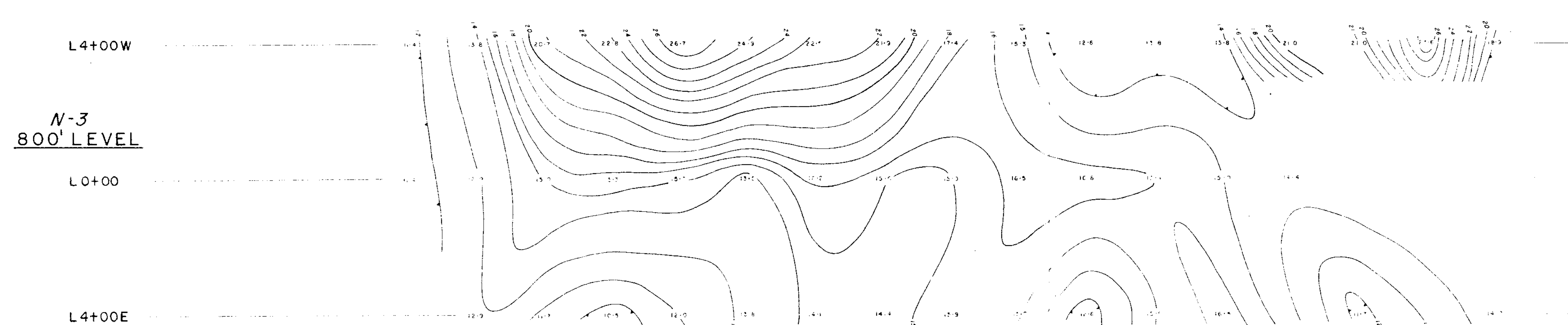
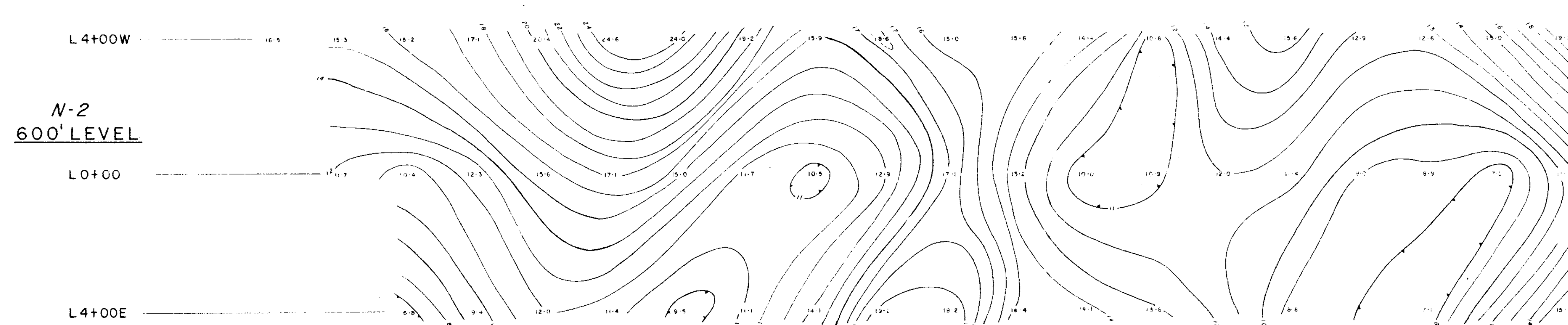
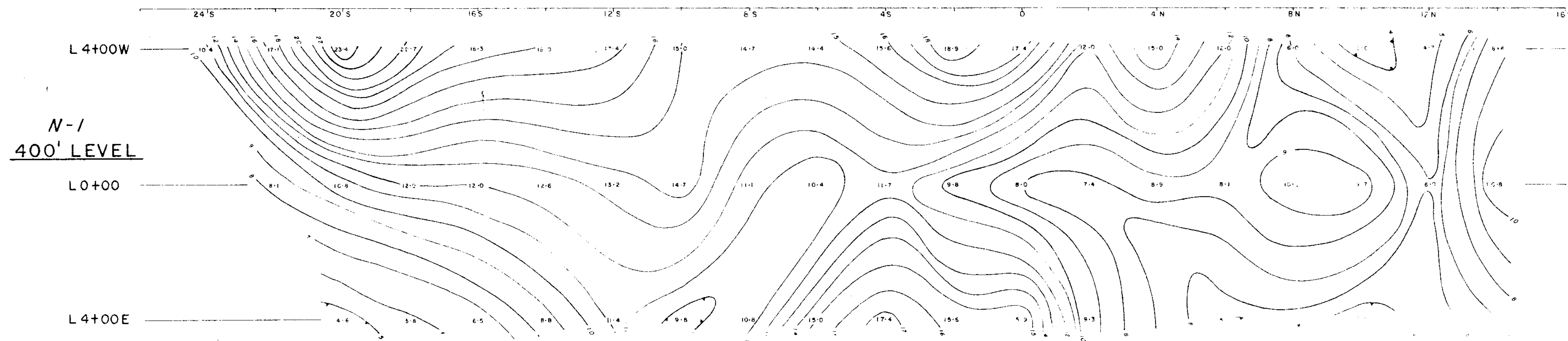

PLATE I
CANADIAN JOHNS-MANVILLE Co. LIMITED

PROJECT 410
LAND R ROAD GRID
INDUCED POLARIZATION SURVEY
SCALE: 1" = 200'

SURVEY BY SEIGEL ASSOCIATES LIMITED
MAY - JUNE 1971



LEGEND

- 7.5 Chargeability in milliseconds
- Contour interval 1 millisecond

Note: Plans show contours at different n-levels for lines 4E, 0 and 4W employing dipole-dipole array as 400'

Department of
Mines and Technical Resources
ASSESSMENT REPORT
NO. 3892 #4



PLATE 2
CANADIAN JOHNS-MANVILLE Co. LIMITED

PROJECT 410
L AND R ROAD GRID
INDUCED POLARIZATION SURVEY

SCALE: 1" = 200'
SURVEY BY SEIGEL ASSOCIATES LIMITED

MAY - JUNE 1971



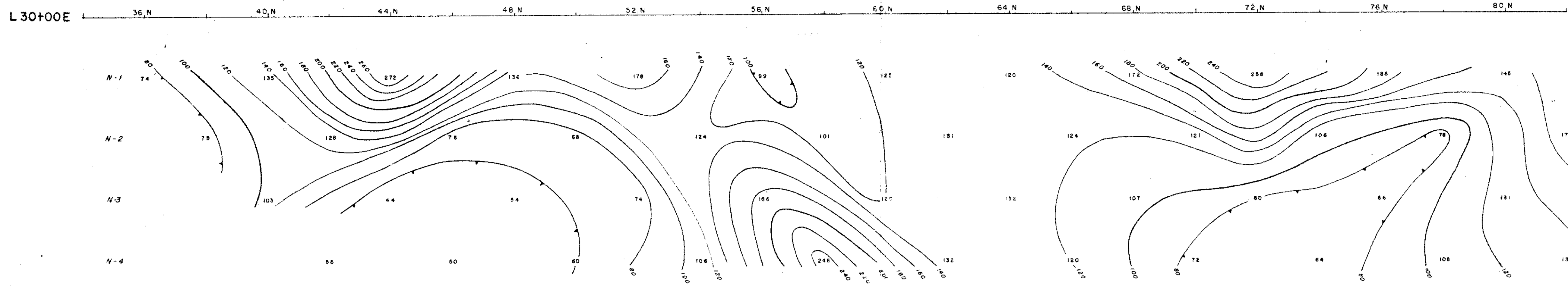

RESISTIVITY

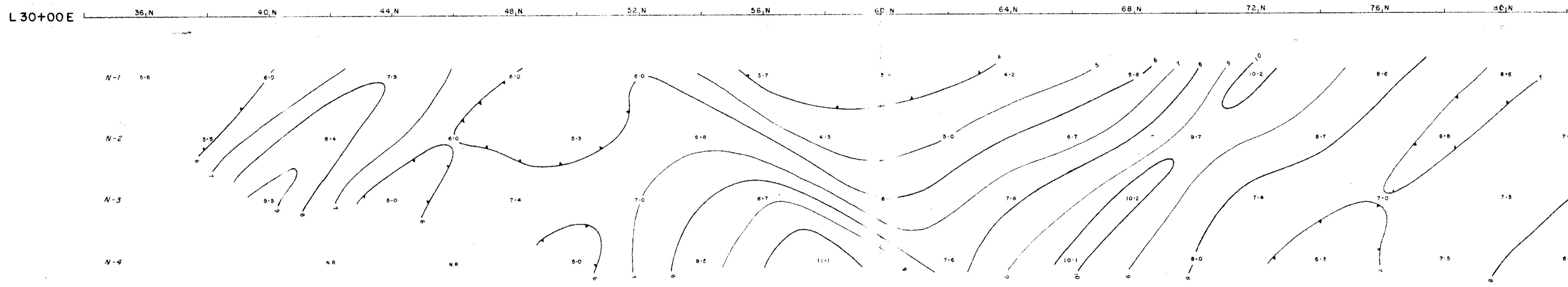

CHARGEABILITY

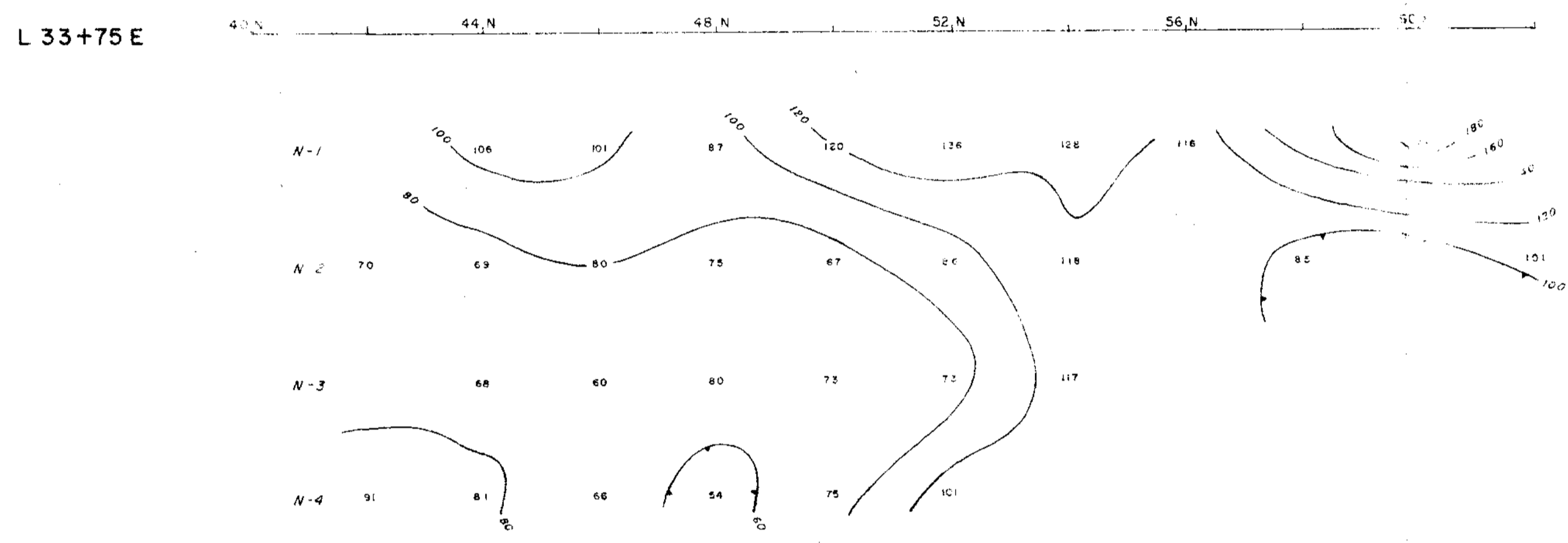

RESISTIVITY

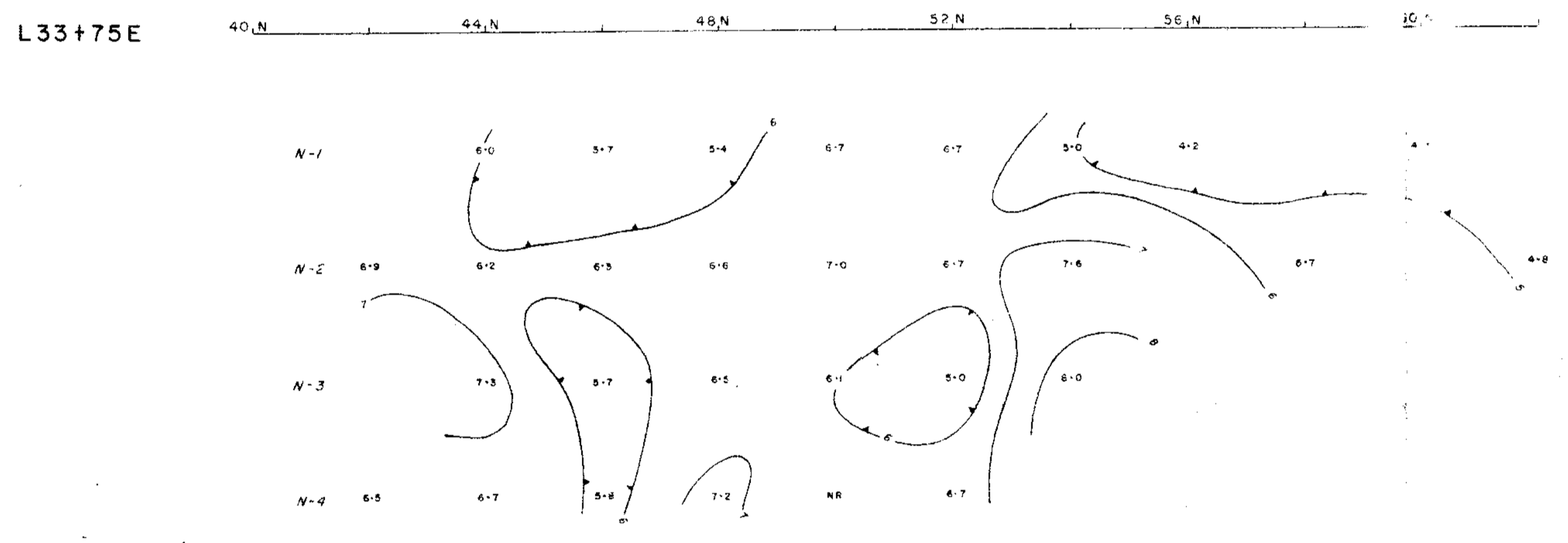

CHARGEABILITY

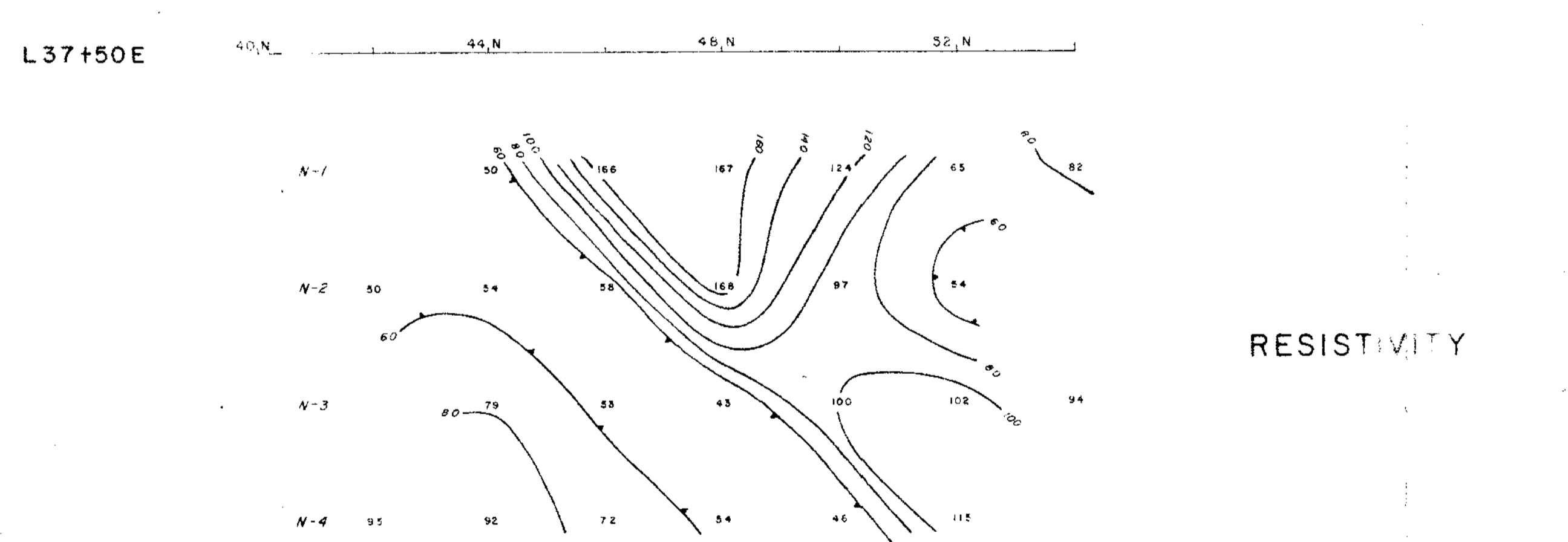

RESISTIVITY

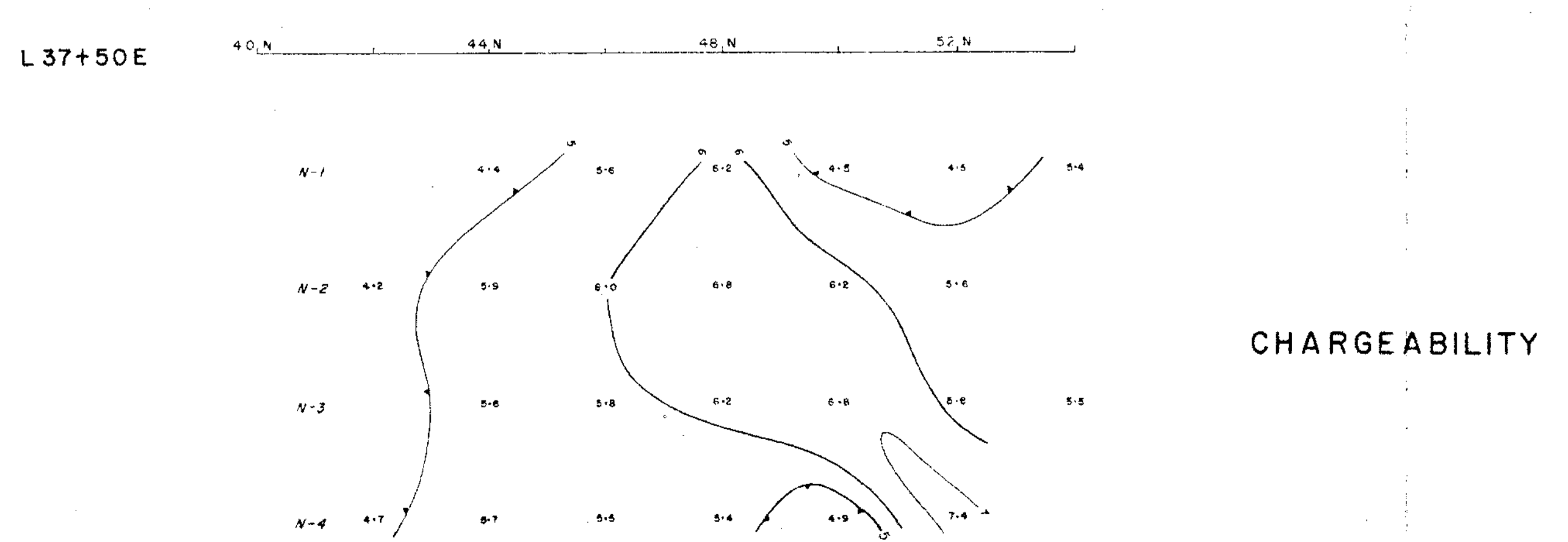

CHARGEABILITY

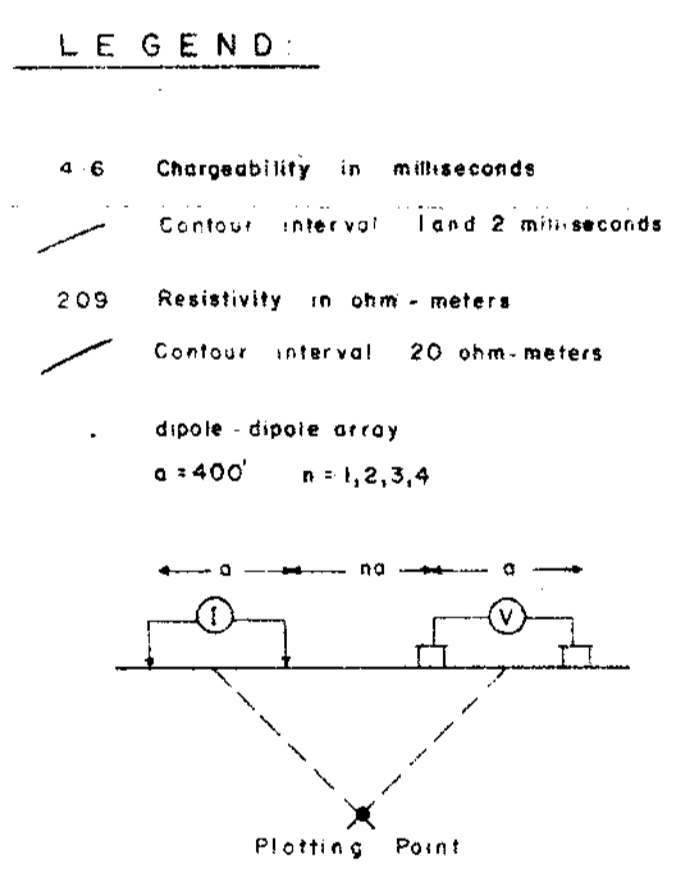
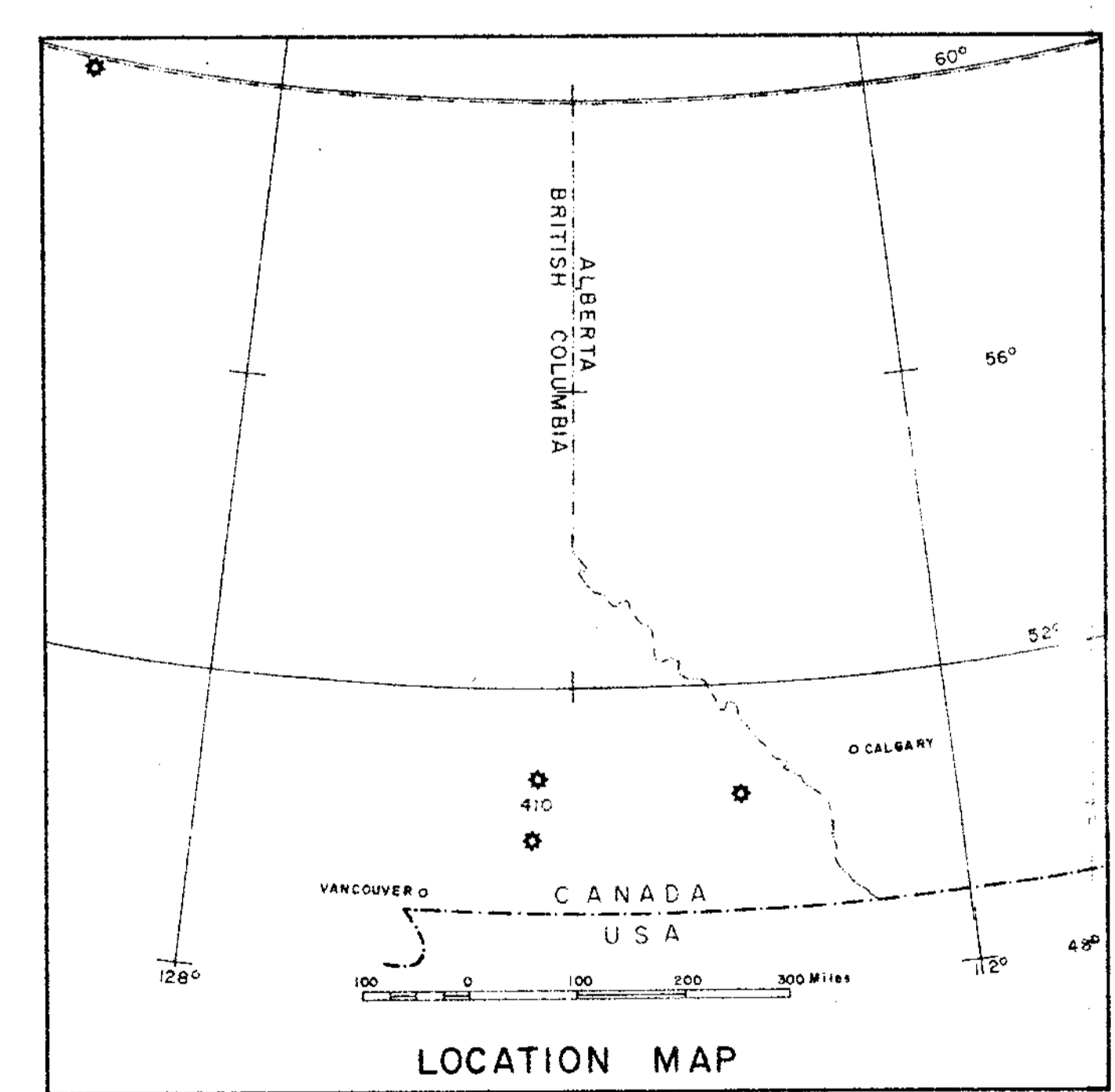

Department of
Mines and Technical Resources
ASSOCIATION REPORT
NO. 3892 MAP #7

PLATE 5
CANADIAN JOHNS-MANVILLE Co. LIMITED

PROJECT 410
GRID II. AND III.
INDUCED POLARIZATION SURVEY

SCALE: 1" = 200'
SURVEY BY SEIGEL ASSOCIATES LIMITED

MAY-AUG. 1971

