

4166

REPORT ON THE 92H/10E
INDUCED POLARIZATION
AND RESISTIVITY SURVEY
ON THE
KALCO VALLEY MINES LTD. (N.P.L.) OPTION
SUMMERS CREEK VALLEY, TULAMEEN AREA,
SIMILKAMEEN MINING DIVISION, B.C.
FOR
ISO EXPLORATIONS LTD.

BY

ASHTON W. MULLAN, B.Sc. P. Eng.

And

MARION A. GOUDIE, B.Sc.

Department of Mines and Petroleum Resources ASSESSMENT REPORT NO. 4166 MAP

NAME AND LOCATION OF PROPERTY:

SUMMERS CREEK VALLEY, TULAMEEN AREA,
SIMILKAMEEN MINING DIVISION, B.C. 49°38'N - 120°31'W

DATE STARTED: AUGUST 1, 1972

DATE FINISHED: SEPTEMBER 2, 1972

McPHAR GEOPHYSICS

NOTES ON THE THEORY, METHOD OF FIELD OPERATION, AND PRESENTATION OF DATA FOR THE INDUCED POLARIZATION METHOD

Induced Polarization as a geophysical measurement refers to the blocking action or polarization of metallic or electronic conductors in a medium of ionic solution conduction.

This electro-chemical phenomenon occurs wherever electrical current is passed through an area which contains metallic minerals such as base metal sulphides. Normally, when current is passed through the ground, as in resistivity measurements, all of the conduction takes place through ions present in the water content of the rock, or soil, i. e. by ionic conduction. This is because almost all minerals have a much higher specific resistivity than ground water. The group of minerals commonly described as "metallic", however, have specific resistivities much lower than ground waters. The induced polarization effect takes place at those interfaces where the mode of conduction changes from ionic in the solutions filling the interstices of the rock to electronic in the metallic minerals present

in the rock.

The blocking action or induced polarization mentioned above, which depends upon the chemical energies necessary to allow the ions to give up or receive electrons from the metallic surface, increases with the time that a d. c. current is allowed to flow through the rock; i. e. as ions pile up against the metallic interface the resistance to current flow increases. Eventually, there is enough polarization in the form of excess ions at the interfaces, to appreciably reduce the amount of current flow through the metallic particle. This polarization takes place at each of the infinite number of solution-metal interfaces in a mineralized rock.

When the d. c. voltage used to create this d. c. current flow is cut off, the Coulomb forces between the charged ions forming the polarization cause them to return to their normal position. This movement of charge creates a small current flow which can be measured on the surface of the ground as a decaying potential difference.

From an alternate viewpoint it can be seen that if the direction of the current through the system is reversed repeatedly before the polarization occurs, the effective resistivity of the system as a whole will change as the frequency of the switching is changed. This is a consequence of the fact that the amount of current flowing through each metallic interface depends upon the length of time that current has been passing through it in one direction.

The values of the per cent frequency effect or F. E. are a measurement of the polarization in the rock mass. However, since the measurement of the degree of polarization is related to the apparent resistivity of the rock mass it is found that the metal factor values or M. F. are the most useful values in determining the amount of polarization present in the rock mass. The MF values are obtained by normalizing the F. E. values for varying resistivities.

The induced polarization measurement is perhaps the most powerful geophysical method for the direct detection of metallic sulphide mineralization, even when this mineralization is of very low concentration. The lower limit of volume per cent sulphide necessary to produce a recognizable IP anomaly will vary with the geometry and geologic environment of the source, and the method of executing the survey. However, sulphide mineralization of less than one per cent by volume has been detected by the IP method under proper geological conditions.

The greatest application of the IP method has been in the search for disseminated metallic sulphides of less than 20% by volume. However, it has also been used successfully in the search for massive sulphides in situations where, due to source geometry, depth of source, or low resistivity of surface layer, the EM method can not be successfully applied. The ability to differentiate ionic conductors, such as water filled shear zones, makes the IP method a useful tool in checking EM

anomalies which are suspected of being due to these causes.

In normal field applications the IP method does not differentiate between the economically important metallic minerals such as chalcopyrite, chalcocite, molybdenite, galena, etc., and the other metallic minerals such as pyrite. The induced polarization effect is due to the total of all electronic conducting minerals in the rock mass. Other electronic conducting materials which can produce an IP response are magnetite, pyrolusite, graphite, and some forms of hematite.

In the field procedure, measurements on the surface are made in a way that allows the effects of lateral changes in the properties of the ground to be separated from the effects of vertical changes in the properties. Current is applied to the ground at two points in distance (X) apart. The potentials are measured at two other points (X) feet apart, in line with the current electrodes is an integer number (n) times the basic distance (X).

The measurements are made along a surveyed line, with a constant distance (nX) between the nearest current and potential electrodes. In most surveys, several traverses are made with various values of (n); i. e. (n) = 1, 2, 3, 4, etc. The kind of survey required (detailed or reconnaissance) decides the number of values of (n) used.

In plotting the results, the values of the apparent resistivity, apparent per cent frequency effect, and the apparent metal factor

measured for each set of electrode positions are plotted at the intersection of grid lines, one from the center point of the current electrodes and the other from the center point of the potential electrodes. (See Figure A.) The resistivity values are plotted above the line as a mirror image of the metal factor values below. On a second line, below the metal factor values, are plotted the values of the per cent frequency effect. In some cases the values of per cent frequency effect are plotted as superscripts of the metal factor value. In this second case the frequency effect values are not contoured. The lateral displacement of a given value is determined by the location along the survey line of the center point between the current and potential electrodes. The distance of the value from the line is determined by the distance (nX) between the current and potential electrodes when the measurement was made.

The separation between sender and receiver electrodes is only one factor which determines the depth to which the ground is being sampled in any particular measurement. The plots then, when contoured, are not section maps of the electrical properties of the ground under the survey line. The interpretation of the results from any given survey must be carried out using the combined experience gained from field results, model study results and theoretical investigations. The position of the electrodes when anomalous values are measured is important in the interpretation.

In the field procedure, the interval over which the potential differences are measured is the same as the interval over which the electrodes are moved after a series of potential readings has been made. One of the advantages of the induced polarization method is that the same equipment can be used for both detailed and reconnaissance surveys merely by changing the distance (X) over which the electrodes are moved each time. In the past, intervals have been used ranging from 25 feet to 2000 feet for (X). In each case, the decision as to the distance (X) and the values of (n) to be used is largely determined by the expected size of the mineral deposit being sought, the size of the expected anomaly and the speed with which it is desired to progress.

The diagram in Figure A demonstrates the method used in plotting the results. Each value of the apparent resistivity, apparent metal factor, and apparent per cent frequency effect is plotted and identified by the position of the four electrodes when the measurement was made. It can be seen that the values measured for the larger values of (n) are plotted farther from the line indicating that the thickness of the layer of the earth that is being tested is greater than for the smaller values of (n); i. e. the depth of the measurement is increased. When the F. E. values are plotted as superscripts to the MF values the third section of data values is not presented and the F. E. values are not contoured.

The actual data plots included with the report are prepared utilizing an IBM 360/75 Computer and a Calcomp 770/763 Incremental Plotting System. The data values are calculated, plotted, and contoured according to a programme developed by McPhar Geophysics. Certain symbols have been incorporated into the programme to explain various situations in recording the data in the field.

The IP measurement is basically obtained by measuring the difference in potential or voltage (ΔV) obtained at two operating frequencies. The voltage is the product of the current through the ground and the apparent resistivity of the ground. Therefore in field situations where the current is very low due to poor electrode contact, or the apparent resistivity is very low, or a combination of the two effects; the value of (ΔV) the change in potential will be too small to be measurable. The symbol "TL" on the data plots indicates this situation.

In some situations spurious noise, either man made or natural, will render it impossible to obtain a reading. The symbol "N" on the data plots indicates a station at which it is too noisy to record a reading. If a reading can be obtained, but for reasons of noise there is some doubt as to its accuracy, the reading is bracketed in the data plot ().

In certain situations negative values of Apparent Frequency Effect are recorded. This may be due to the geologic environment or spurious electrical effects. The actual negative frequency effect value recorded is indicated on the data plot, however the symbol "NEG" is

indicated for the corresponding value of Apparent Metal Factor. In contouring negative values the contour lines are indicated to the nearest positive value in the immediate vicinity of the negative value.

The symbol "NR" indicates that for some reason the operator did not attempt to record a reading although normal survey procedures would suggest that one was required. This may be due to inaccessible topography or other similar reasons. Any symbol other than those discussed above is unique to a particular situation and is described within the body of the report.

METHOD USED IN PLOTTING DIPOLE-DIPOLE INDUCED POLARIZATION AND RESISTIVITY RESULTS

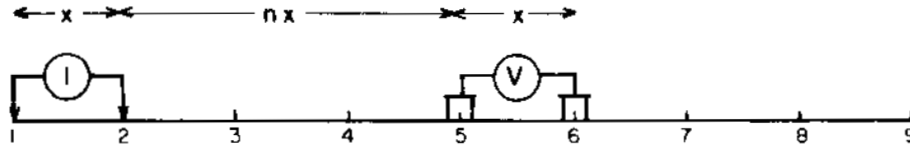

Stations on line

x = Electrode spread length
 n = Electrode separation

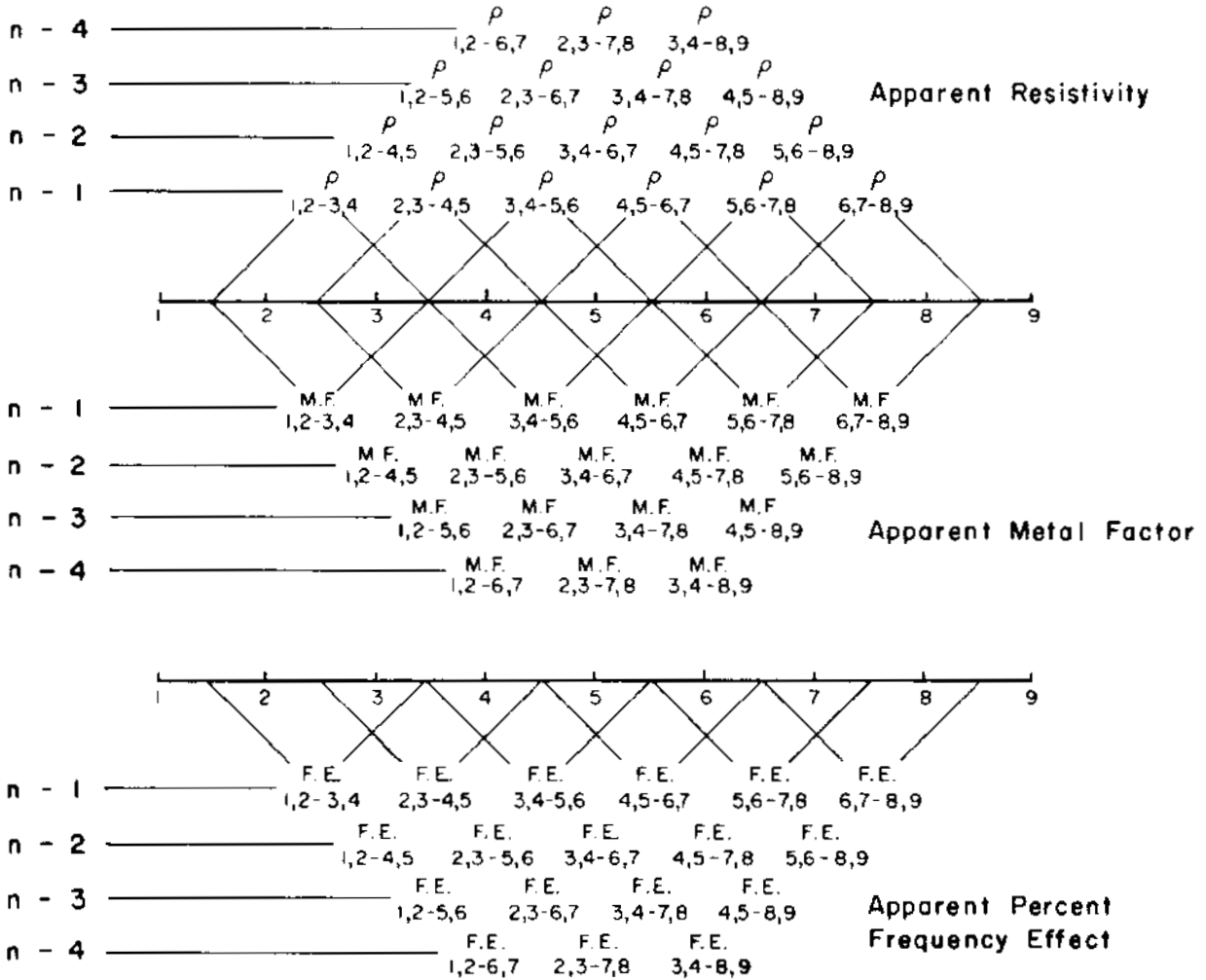

Fig. A

TABLE OF CONTENTS

<u>Part A:</u>	Notes on theory and field procedure	9 pages	
<u>Part B:</u>	Report	13 pages	<u>Page</u>
1.	Introduction		1
2.	Presentation of Results		3
3.	Discussion Of Results		5
4.	Conclusions		9
5.	Assessment Details		10
6.	Statement of Cost		11
7.	Certificate - A.W. Mullan		12
8.	Certificate - M.A. Goudie		13
9.	Appendix I		
10.	Appendix II		
<u>Part C:</u>	Illustrations	31 pieces	
	# Plan Map (in pocket)	Dwg. I.P.P. 4874	
	IP Data Plots	Dwgs. IP 6010-1 to -30	

McPHAR GEOPHYSICS LIMITED

REPORT ON THE

INDUCED POLARIZATION

AND RESISTIVITY SURVEY

ON THE

KALCO VALLEY MINES LTD. (N.P.L.) OPTION

SUMMERS CREEK VALLEY, TULAMEEN AREA,

SIMILKAMEEN MINING DIVISION, B.C.

FOR

ISO EXPLORATIONS LTD.

1. INTRODUCTION

At the request of Mr. W. O. Brady, General Manager of the company, we have completed an Induced Polarization and Resistivity Survey on the Kalco Valley Mines Ltd., (N.P.L.) Option in the Summers Creek Valley, Tulameen area, Similkameen Mining Division, British Columbia, for Iso Explorations Ltd. Access to the property, which lies 14 miles north of Princeton, B. C., is by paved Highway No. 5 north from Princeton for 6 miles, then north on the all-weather gravel Summers Creek road for 8 miles. The survey grid is situated at $49^{\circ}38'N$ latitude and $120^{\circ}31'W$ longitude.

The property lies in the Princeton-Aspen Grove copper belt. The mineralization occurs in Triassic Nicola volcanic rocks and related alkali and calc-alkali intrusions. The property is adjacent to a major

north-south trending fault that occupies the Summers Creek valley.

Underlying rocks consist of volcanic sediments, pyroclastics and intrusive breccias which have been intruded by quartz diorite and granodiorite stocks. A pyritic zone, similar to one to the southwest, extends into the surrounding volcanic rocks forming rusty outcrops on the hillside.

Previous work on the property consisted of 4 rotary holes and 6 percussion holes, followed by geochemical, ground magnetometer and geological surveys and 17 further percussion holes. Heavy overburden hindered the drilling and six holes failed to reach bedrock.

Pyrite, chalcopyrite, molybdenite and magnetite have been identified from cuttings and country rock. Core from the 4 rotary holes also carried minor amounts of silver. The mineralization appears to show a zonal pattern of pyrite, pyrite-chalcopyrite, pyrite-magnetite-molybdenite around a quartz stock in the centre of the property.

The IP survey was carried out to outline disseminated metallic mineralization which might be present. The work was completed in August and the first day of September, 1972, using a McPhar P660 high power variable frequency IP unit operating at 0.3 and 5.0 cps over the following claims:

Pip - 1 to 16 inclusive, Fraction 2
OK - 19 to 27 inclusive, 29, 30, 31, 32, 40, 42, 44, 46

This property is held under option from Kalco Valley Mines Ltd. (N.P.L.) by Iso Explorations Ltd.

2. PRESENTATION OF RESULTS

The Induced Polarization and Resistivity results are shown on the following data plots in the manner described in the notes preceding this report.

<u>Line</u>	<u>Electrode Intervals</u>	<u>Dwg. No.</u>
1600N	300 feet	IP 6010-1
1200N	300 feet	IP 6010-2
800N	300 feet	IP 6010-3
400N	300 feet	IP 6010-4
0	300 feet	IP 6010-5
400S	300 feet	IP 6010-6
800S	300 feet	IP 6010-7
1200S	300 feet	IP 6010-8
1600S	300 feet	IP 6010-9
2000S	300 feet	IP 6010-10
2400S	300 feet	IP 6010-11
2800S	300 feet	IP 6010-12
3200S	300 feet	IP 6010-13
3600S	300 feet	IP 6010-14
4000S	300 feet	IP 6010-15
4400S	300 feet	IP 6010-16
4800S	300 feet	IP 6010-17
5200S	300 feet	IP 6010-18
5600S	300 feet	IP 6010-19
6000S	300 feet	IP 6010-20

<u>Line</u>	<u>Electrode Intervals</u>	<u>Dwg. No.</u>
6400S	300 feet	IP 6010-21
6800S	300 feet	IP 6010-22
7200S	300 feet	IP 6010-23
7600S	300 feet	IP 6010-24
8000S	300 feet	IP 6010-25
8400S	300 feet	IP 6010-26
8800S	300 feet	IP 6010-27
9200S	300 feet	IP 6010-28
9600S	300 feet	IP 6010-29
10000S	300 feet	IP 6010-30

Also enclosed with this report is Dwg. I.P.P. 4874, a plan map of the Kalco Valley Mines Option Grid at a scale of 1" = 400'. The definite, probable and possible Induced Polarization anomalies are indicated by bars, in the manner shown on the legend, on this plan map as well as on the data plots. These bars represent the surface projection of the anomalous zones as interpreted from the location of the transmitter and receiver electrodes when the anomalous values were measured.

Since the Induced Polarization measurement is essentially an averaging process, as are all potential methods, it is frequently difficult to exactly pinpoint the source of an anomaly. Certainly, no anomaly can be located with more accuracy than the electrode interval length; i. e. when using 200' electrode intervals the position of a narrow sulphide body can only be determined to lie between two stations 200' apart. In order to definitely locate, and fully evaluate, a narrow, shallow source it is necessary to use

shorter electrode intervals. In order to locate sources at some depth, larger electrode intervals must be used, with a corresponding increase in the uncertainties of location. Therefore, while the centre of the indicated anomaly probably corresponds fairly well with source, the length of the indicated anomaly along the line should not be taken to represent the exact edges of the anomalous material.

The drill hole information shown on Dwg. I.P.P. 4874 has been taken from maps made available by the staff of Iso Explorations Ltd., and the locations are only approximate.

3. DISCUSSION OF RESULTS

Information provided by the client suggested the presence of zoned sulphide mineralization, grading from pyrite eastward through weak pyrite-chalcopyrite to pyrite-magnetite-molybdenite. The purpose of the IP survey was to detect and outline disseminated mineralization. The IP results do indeed detect metallic mineralization, but it is not possible to use these results to differentiate between different types of mineralization, e.g. pyrite and chalcopyrite. This is well illustrated in Appendix I, which shows the IP results on one line over the Bell orebody.

The results of the survey suggest that the mineralization which has been outlined varies in occurrence. Seven anomalous zones have been outlined; in addition, several anomalies have not been correlated at this time.

Zone A

Zone A is a broad zone which extends over much of the grid north of Line 32005. The anomalies vary in magnitude and in depth. The source

is probably disseminated mineralization containing erratic concentrations of mineralization. It is not really possible to correlate these zones of concentration with confidence, e. g. on Line 800S, the source of the definite anomaly from 36W to 39W is deep relative to the electrode interval, while on Line 1200S, the source of the definite anomaly from 36W to 39W is relatively shallow. On the same two lines, the northern anomaly from 28W to 33W is relatively deep, while the southern anomaly from 24W to 30W appears to represent a flat-lying, shallow source.

D. D. H. 71-3 on Line 0 should have tested the moderate anomaly from 42W to 45W. P. H. 70-8 penetrated deep enough to check the weakly anomalous source which should extend from Line 800N to Line 400N, but the results are not encouraging, showing only a very minor amount of copper. Similarly, R. H. 5, which should have tested a moderately anomalous portion of the zone, recovered only 0.07% Cu and 0.012% MOS_2 . D. D. H. 71-2 appears to have overshot the main anomalous source.

Zone A should be tested in several additional locations, some of which are suggested below. All depths mentioned are vertical depths below the stations.

- | | | |
|------------|---|----------------------------|
| Line 400S | - | (1) 150' to 200' below 43W |
| | - | (2) 150' below 39W |
| | - | (3) 150' to 200' below 36W |
| Line 1200S | - | (1) 150' below 40W |
| | - | (2) 200' below 37W |
| | - | (3) 150' below 27W |

Line 2800S - (1) 150' below 28W
- (2) 200' below 21W

Zone B

This zone appears on Line 3600S, Line 4000S and Line 4400S. The source appears to be a relatively narrow zone of concentrated mineralization with the top at a depth of less than half the electrode interval. The zone could be tested on Line 3600S with a hole to reach a vertical depth of 150' below 26W.

Zone C

Zone C is restricted to Line 3600S and Line 4000S. The source could be checked on Line 3600S where the top of the source is relatively shallow with a hole to reach 150' below 19W.

Zone D

This zone extends from Line 5200S to Line 6000S. The definite anomaly of the zone is flanked by a probable anomaly to the west on all three lines and to the east by a probable anomaly on Line 5200S and possible anomalies on Line 5600S and Line 6000S. The source could be tested on Line 5600S by (1) a hole to reach 150' below 28W and (2) a hole to reach 150' below 33W.

Zone E

This relatively narrow zone which is open to the south appears on Line 6800S, Line 7200S and Line 7600S. The source is shallow relative to the

electrode interval and would be better located by detailing with shorter electrode intervals. If this is not desirable, the source should be checked by an inclined hole on Line 7200S, collared at 28W and drilled 500' at an angle of 45° to the east.

Zone F

The Zone F anomalies on Line 7600S, Line 8000S and Line 8400S appear to represent disseminated mineralization which becomes weaker to the east. The top of the source is relatively shallow and could be checked by a hole drilled to reach 150' below 21W on Line 8400S.

Zone G

This zone consists primarily of possible anomalies representing weakly disseminated mineralization. The zone could be of economic interest if the mineralization which is the source of the anomalies were rich enough in molybdenum. This is shown in Appendix II, a paper on the use of IP at Brenda Mines, British Columbia, where the mineralization is very weakly disseminated. Some recommended drill locations are :

- Line 3600S - To reach 150' beneath 11W
- Line 5200S - To reach 200' beneath 9W
- Line 6000S - To reach 250' beneath 5W
- Line 9200S - To reach 250' beneath 16W

On Line 10000S, a definite anomaly from 18W to 27W, incomplete, may indicate the presence of a source to the northwest which has not been surveyed, or it may be the beginning of mineralization to the south. It could

be tested by a hole drilled to reach 150' beneath 22+50W. The anomaly should be detailed with shorter electrode intervals before drilling, however, since the source is shallow and its location can be better defined by shorter electrode intervals.

4. CONCLUSIONS

The IP results indicate that mineralization occurs in more than one form in the grid area. Seven anomalous IP zones have been outlined and recommendations have been made for testing the anomalies. It should be stressed here that before testing shallow anomalies, the anomalies should be detailed with shorter electrode intervals to better locate the source for drilling locations.

The drilling results should be used in conjunction with the IP results as a guide to further exploration.

McPHAR GEOPHYSICS LIMITED

Ashton W. Mullis
Geologist

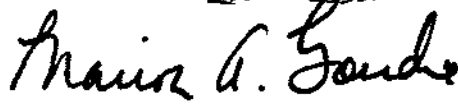

Marion A. Goudie,
Geologist

Dated: November 6, 1972

ASSESSMENT DETAILS

PROPERTY: Kalco Valley Mines Ltd.
(N. P. L.) Option

MINING DIVISION: Similkameen

SPONSOR: Iso Explorations Ltd.

PROVINCE: British Columbia

LOCATION: Summers Creek Valley

TYPE OF SURVEY: Induced Polarization

OPERATING MAN DAYS: 106

DATE STARTED: August 1, 1972

EQUIVALENT 8 HR. MAN DAYS: 179

DATE FINISHED: September 2, 1972

CONSULTING MAN DAYS: 4

NUMBER OF STATIONS: 510

DRAUGHTING MAN DAYS: 5

NUMBER OF READINGS: 3249

TOTAL MAN DAYS: 188

MILES OF LINE SURVEYED: 27.27

CONSULTANTS:

Ashton W. Mullan, 1440 Sandhurst Place, West Vancouver, B. C.
Marion A. Goudie, 739 Military Trail, West Hill, Ontario.

FIELD TECHNICIANS:

G. Trefenanko, Box 923, Lac La Biche, Alberta.
D. Irish, 3592 Quesnel Drive, Vancouver 8, B. C.
Plus Extra Labour:
J. Adlington, 852 Georgeann Road, Kamloops, B. C.
G. Silver, 852 Georgeann Road, Kamloops, B. C.

DRAUGHTSMEN:

B. Boden, 58 Glencrest Blvd. Toronto 16, Ontario.
V. Young, 703 Cortex Avenue, Bay Ridges, Ontario.
N. Lade, 299 Jasper Avenue, Oshawa, Ontario.

McPHAR GEOLOGICAL LIMITED

Ashton W. Mullan
Geologist

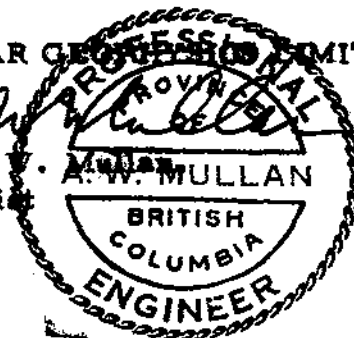

Dated: November 6, 1972

STATEMENT OF COST

Isco Explorations Ltd.
Summers Creek Valley
Similkameen Mining Division, B.C.

Crew: G. Trefenanko - D. Irish

Total Line Miles - 27.27

20 miles @ \$380.00 per line mile	\$ 7,600.00
7.27 miles @ \$350.00 per line mile	2,617.20
	<u>\$10,217.20</u>

26 1/2 days Operating	@ \$198.25/day	5,253.62
1/2 day Preparation)		
2 days Travel)		
1 1/2 days Bad Weather) 4 1/2 days	@ \$100.00/day	450.00
1/2 day Standby)		
2 days Off		N. C.

Expenses

Bus Fare	6.05	
Vehicle Expense	194.21	
Truck Rental (Avis)	421.93	
Meals and Accommodation	1,863.61	
Supplies	2.98	
Telephone and Telegraph	5.43	
	<u>2,494.21</u>	
+ 10%	249.42	
		2,743.63

Extra Labour	\$1,475.00	
+ 20%	<u>295.00</u>	
		1,770.00

\$10,217.25

Declared before me at the City
of Vancouver, in the
Province of British Columbia 10
day of January 1973

McPHERSON GEOPHYSICAL LIMITED

Ashton W. McPherson
Geologist
ENGINEER

Dated: November 6, 1972
Sub-mining Recorder

CERTIFICATE

I, Ashton W. Mullan, of the City of Vancouver, in the Province of British Columbia, hereby certify:

1. That I am a geologist and a fellow of the Geological Association of Canada with a business address at Suite 811, 837 West Hastings Street, Vancouver, B. C.

2. That I am registered as a member of the Association of Professional Engineers of the Provinces of Ontario and British Columbia.

3. That I hold a B.Sc. degree from McGill University.

4. That I have been practising my profession as a geologist for about twenty years.

5. I have no direct or indirect interest, nor do I expect to receive any interest directly or indirectly, in the property or securities of Iso Explorations Ltd., or any affiliate.

6. The statements made in this report are based on a study of published geological literature and unpublished private reports.

7. Permission is granted to use in whole or in part for assessment and qualification requirements but not for advertising purposes.

Dated at Toronto

This 6th day of November 1972

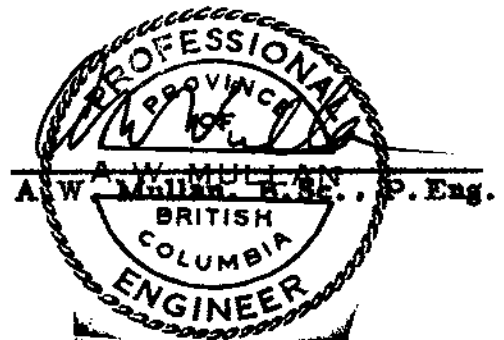

CERTIFICATE

I, Marion A. Goudie, of the City of Toronto, Province of Ontario, do hereby certify that:

1. I am a geologist residing at 739 Military Trail, West Hill, Ontario.
2. I am a graduate of the University of Western Ontario with a B.Sc. Degree (1950) in Honours Geology.
3. I am a member of the Geological Society of America.
4. I have been practising my profession for 23 years.
5. I have no direct or indirect interest, nor do I expect to receive any interest directly or indirectly, in the property or securities of Iso Explorations Ltd., or any affiliate.
6. The statements made in this report are based on a study of published geological literature and unpublished private reports.
7. Permission is granted to use in whole or in part for assessment and qualification requirements but not for advertising purposes.

Dated at Toronto

This 6th day of November 1972

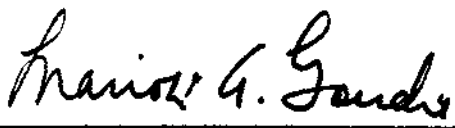

Marion A. Goudie, B.Sc.

INDUCED POLARIZATION
AND
GEOLOGIC SECTION
FROM
BRITISH COLUMBIA
DISSEMINATED SULPHIDES
BELL OREBODY
LINE-22N

—●— DIPOLE-DIPOLE ARRAY, X=200Ft, N=1
-o--o- POLE-DIPOLE ARRAY, X=200Ft, N=1
(REMOTE ELECTRODE - WEST)

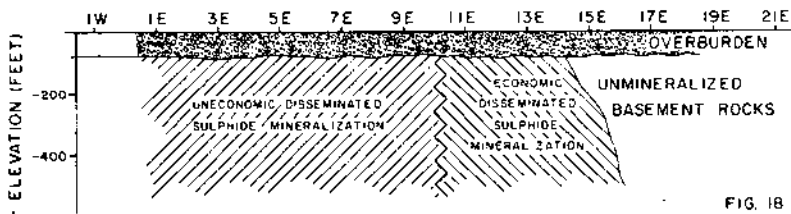
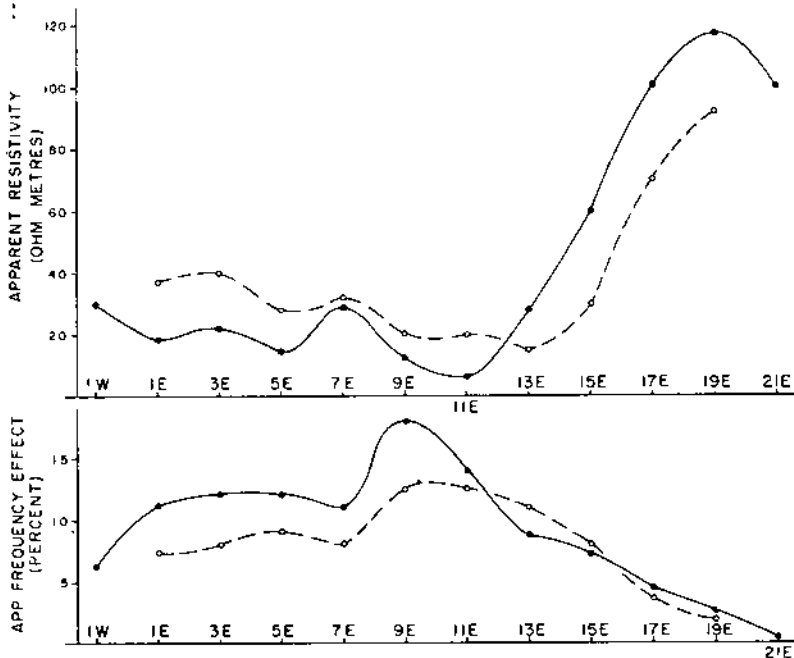
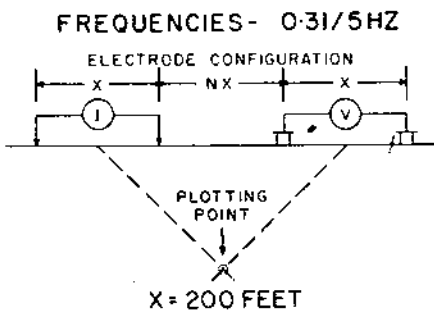

FIG. 18

INDUCED POLARIZATION
AND
GEOLOGIC SECTION
FROM
BRITISH COLUMBIA
DISSEMINATED SULPHIDES
BELL OREBODY
LINE-22N

INDUCED POLARIZATION
AND
GEOLOGIC SECTION
FROM
BRITISH COLUMBIA
DISSEMINATED SULPHIDES
BELL OREBODY
LINE-22N



	0	2E	4E	6E	8E	10E	12E	14E	16E	18E	20E	22E
$\rho/2 \text{ ft (OHM FEET) APP.}$												
$[0.52 X \rho \text{ APP (OHM-METRES)}]$												
N-1		9.3	11	6.9	16	5.9	2.6	14	30	51	61	46
N-2		6.9	13	11	4.8	2.9	2.6	4.8	11	37	44	51
N-3		8.9	12	14	(5.6)	(2.5)	7.2	5.6	8.3	8.7	20	45
N-4		11	8.4	14	(6.7)	NR	NR	9.4	2.9	11	(5.7)	18

	0	2E	4E	6E	8E	10E	12E	14E	16E	18E	20E	22E
FREQUENCY EFFECT APP												
N-1		11	12	12	11	18	14	8.8	7.8	4.7	3.3	10.7
N-2		12	9.3	12	(5.6)	14	9.9	(1.5)	(1.6)	13	7.6	3.2
N-3		7	11	12	NR	8.9	(7.4)	7.7	8.9	11	9.6	5.3
N-4		11	10	12	NR	NR	NR	11	9.3	(7.4)	9.8	9.3

	0	2E	4E	6E	8E	10E	12E	14E	16E	18E	20E	22E
METAL FACTOR APP												
N-1		1200	1070	1800	820	3000	5700	605	262	93	54	15
N-2		1740	(695)	1090	(510)	2890	3470	5720	3340	1173	207	73
N-3		780	925	905	NR	(7550)	11030	1480	1070	1338	465	119
N-4		1070	1230	840	NR	NR	NR	1160	320	657	(1720)	505

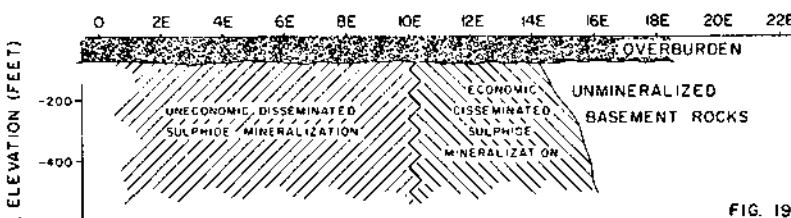

FIG. 19



The Application of the Induced Polarization Method at Brenda Mines, British Columbia

B. K. FOUNTAIN, Geophysicist,
Noranda Exploration Company, Ltd.,
Toronto, Ont.

ABSTRACT

High metal prices and advanced technology in open-pit mining methods have resulted in considerable interest in the development of large, low-grade mineral deposits. Brenda Mines Limited is presently testing such a deposit of copper-molybdenum mineralization near Penticton, British Columbia.

The mineralization of economic interest at Brenda has a total metallic sulphide content of between 1 and 1.5 per cent. This sulphide content approaches the limits of detectability of standard geophysical methods. However, due to a favourable geological environment, it has been possible to utilize the Induced Polarization Method to outline the mineralization at the Brenda property.



DAVID K. FOUNTAIN graduated with a B.A.Sc. degree in engineering physics (geophysics option) at the University of Toronto. He has had experience in all phases of geophysics, both ground and airborne, carrying out exploration work throughout Canada as well as in the United States, Mexico, West Africa and Ireland. Prior to joining Noranda Mines Limited in 1964 as geophysicist, he worked with Pan American Petroleum Corporation, and did some geophysical contracting, including work for the United Nations.

THE PAPER WAS PRESENTED at the 69th Annual General Meeting of the Institute, Ottawa, 1967. It will appear in the 1968 Transactions.

KEYWORDS IN THIS PAPER: Induced polarization method, Geophysical prospecting, Brenda Mines Ltd., Copper, Molybdenum, Mine geology.

Introduction

THE INDUCED POLARIZATION Method of geophysical surveying was originally developed as a tool to detect disseminated metallic sulphide mineralization. When electronic-conducting sulphide minerals are present within ionic-conducting rock materials, the ground is polarizable and the I.P. method can be applied. The lower limit of volume per cent sulphide necessary to produce a recognizable I.P. anomaly will vary with the geometry and geologic environment of the source and the method of executing the survey. However, a rough figure of between 0.5 and 2.0 per cent metallic sulphide by volume, under most conditions, provides a fairly good "rule of thumb" for this lower limit.

In recent years, higher metal prices and advanced technology in mining methods have resulted in exploration for, and the re-evaluation of, metallic sulphide deposits containing grades of mineralization too low to be of economic interest ten years ago. In many cases, the concentration of mineralization involved approaches the limits of detectability by geophysical methods.

At the present time, Brenda Mines Limited is testing such a deposit of copper-molybdenum mineralization near Penticton, British Columbia. At Brenda, the total metallic sulphide content of the deposit is between 1 and 1.5 per cent by weight and less than 1 per cent by volume.

History and Geology of the Brenda Property

The property of Brenda Mines Limited is located in the Osoyoos Mining Division, approximately 14

miles northwest of Peachland, British Columbia. The presence of copper-molybdenum mineralization on the property has been known for many years. It is referred to in Memoir 243 of the Mines and Geology Branch of the Canada Department of Mines and Resources (1947). Work was also carried out in 1955, 1956 and 1957 which indicated widespread mineralization.

The mineralized area of interest at Brenda lies within a granodiorite host rock. The contact between the granodiorite and the Nicola volcanics lies approximately 2,000 feet to the west. The copper-molybdenum metals are present for the most part as chalcopyrite and molybdenite. The total metallic sulphide mineralization is largely restricted to the above-mentioned chalcopyrite and molybdenite, with minor pyrite and some very minor pyrrhotite. The chalcopyrite and molybdenite occur almost entirely in association with quartz and potassium feldspar as fracture fillings, and very little mineralization has invaded or been disseminated in the host rock. The oxidation is shallow, with no evidence of extensive alteration, weathering or breakdown of sulphide minerals.

The granodiorite itself is very fresh, with alteration restricted to the walls of fractures or faults. The three principal strike directions of these fractures are approximately north, N 60°E and N 50°W. The concentration of mineralization is largely a function of the fracture density.

Induced Polarization Surveys

A limited induced polarization survey was carried out on the Brenda property in 1957. On the basis of the results of this work, a more complete survey was carried out

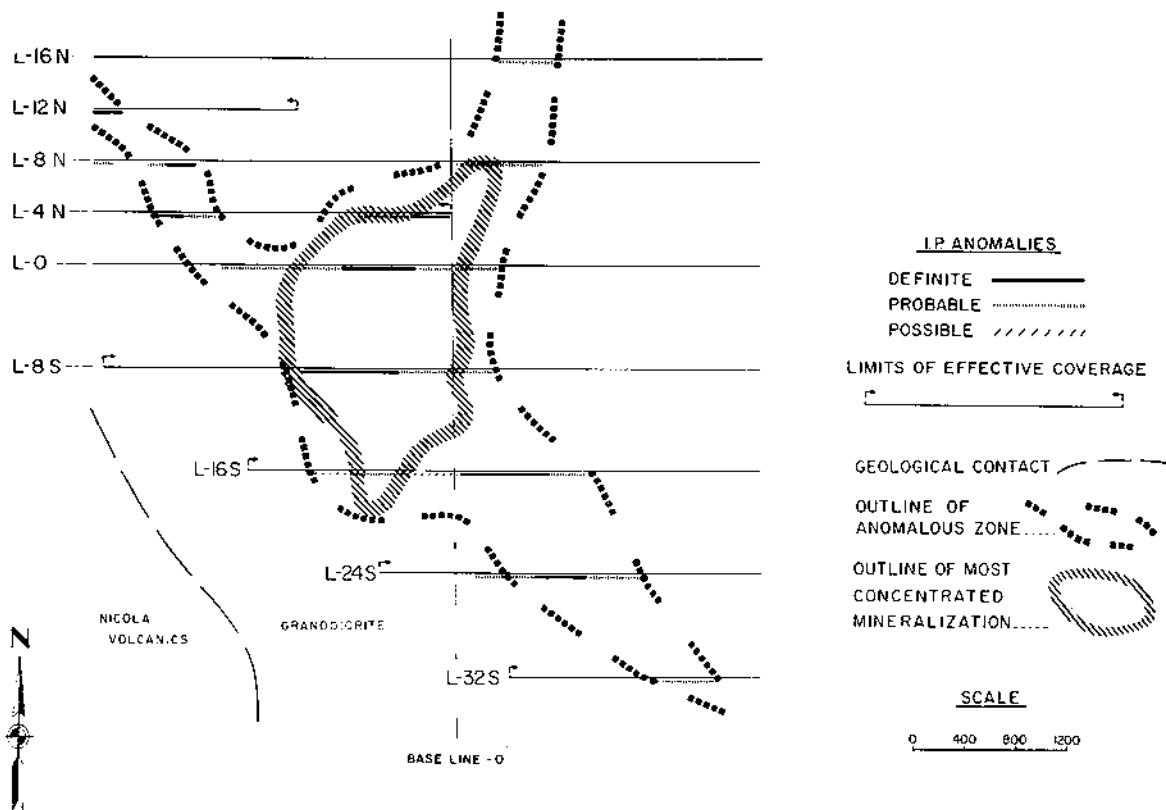

Figure 1.—I.P. Survey at Brenda Mines, 1965-1966.

during 1965 and 1966 as part of a program to re-evaluate the property. The survey, in both cases, was carried out under contract by McPhar Geophysics, employing the variable-frequency method of measuring the I.P. response.

The 1957 survey was one of the first I.P. surveys employing the variable-frequency method to be carried out in Canada. Since that time, substantial advances have been made in instrument development, especially in regard to instrument drift, proper choice of frequencies, power and the general reliability of measurement of the I.P. effect. In spite of the limitations of the older I.P. equipment, a study of the results of the 1957 survey indicated a weak response from the areas of mineralization. This response is diagnostic, due to the over-all low I.P. background of the granodiorite. The low total sulphide content of the deposit would give, at best, a weak I.P. response, and therefore these weak anomalies are considered significant.

On the basis of this, a substantial I.P. program was planned for 1965 and 1966. This work employed the dipole-dipole electrode configuration, with electrode dipoles of 400 feet, and involved reading four dipole separations. The choice of the 400-foot electrode dipoles was based on the fact that mineralization of the over-all grade of that at

Brenda would have to occur in large volumes to be of economic interest. This electrode separation would measure the I.P. response from the metallic sulphides contained in a 400-foot section along the line, as well as giving a response from depth. It should be noted here, however, that the use of large electrode dipoles will be biased against detecting narrow sources, even if they

are of more concentrated mineralization.

Discussion of I.P. Results

The results of the induced polarization survey in the main mineralized zone are indicated in Figure 1, a plan map of the area. The vertical projections of the I.P. anomalies are indicated by solid or dashed

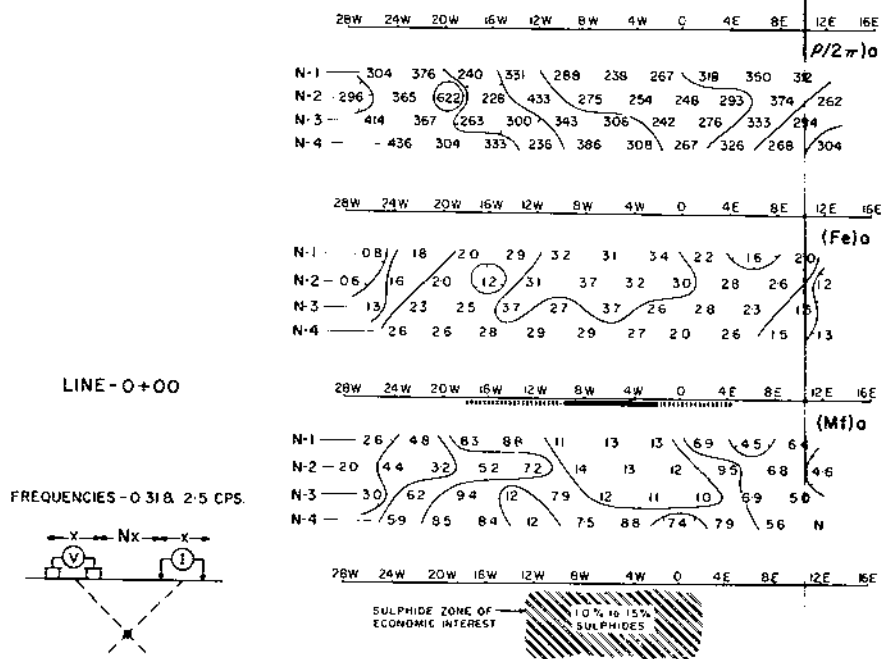

Figure 2.—Induced Polarization and Drilling Results.

lines, depending upon their distinctiveness. The limits of effective coverage along the traverse lines are indicated by bracket-arrows. Where these do not occur, it indicates that the line extends beyond the limits of the diagram area. All the lines indicated in *Figure 1* were surveyed with 400-foot electrode dipoles except for line 4N and line 12N, which were surveyed with 200-foot electrode dipoles to better evaluate the narrow zone to the northwest.

The over-all anomalous I.P. zone is also outlined in *Figure 1*. Superimposed on the I.P. zone is the approximate outline of the concentration of mineralization as indicated by the drilling to date. It is important to note that this outline is based upon an economic cut-off which is partly determined by mining methods. In many cases, it does not indicate a sharp discontinuity in the presence of metallic sulphides, the source of the I.P. response.

It can be seen that the anomalous I.P. zone fits very closely to the outline of the concentrated mineralization. The narrow northwest extension has been joined to the main zone, although the I.P. results there suggest a different character of source from that encountered in the main zone. Insufficient drilling has been carried out to accurately confirm it, but the source of this anomaly may be a mineralized shear zone, although it would not be of economic interest.

The results of the I.P. survey

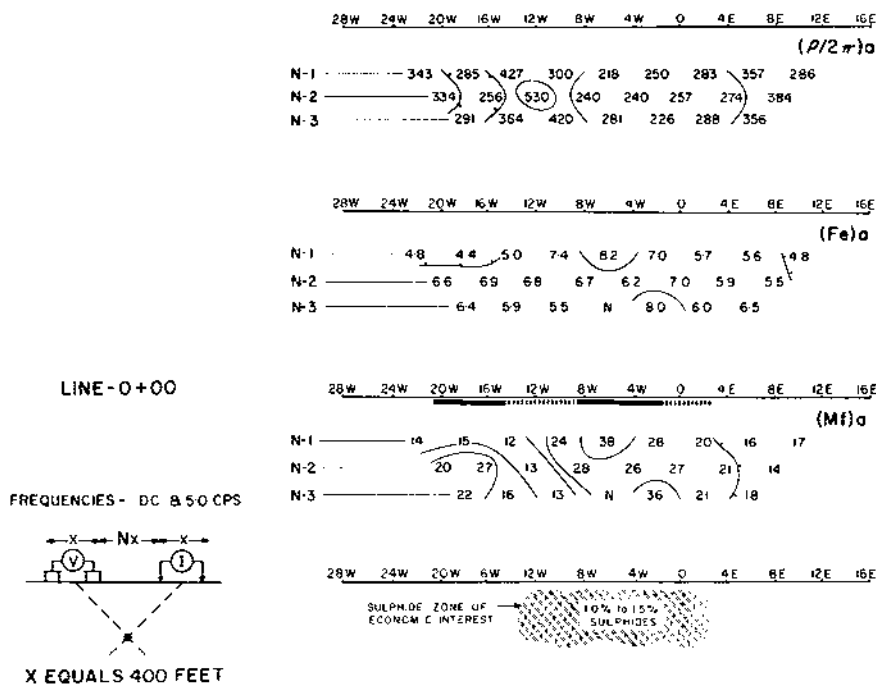

Figure 3.—Induced Polarization and Drilling Results.

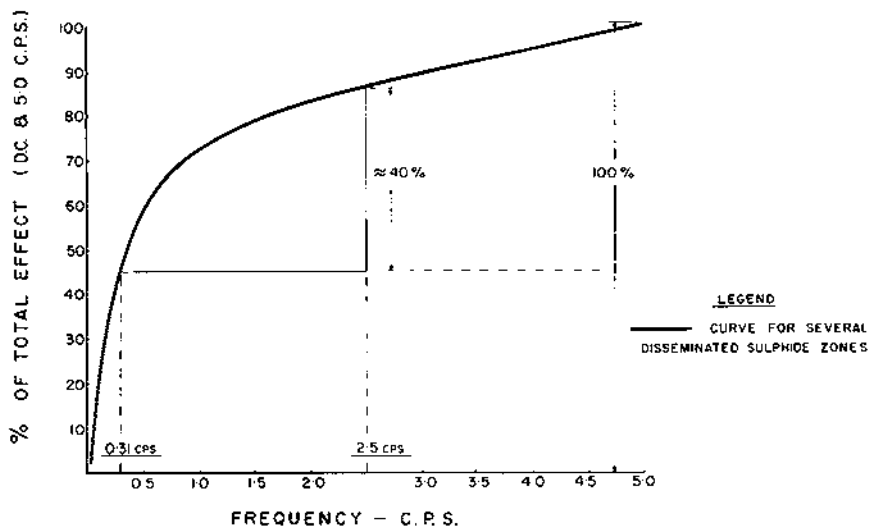

Figure 4.—Frequency Spectra for I.P. Field Results.

indicate a rather sharp cut-off of the mineralization to the west; to the east, the cut-off is more gradual. This is in general agreement with the geology. Mineralization does correlate with the northeast and southeast extensions of the I.P. zone, but insufficient drilling has been carried out to determine its economic significance.

Figure 2 presents the I.P. results for line 0+00 across the zone of mineralization. The measured results are plotted in the "pseudo-section" form commonly employed in the variable-frequency method. This method of plotting is indicated in the lower left-hand corner of the diagram. It should be mentioned here that the sectional plot does not represent an electrical cross section of the ground. The patterns

developed from the observed readings can be interpreted by comparison with expected patterns obtained from computer programs, model studies and previous experience. On the right and across the top of *Figure 2* are the results of the measurement of the Apparent Resistivity in units of $\rho/2\pi$ ohm-feet. Beneath these are the results of the measurement of the Apparent Per Cent Frequency Effect — the measurement of the induced polarization. The third and lower section presents the values of the Apparent Metal Factor. The metal factor is obtained by normalizing the per cent frequency effect for varying resistivities, and is a useful interpretative aid. On this section, the I.P. anomaly has been indicated by a solid and dashed line, as on *Figure 1*. At the extreme bottom of the diagram is a schematic section of the sulphide zone of economic interest.

The I.P. anomaly centered at 4W to 8W and extending from 4E to 18W, although weak, correlates very well with the mineralized zone. The resistivities are quite uniform, with a slight low correlating with the area of interest. The per cent frequency effects are low; anomalous values being only 1 to 1.5 units over background.

When the magnitude of the I.P. response is low, as is the case in a situation like that at Brenda, spurious I.P. effects due to electrical noise, either man-made or natural, can create problems. In most cases, where the target sulphide mineralization is more concentrated, this noise can easily be kept to a level much below the significant anomalous response expected. One method employed at Brenda to test the validity of questionable anomalies was to resurvey the area con-

cerned using a different frequency interval. If the anomaly is caused by metallic mineralization, then there will be a diagnostic relationship for the difference in I.P. response for the two frequency intervals employed. Figure 3 shows the results of resurveying the anomalous area of line 0+00 utilizing D.C. frequencies and 5.0 cps. The results presented in Figure 2 for line 0 were obtained utilizing frequencies of 0.31 and 2.5 cps. From Figures 2 and 3, it can be seen that the anomalous I.P. response for

frequencies of 0.31 and 2.5 cps is approximately 40 per cent of the response obtained utilizing D.C. and 5.0 cps.

Figure 4 presents a plot of the variation of I.P. response with various frequency intervals, assuming the response for the D.C. frequency interval and 5.0 cps to be 100 per cent. This curve is drawn from measurements made over several disseminated sulphide deposits. It can be seen that the change in response of approximately 40 per cent obtained from the results on

line 0 agrees with the expected change obtained from the curve.

The results of the I.P. survey on line 8S across the mineralized zone are presented in Figure 5. Again, the I.P. anomaly correlates very well with the outline of the zone of concentrated sulphides. The edge of the anomaly is quite sharp on the west side, but less distinct to the east, suggesting a more gradual decrease in the sulphide mineralization in this direction. A portion of the section of line 8S presented in Figure 5 was also covered by the I.P. survey carried out in 1957. The results from the older survey are seen in Figure 6. This work was carried out using 200-foot dipoles, so the scale in Figure 6 is twice that in Figure 5. The limit of coverage did not extend far enough to delimit the eastern edge of the anomaly, but there is fairly good correlation between the anomalies obtained on the two surveys. The over-all magnitude of the results of the 1957 work are greater than those obtained in the recent work. This is due to the use of a large frequency interval as well as some basic differences in instrumentation.

There are several aspects of the form of occurrence of the mineralization that have contributed to the successful application of the I.P. method at the Brenda property. In normal field applications, the I.P. method does not differentiate between pyrite and the economically important sulphides such as chalcopyrite. Where directly associated with the economic mineralization, pyrite will assist in the detection of the target by both increasing the magnitude of the anomaly (increase total sulphide content) and, in some cases, increasing the actual size of the target sought. At Brenda, the presence of little or no pyrite mineralization, although decreasing the magnitude of the anomaly, does mean that the strongest I.P. anomalies will represent the greatest concentration of economic mineralization. This allows for greater application of I.P. results in planning the drill program.

The granodiorite host rock is fresh, resulting in a uniform and low background I.P. response, and thus the weak but significant anomalous responses can be detected. However, experience has shown that the over-all background I.P. response in the area of the volcanics is so high that it would not be possible to detect the weak Brenda anomaly. This is especially true

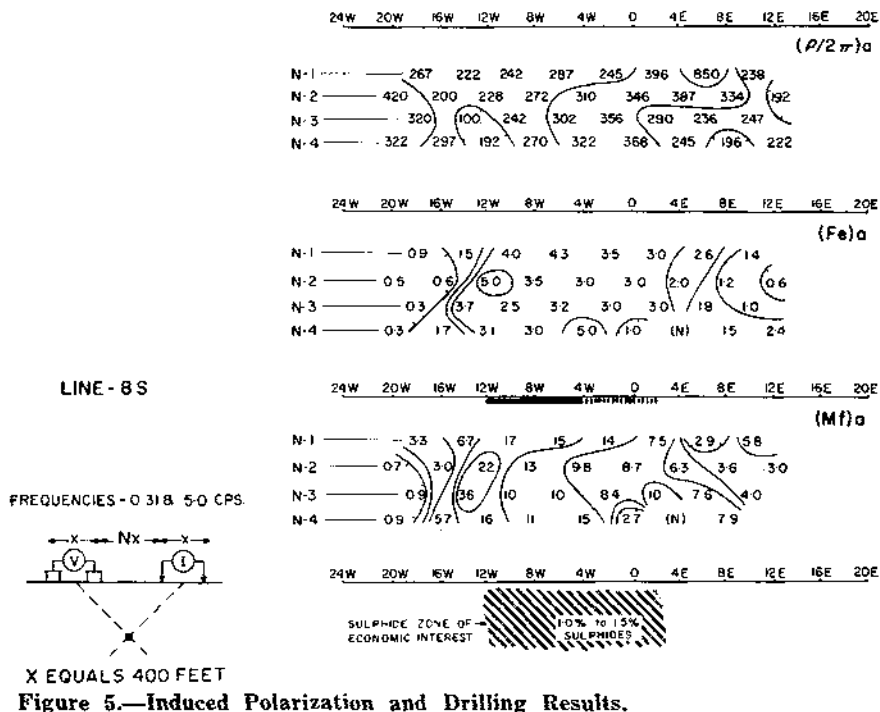

Figure 5.—Induced Polarization and Drilling Results.

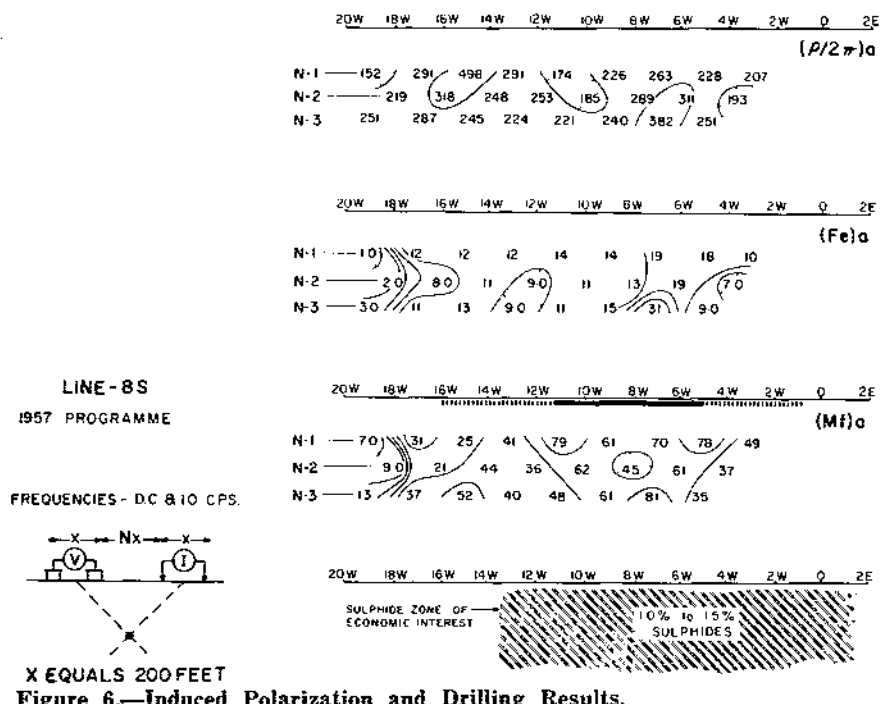

Figure 6.—Induced Polarization and Drilling Results.

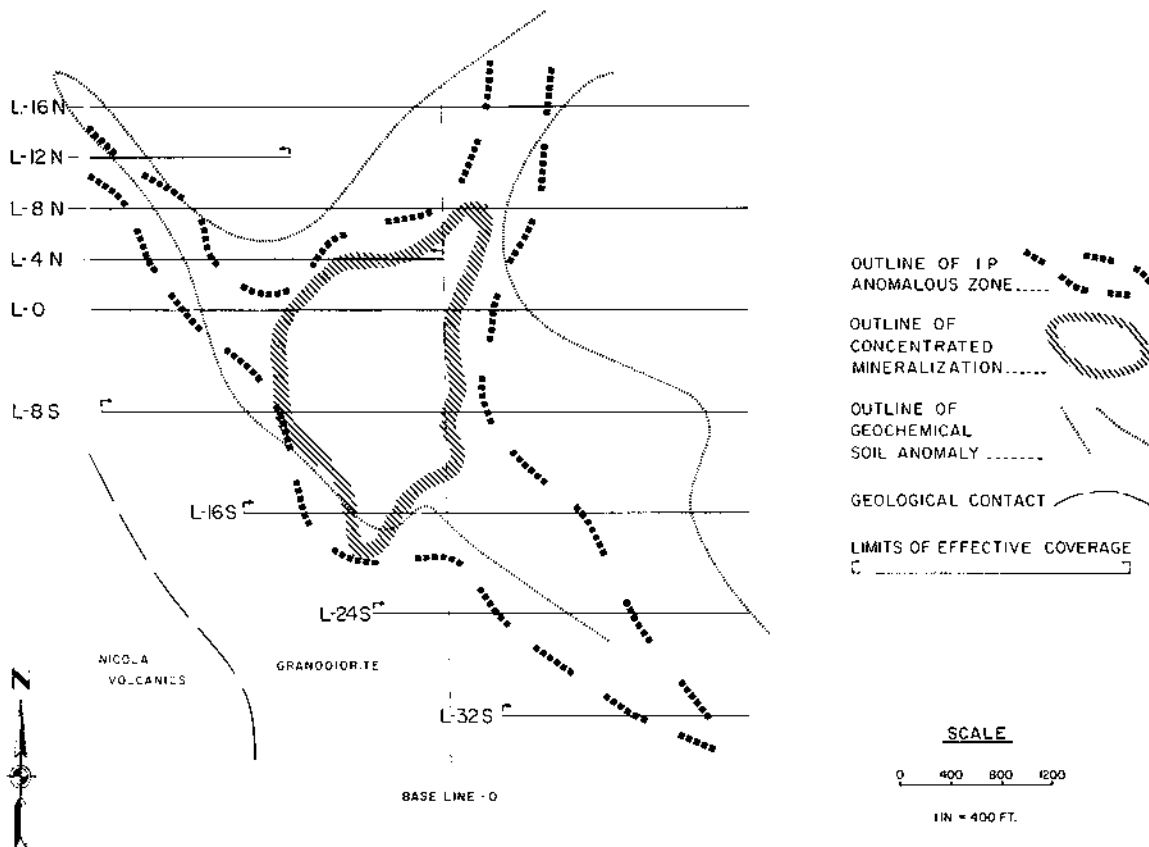

Figure 7.—I.P. - Geochemical Comparison at Brenda Mines.

in the region of the contact between the volcanics and the granodiorite, where I.P. anomalies with magnitudes greater than ten times that of the Brenda mineralization were detected. The source of these anomalies is primarily pyrite, with some magnetite and possibly graphite. These results indicate that the geophysical survey must be planned giving due consideration to the geological environment.

Other Surveys

The Induced Polarization Method was only one of the exploration tools used to evaluate the Brenda prospect. In the earlier programs, limited magnetometer and spontaneous potential surveys were carried out, but proved to be of little assistance. Geochemical programs, both silt and soil sampling, have also been carried out on the property. Figure 7 shows the outlines of the concentrated mineralization, the I.P. anomaly and the soil geochemical anomaly. There is good correlation between the I.P. and geochemical results. In addition, a fracture intensity study of the available outcrop has indicated good correlation with geochemical and I.P. results.

Summary

The results of the work on the Brenda property indicate that the Induced Polarization Method can be successfully applied to explore for and evaluate even very low grade metallic sulphide mineral deposits. The anomalous I.P. response, however, will be small; and the survey must be carried out with a full understanding of the geological situation and the nature of the target sought. This will require a close correlation of geochemical, geological and geophysical information.

The results also indicate that the successful exploration program must consist of close co-operation between the geophysicist and/or geochemist who understands the limitations and capabilities of the method, and the geologist who has a good knowledge of the geological situation.

Acknowledgments

The author wishes to thank both Noranda Exploration Company, Limited and Brenda Mines Limited for permission to present this paper. He would also like to express his appreciation to Chapman, Wood

and Griswold Limited and McPhar Geophysics Limited for their co-operation and assistance in preparing the paper, and to Kennco Explorations, (Canada) Limited for permission to use the data from the 1957 survey.

REFERENCES

- Brant, A. A., "Geophysics and the Exploration for Arizona Porphyry Coppers," *Porphyry Coppers*, Titley and Hicks, University of Arizona Press.
- Chapman, E. P., Jr., unpublished company reports.
- Hallof, P. G., "Proper Choice of Frequencies for Induced Polarization Measurements," S.E.G. Annual Meeting, November, 1965.
- Hallof, P. G., "Variable Frequency Induced Polarization Data Compared with Drilling Results at Four Properties," *Northern Miner*, November 30, 1961.
- Marshall, D. J., and Madden, T. R., "Induced Polarization, A Study of its Causes," *Geophysics*, Vol. XXXIV, pp. 790-816.
- Ney, Charles S., unpublished company report.
- Rogers, George R., "An Evaluation of the Induced Polarization Method in the Search for Disseminated Sulphides," S.E.G., *Mining Geophysics*, Vol. I, Case Histories.
- Rogers, George R., "The Search for Disseminated Sulphides Introduction," S.E.G., *Mining Geophysics*, Vol. I, Case Histories.

(Reprinted from The Canadian Mining and Metallurgical Bulletin, February, 1968)

Printed in Canada

N - 5
N - 4
N - 3
N - 2
N - 1

RESISTIVITY (APP.) IN OHM FEET / 2π

72W 69W 66W 63W 60W 57W 54W 51W 48W 45W 42W 39W 36W 33W 30W 27W 24W 21W 18W 15W 12W 9W 6W 3W 0

METAL FACTOR (APP.)

N - 1
N - 2
N - 3
N - 4
N - 5

72W 69W 66W 63W 60W 57W 54W 51W 48W 45W 42W 39W 36W 33W 30W 27W 24W 21W 18W 15W 12W 9W 6W 3W 0

FREQUENCY EFFECT (APP.) IN %

N - 1
N - 2
N - 3
N - 4
N - 5

BRACKETED NUMBERS INDICATE PICKETS ON GROUND
(87.18W) (58.80W) (51.80E) (38.80W) (36W) (33.78W) (31.18W) (28.80W) (26W) (23.28W) (20.80W) (17.80W) (14.70W) (11.70W)

FREQUENCY EFFECT (APP.) IN %

N - 1
N - 2
N - 3
N - 4
N - 5

N - 5
N - 4
N - 3
N - 2
N - 1

RESISTIVITY (APP.) IN OHM FEET / 2π

72W 69W 66W 63W 60W 57W 54W 51W 48W 45W 42W 39W 36W 33W 30W 27W 24W 21W 18W 15W 12W 9W 6W 3W 0

METAL FACTOR (APP.)

N - 1
N - 2
N - 3
N - 4
N - 5

72W 69W 66W 63W 60W 57W 54W 51W 48W 45W 42W 39W 36W 33W 30W 27W 24W 21W 18W 15W 12W 9W 6W 3W 0

FREQUENCY EFFECT (APP.) IN %

N - 1
N - 2
N - 3
N - 4
N - 5

4166 DWG. NO. - I.P. - 6010-1

ISO EXPLORATIONS LTD.

KALCO VALLEY MINES LTD., (N.P.L.) OPTION,
SUMMERS CREEK VALLEY, TULAMEEN AREA,
SIMILKAMEEN M.D., BRITISH COLUMBIA.

LINE NO. - 1600N

ELECTRODE CONFIGURATION

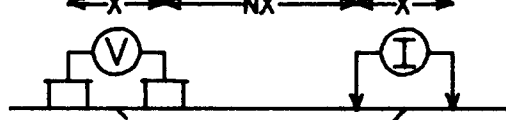

PLOTTING POINT X X = 300FT

SURFACE PROJECTION OF ANOMALOUS ZONES

DEFINITE **————**
PROBABLE **|||||**
POSSIBLE **////**

FREQUENCIES: 0.31-5.0 HZ

DATE SURVEYED: 1916 1972

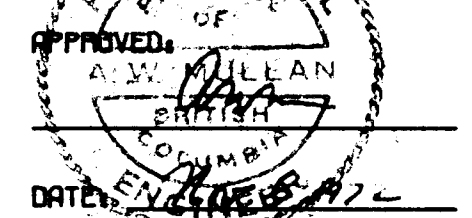

NOTE: CONTOURS AT LOGARITHMIC INTERVALS 1.-1.5-2.-3.-5.-7.5-10

McPHAR GEOPHYSICS

INDUCED POLARIZATION AND RESISTIVITY SURVEY

NOTE: THIS PLOT WAS PRODUCED BY McPHAR COMPUTER DIVISION

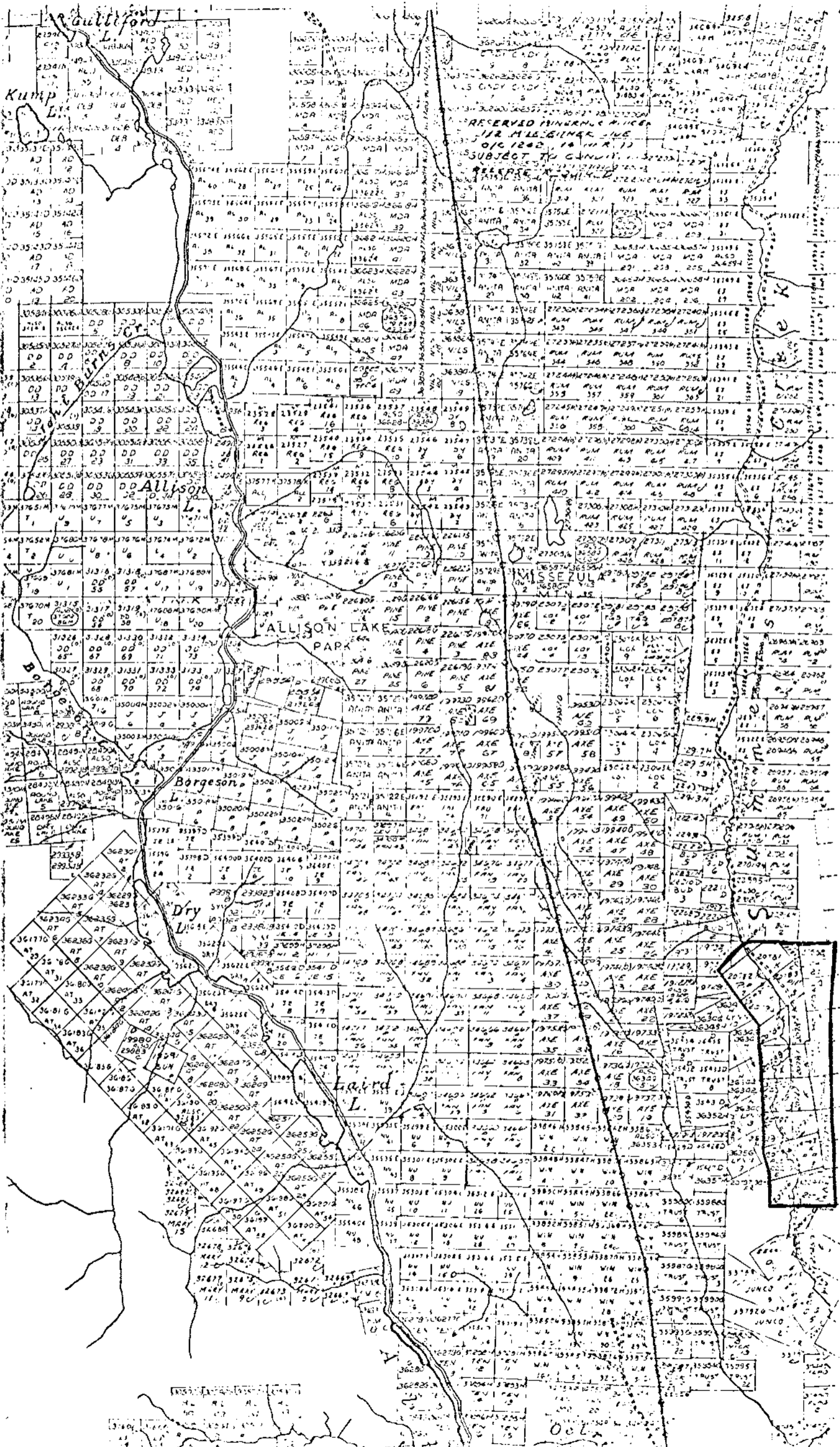

6

5

4

TO EAST SEE MAP 92H/9W

3

RESERVED HIGHWAY ALICE
112 HILLGIMMER AVE
OIC 1242 14 MAR 12
SUBJECT TO CANTON

ALLISON LAKE
PARK

Dry L.

Laird L.

Oct

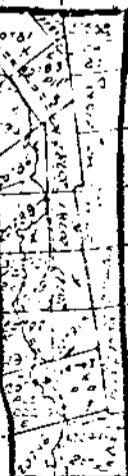

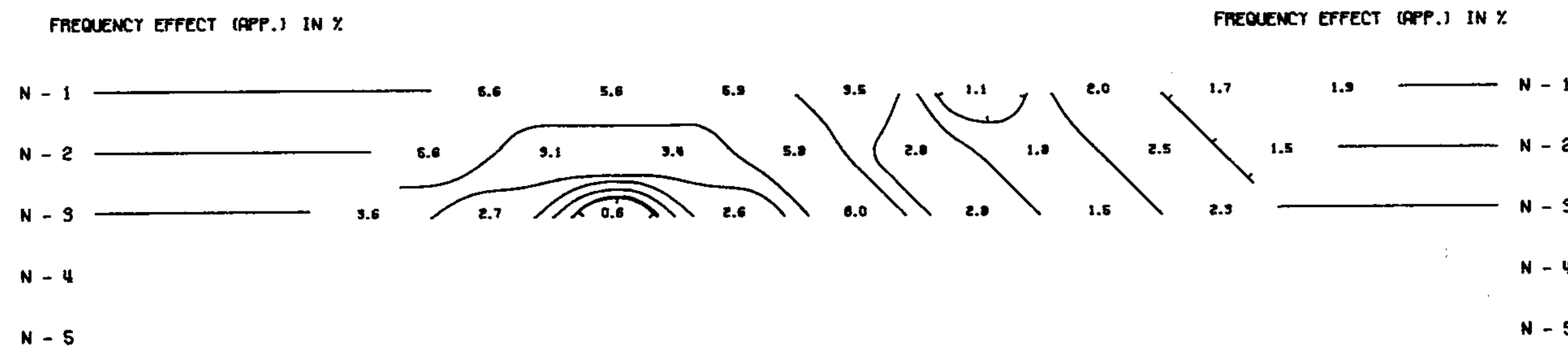
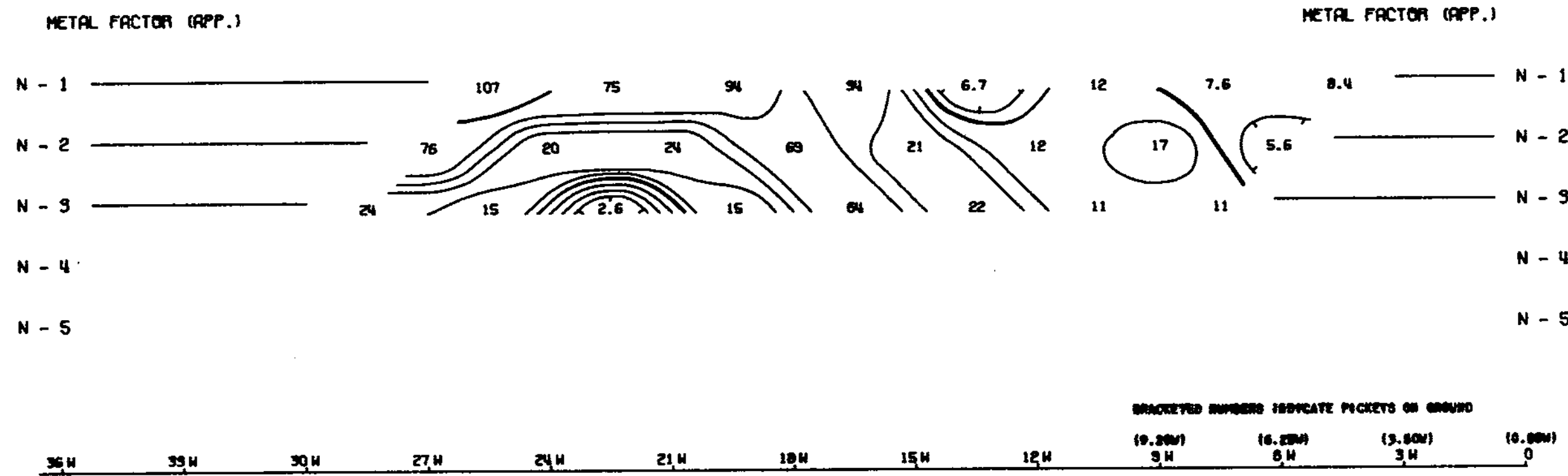
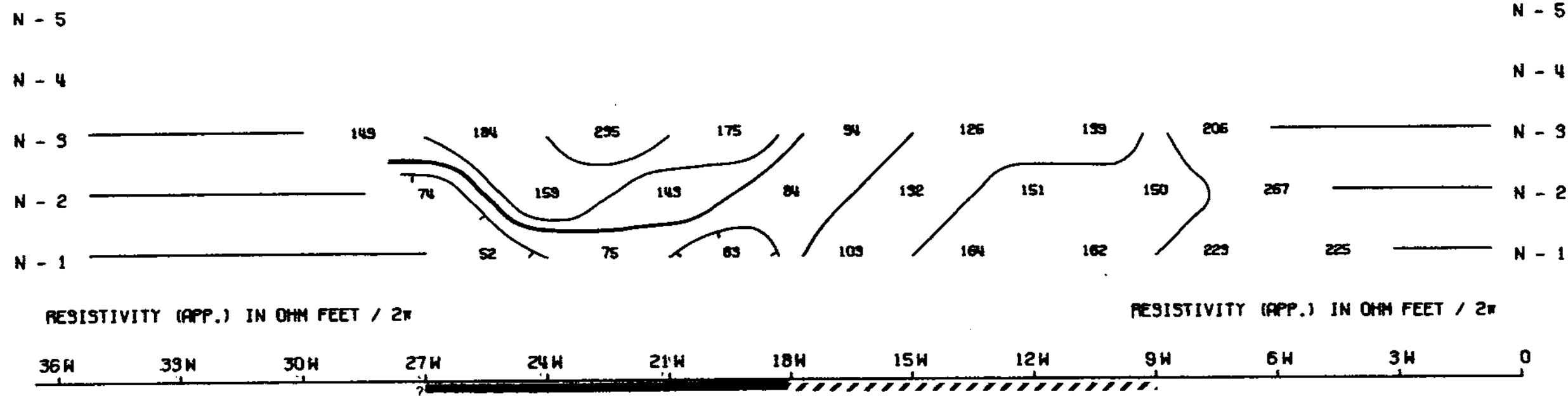

4166 DWG. NO.- I.P.- 6010-30
 ISO EXPLORATIONS LTD.

KALCO VALLEY MINES LTD., (N.P.L.) OPTION,
 SUMMERS CREEK VALLEY, TULAMEEN AREA,
 SIMILKAMEEN M.D., BRITISH COLUMBIA.

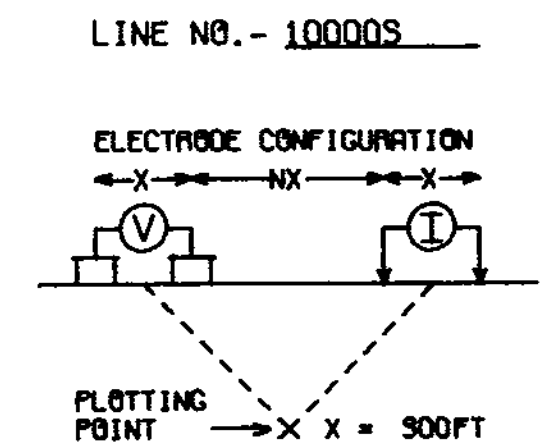

SURFACE PROJECTION
 OF ANOMALOUS ZONES

DEFINITE **—————**
 PROBABLE **|||||**
 POSSIBLE **////**

FREQUENCIES: 0.91-5.0 HZ DATE SURVEYED: SEP 1972

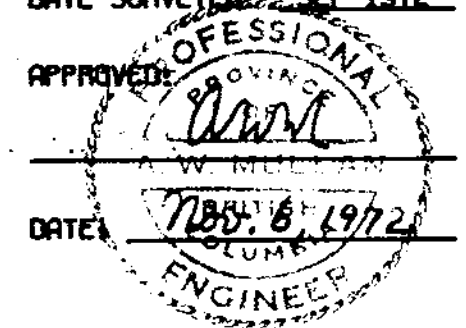

NOTE: CONTOURS AT LOGARITHMIC INTERVALS 1.-1.5-2.-3.-5.-7.5-10

McPHAR GEOPHYSICS
 INDUCED POLARIZATION AND RESISTIVITY SURVEY
 NOTE: THIS PLOT WAS PRODUCED BY McPHAR COMPUTER DIVISION

ISO EXPLORATIONS LTD.

KALCO VALLEY MINES LTD., (N.P.L.) OPTION,
SUMMERS CREEK VALLEY, TULAMEEN AREA,
SIMILKAMEEN M.D., BRITISH COLUMBIA.

LINE NO.- 9600S

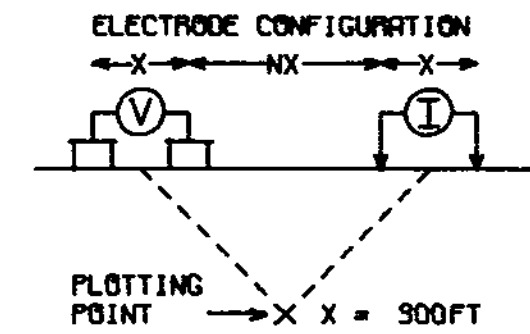

SURFACE PROJECTION
OF ANOMALOUS ZONES
DEFINITE **—————**
PROBABLE **|||||**
POSSIBLE **////**

FREQUENCIES: 0.31-5.0 HZ

DATE SURVEYED: SEP 1972

APPROVED: *[Signature]*
DATE: *Nov. 6, 1972*
ENGINEER

NOTE: CONTOURS AT
LOGARITHMIC INTERVALS
1.-1.5-2.-3.-5.-7.5-10

McPHAR GEOPHYSICS

INDUCED POLARIZATION AND RESISTIVITY SURVEY

NOTE: THIS PLOT WAS PRODUCED BY McPHAR COMPUTER DIVISION

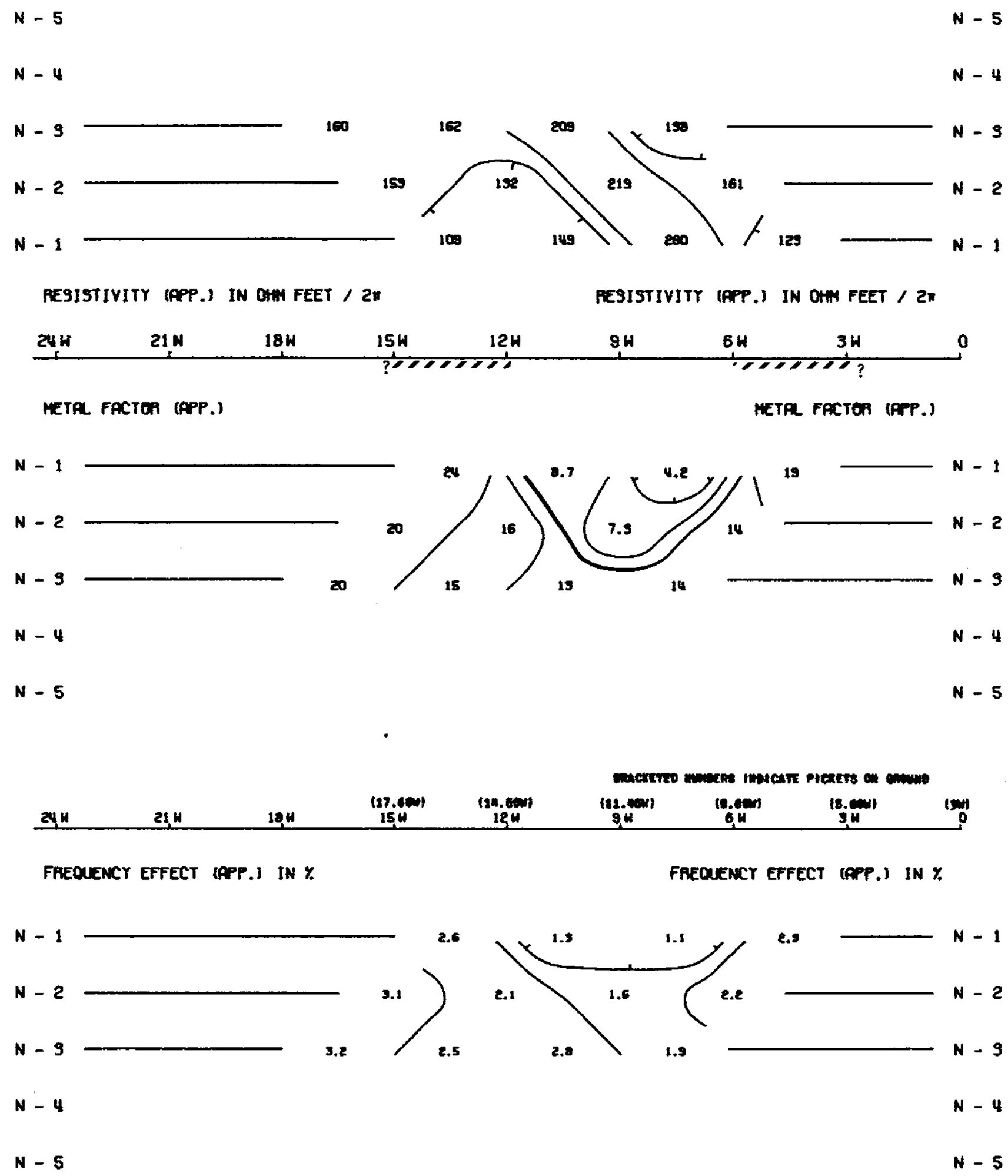

ISO EXPLORATIONS LTD.

KALCO VALLEY MINES LTD., (N.P.L.) OPTION,
SUMMERS CREEK VALLEY, TULAMEEN AREA,
SIMILKAMEEN M.D., BRITISH COLUMBIA.

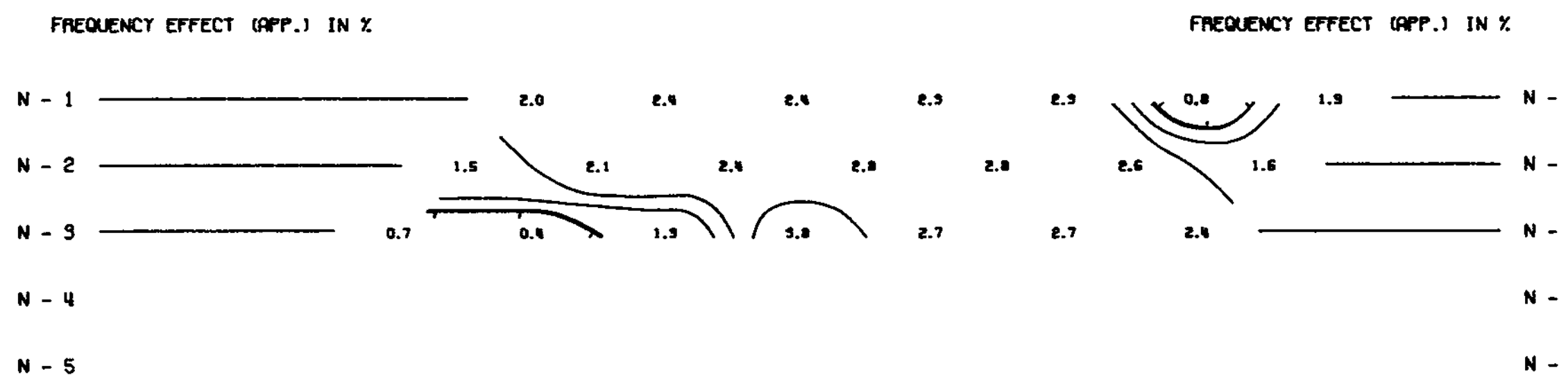
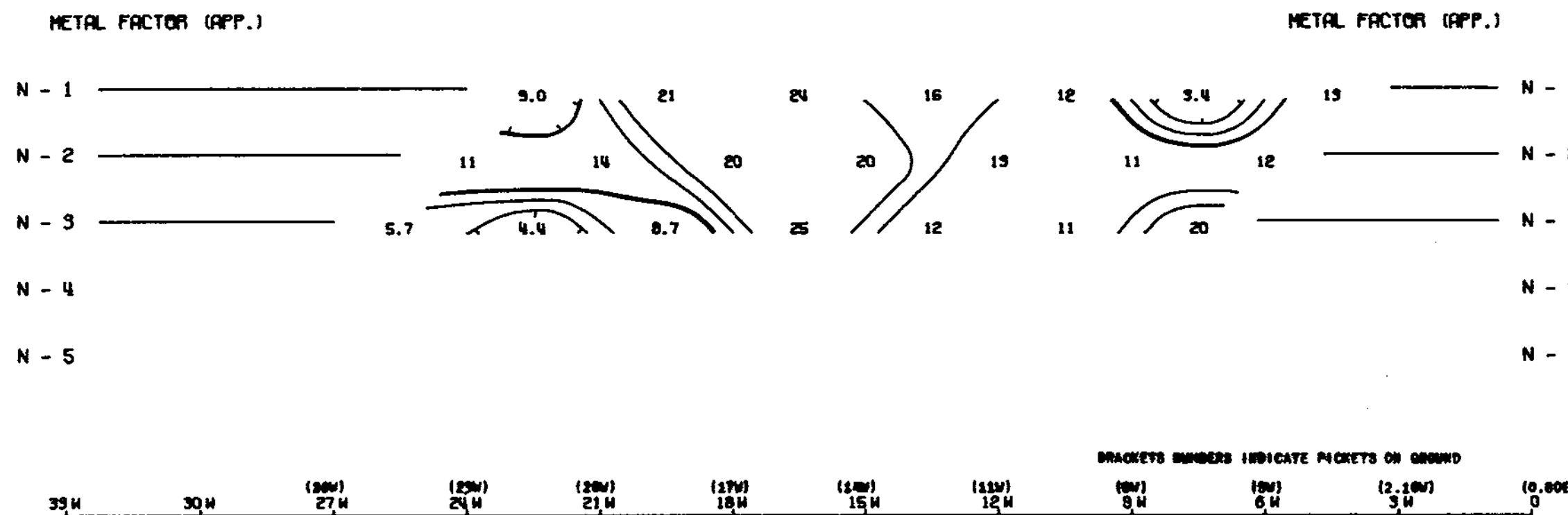
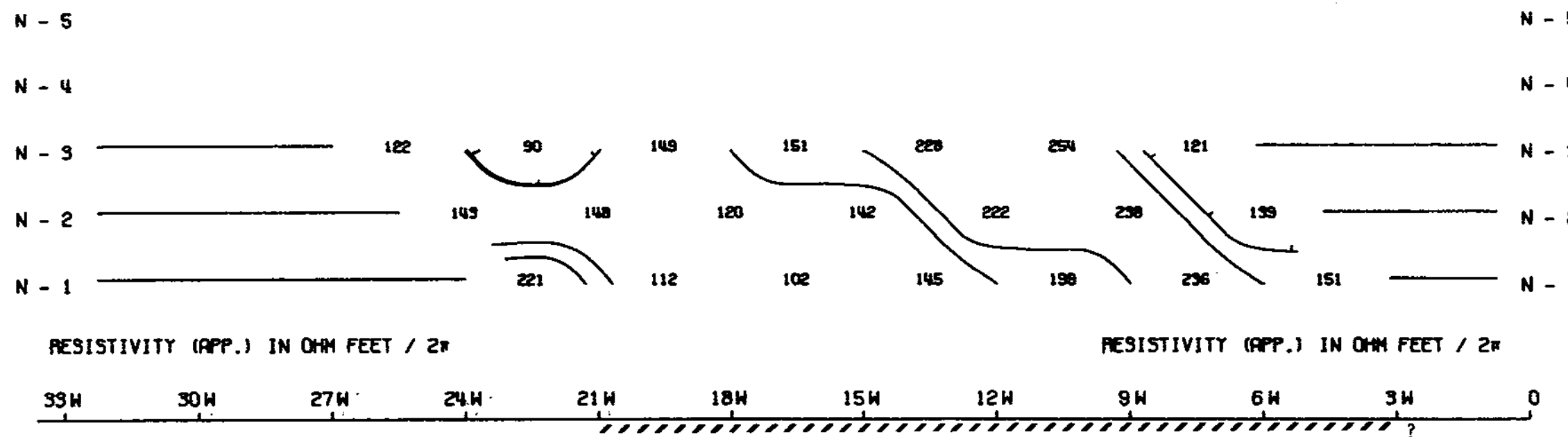

LINE NO. - 92005

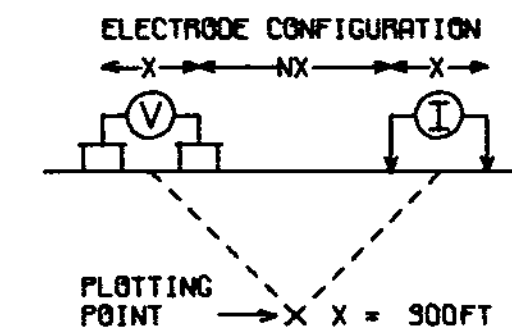

SURFACE PROJECTION OF ANOMALOUS ZONES

DEFINITE

PROBABLE

POSSIBLE

FREQUENCIES: 0.91-5.0 HZ

DATE SURVEYED: AUG 1972

APPROVED:

DATE: Nov 6, 1972

NOTE: CONTOURS AT LOGARITHMIC INTERVALS 1.-1.5-2.-3.-5.-7.5-10

McPHAR GEOPHYSICS

INDUCED POLARIZATION AND RESISTIVITY SURVEY

NOTE: THIS PLOT WAS PRODUCED BY McPHAR COMPUTER DIVISION

ISO EXPLORATIONS LTD.

KALCO VALLEY MINES LTD., (N.P.L.) OPTION,
SUMMERS CREEK VALLEY, TULAMEEN AREA,
SIMILKAMEEN M.D., BRITISH COLUMBIA.

LINE NO. - 8800S

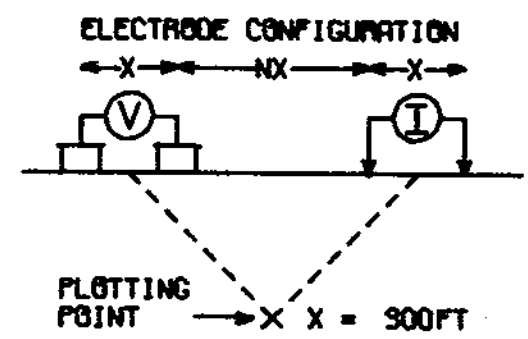

SURFACE PROJECTION
OF ANOMALOUS ZONES
DEFINITE **————**
PROBABLE **|||||**
POSSIBLE **////**

FREQUENCIES: 0.91-5.0 HZ

DATE SURVEYED: Aug 1972
APPROVED: *[Signature]*
DATE: Aug 1972

NOTE: CONTOURS AT
LOGARITHMIC INTERVALS
1.-1.5-2.-3.-5.-7.5-10

McPHAR GEOPHYSICS

INDUCED POLARIZATION AND RESISTIVITY SURVEY

NOTE: THIS PLOT WAS PRODUCED BY McPHAR COMPUTER DIVISION

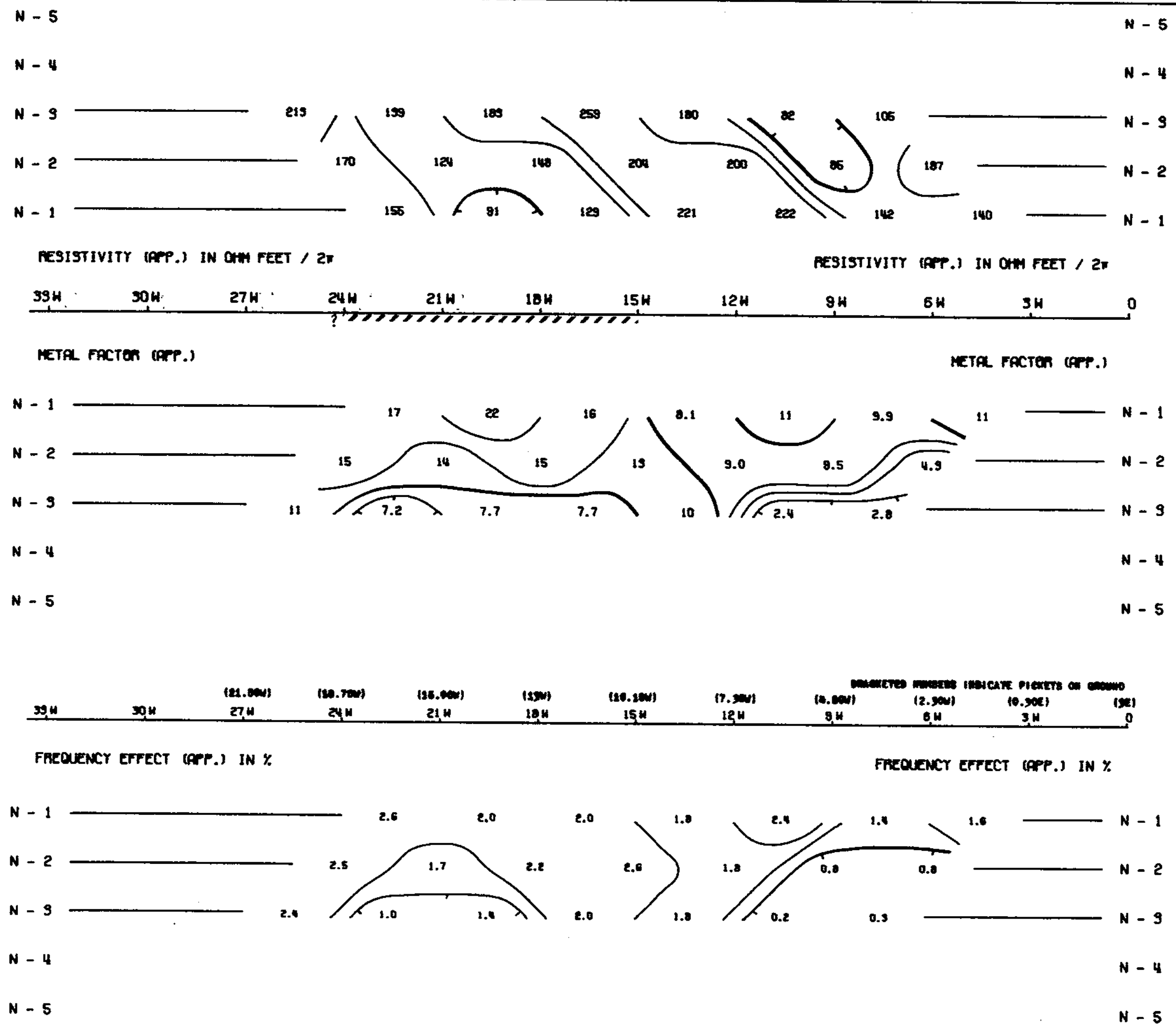

ISO EXPLORATIONS LTD.

KALCO VALLEY MINES LTD., (N.P.L.) OPTION,
SUMMERS CREEK VALLEY, TULAMEEN AREA,
SIMILKAMEEN M.D., BRITISH COLUMBIA.

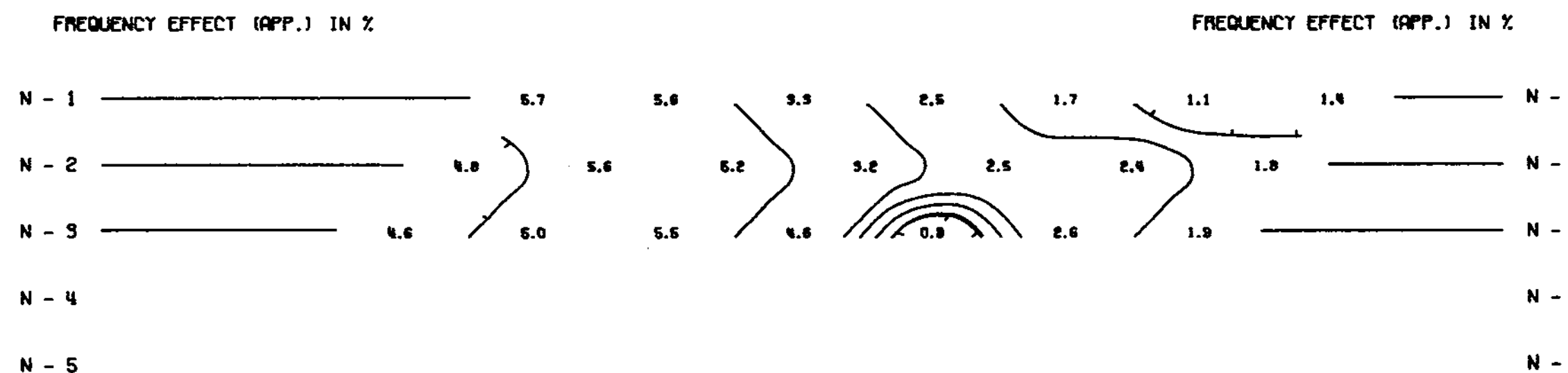
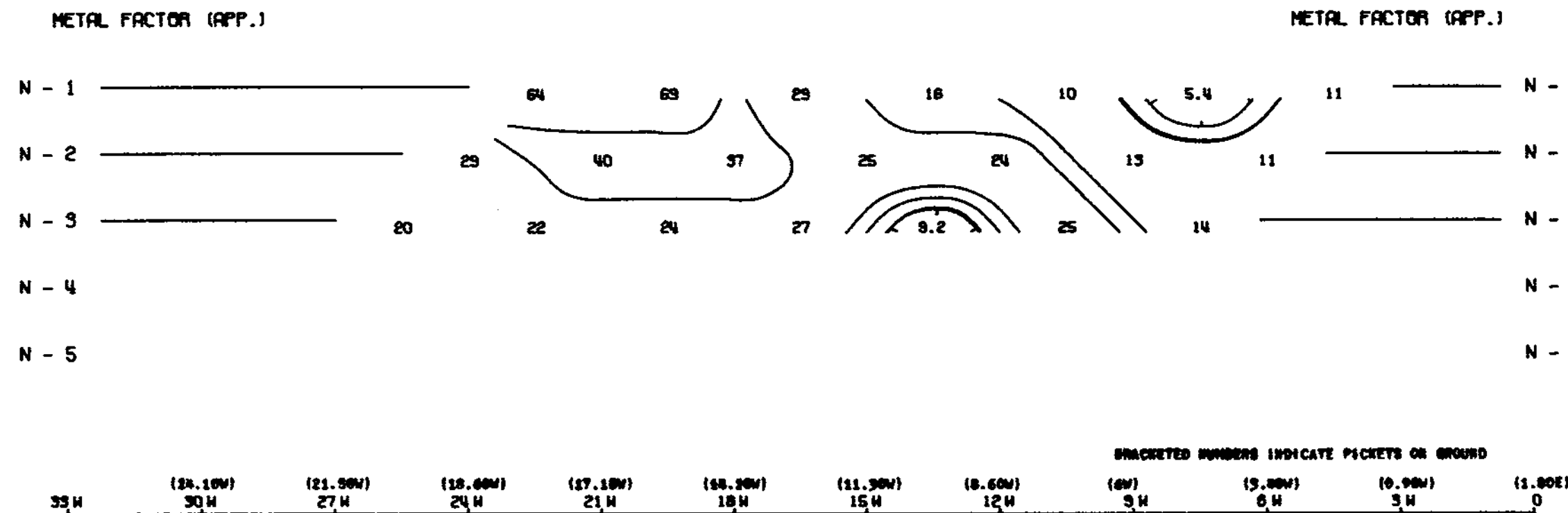
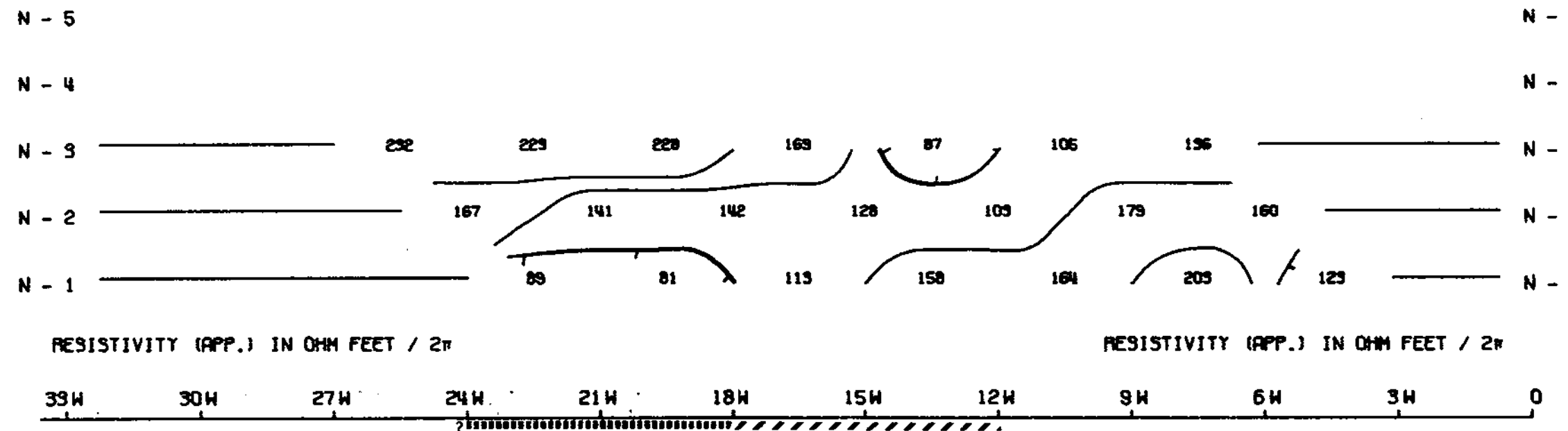

LINE NO. - 8400S

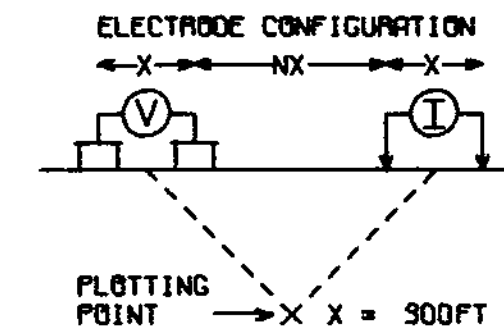

SURFACE PROJECTION OF ANOMALOUS ZONES

DEFINITE **—————**
PROBABLE **|||||**
POSSIBLE **////**

FREQUENCIES: 0.31-5.0 HZ

DATE SURVEYED: AUG 1972

APPROVED: *[Signature]*

DATE: *Nov. 6, 1972*

NOTE: CONTOURS AT LOGARITHMIC INTERVALS 1.-1.5-2.-3.-5.-7.5-10

McPHAR GEOPHYSICS

INDUCED POLARIZATION AND RESISTIVITY SURVEY

NOTE: THIS PLOT WAS PRODUCED BY McPHAR COMPUTER DIVISION

ISO EXPLORATIONS LTD.

KALCO VALLEY MINES LTD., (N.P.L.) OPTION,
SUMMERS CREEK VALLEY, TULAMEEN AREA,
SIMILKAMEEN M.D., BRITISH COLUMBIA.

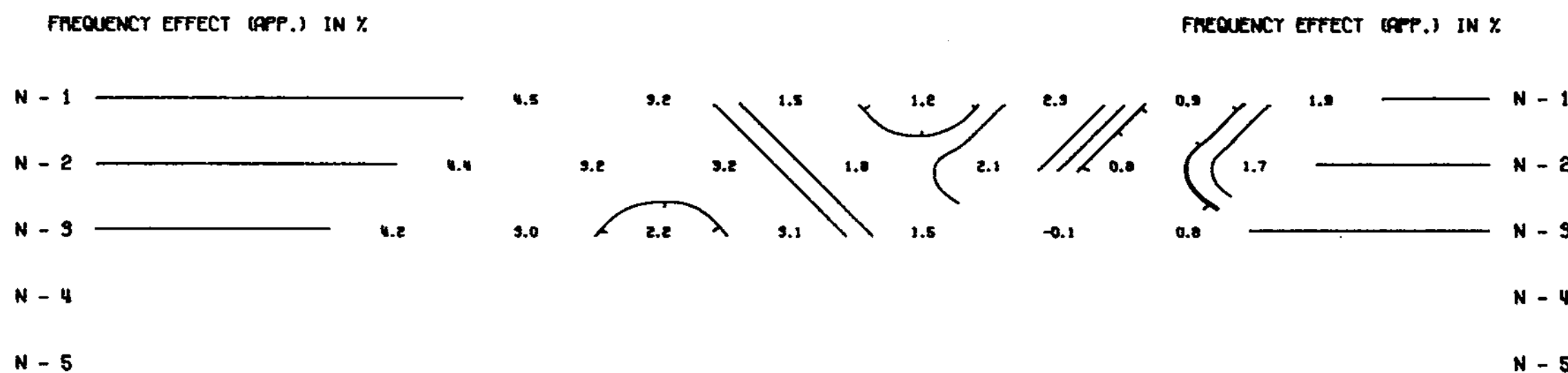
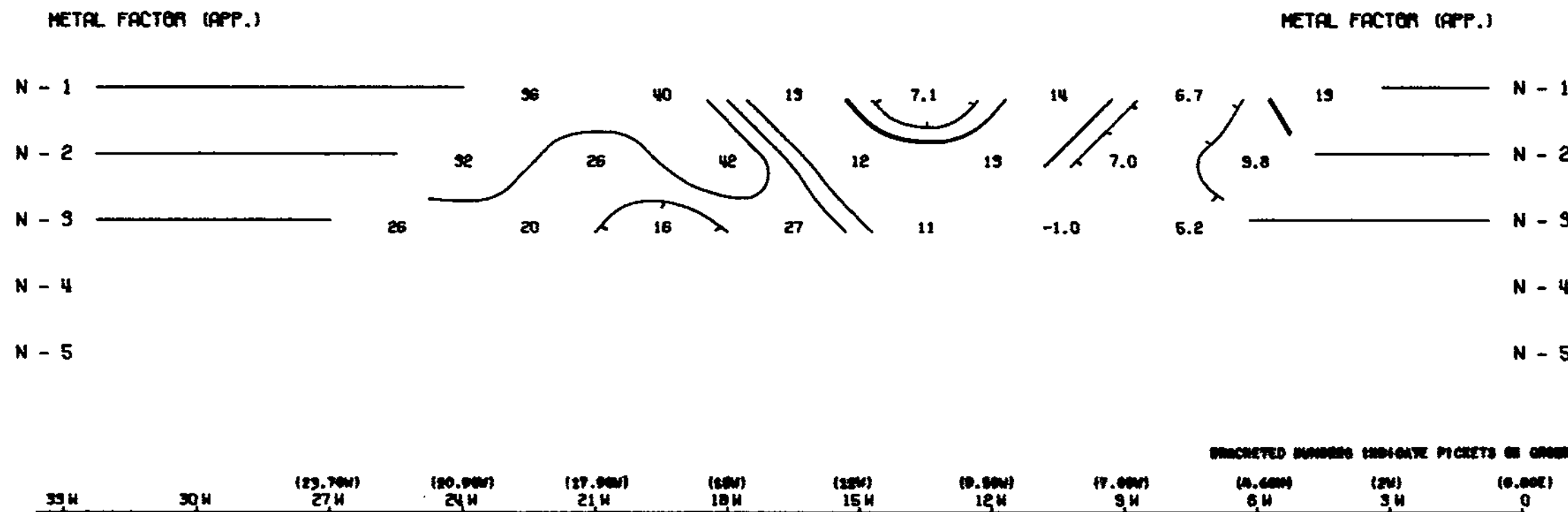
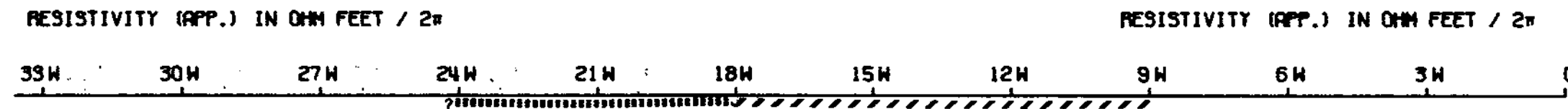
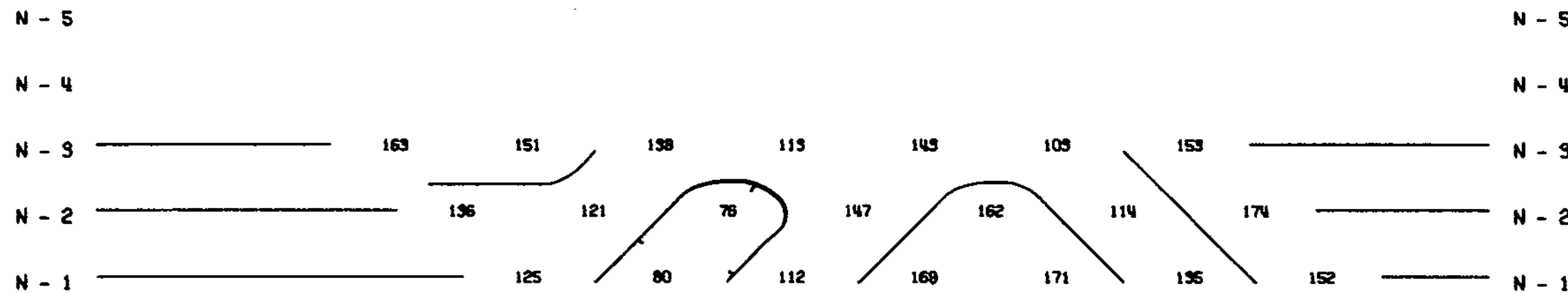

LINE NO. - 8000S

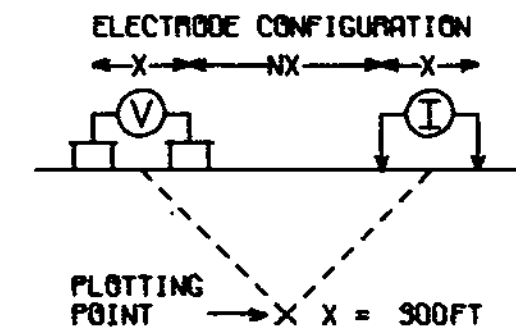

FREQUENCIES: 0.31-5.0 HZ

DATE SURVEYED: AUG 1972

NOTE: CONTOURS AT LOGARITHMIC INTERVALS 1.-1.5-2.-3.-5.-7.5-10

APPROVED: *[Signature]*
 BRITISH ENGINEER
 DATE: *Nov 6 1972*

McPHAR GEOPHYSICS

INDUCED POLARIZATION AND RESISTIVITY SURVEY

NOTE: THIS PLOT WAS PRODUCED BY McPHAR COMPUTER DIVISION

ISO EXPLORATIONS LTD.

KALCO VALLEY MINES LTD., (N.P.L.) OPTION,
SUMMERS CREEK VALLEY, TULAMEEN AREA,
SIMILKAMEEN M.D., BRITISH COLUMBIA.

LINE NO. - 7600S

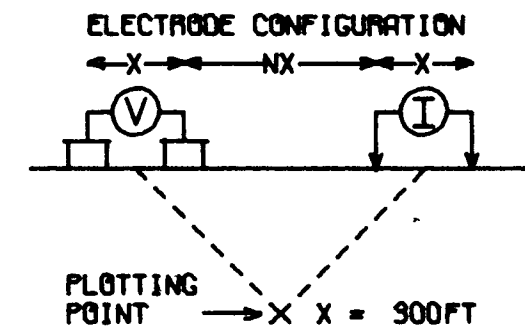

SURFACE PROJECTION
OF ANOMALOUS ZONES

DEFINITE
PROBABLE
POSSIBLE

FREQUENCIES: 0.91-5.0 HZ

DATE SURVEYED: AUG 1972

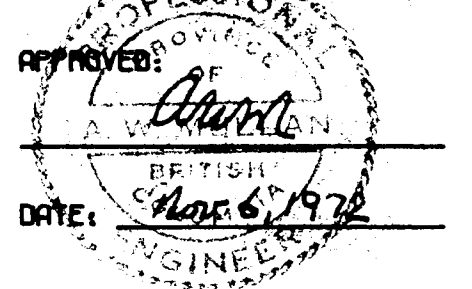

NOTE: CONTOURS AT
LOGARITHMIC INTERVALS
1.-1.5-2.-3.-5.-7.5-10

McPHAR GEOPHYSICS

INDUCED POLARIZATION AND RESISTIVITY SURVEY

NOTE: THIS PLOT WAS PRODUCED BY McPHAR COMPUTER DIVISION

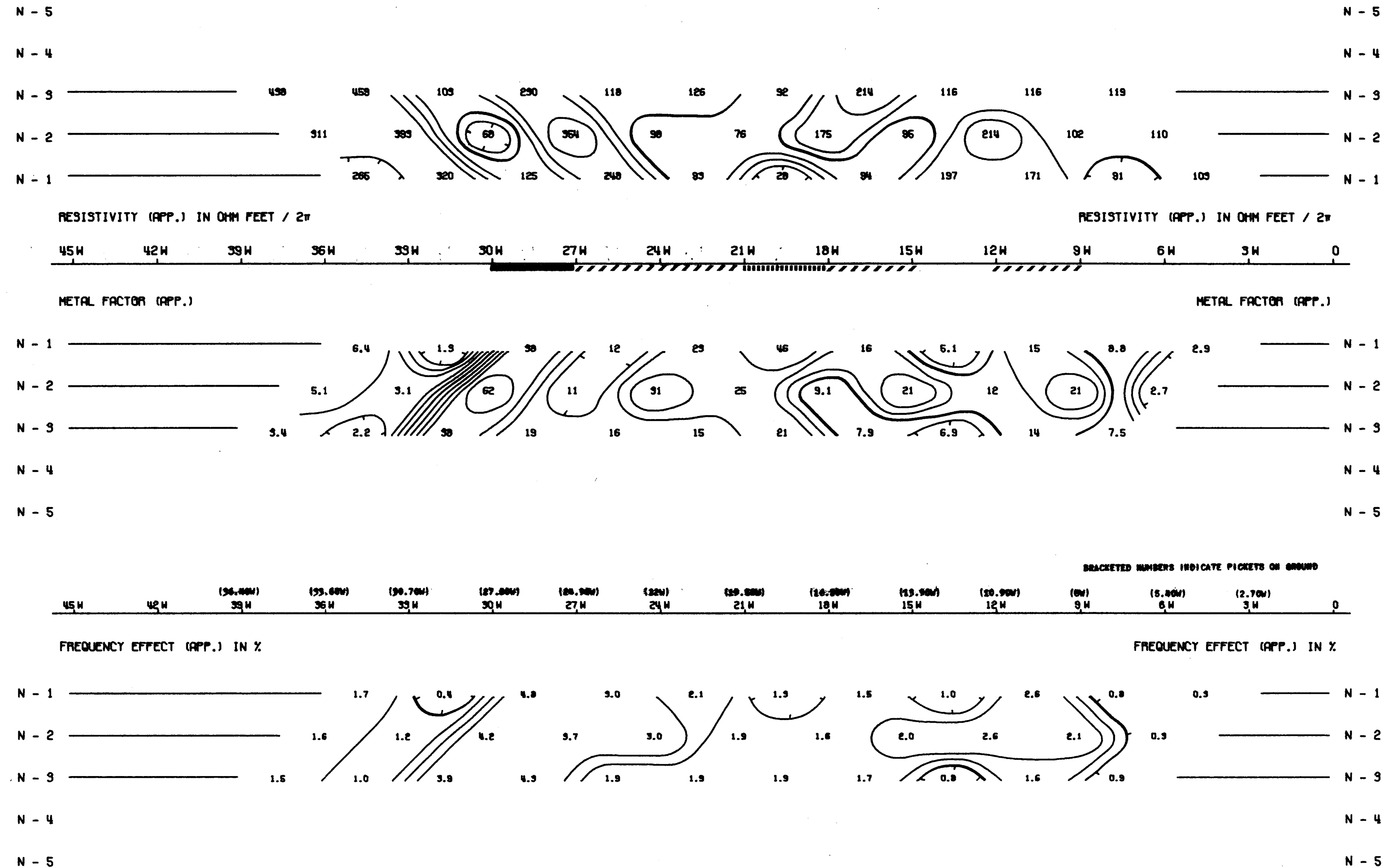

ISO EXPLORATIONS LTD.

KALCO VALLEY MINES LTD., (N.P.L.) OPTION,
SUMMERS CREEK VALLEY, TULAMEEN AREA,
SIMILKAMEEN M.D., BRITISH COLUMBIA.

LINE NO. - 7200S

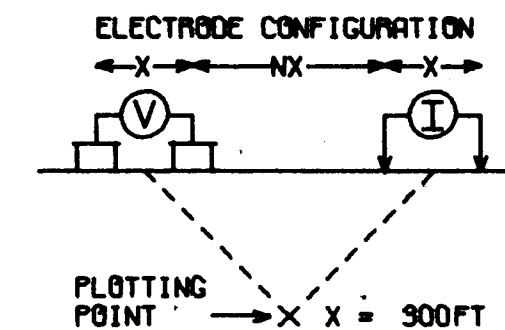

SURFACE PROJECTION
OF ANOMALOUS ZONES
DEFINITE
PROBABLE
POSSIBLE

FREQUENCIES: 0.31-5.0 HZ

DATE SURVEYED: AUG 1972

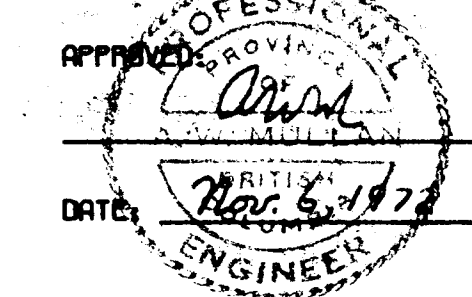

NOTE: CONTOURS AT
LOGARITHMIC INTERVALS
1.-1.5-2.-3.-5.-7.5-10

McPHAR GEOPHYSICS

INDUCED POLARIZATION AND RESISTIVITY SURVEY

NOTE: THIS PLOT WAS PRODUCED BY McPHAR COMPUTER DIVISION

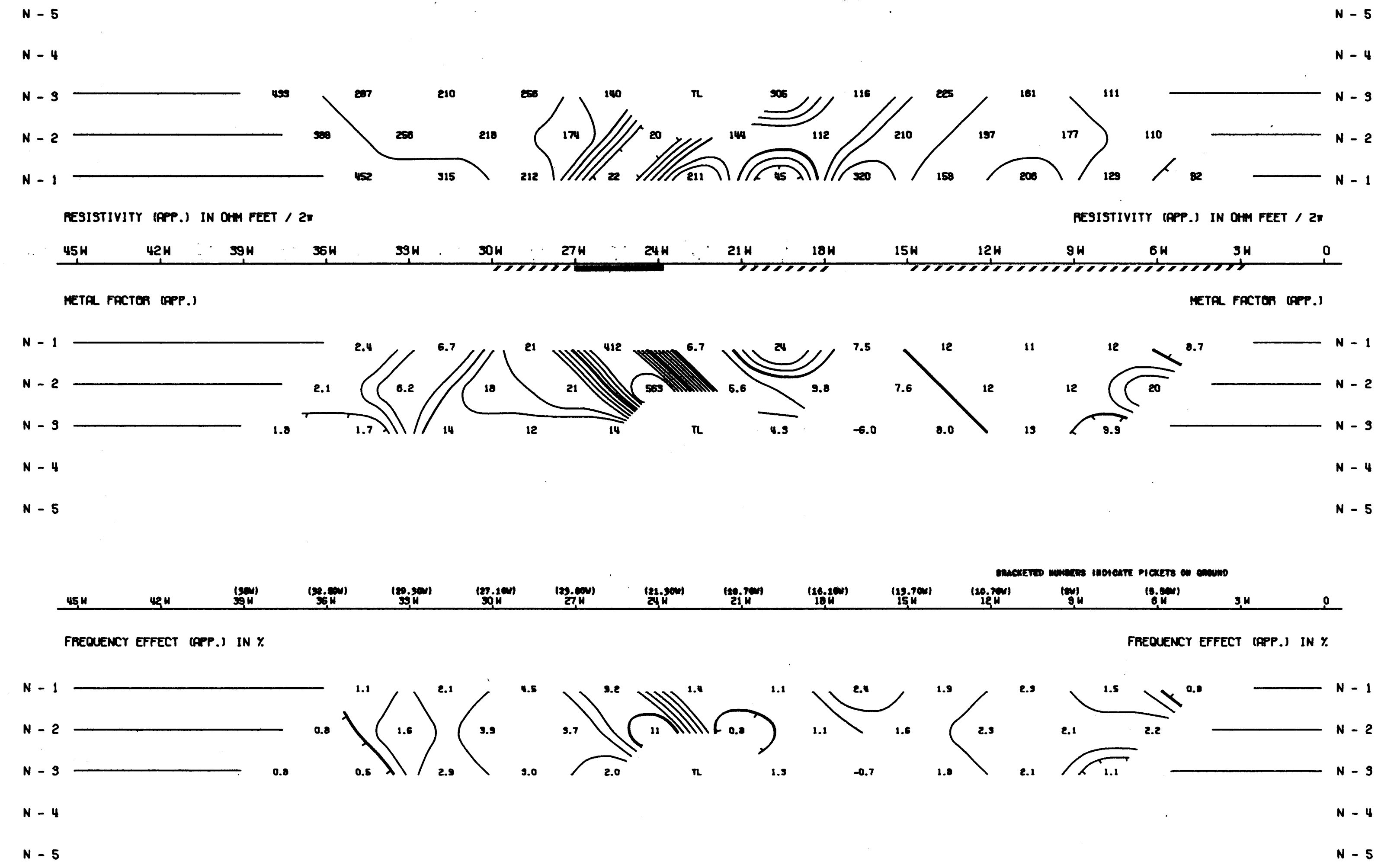

ISO EXPLORATIONS LTD.

KALCO VALLEY MINES LTD., (N.P.L.) OPTION,
SUMMERS CREEK VALLEY, TULAMEEN AREA,
SIMILKAMEEN M.D., BRITISH COLUMBIA.

LINE NO. - 6800S

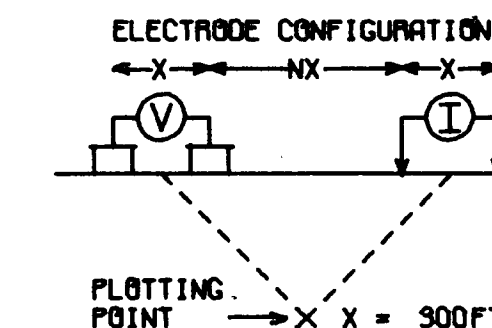

SURFACE PROJECTION
OF ANOMALOUS ZONES

DEFINITE **—————**
PROBABLE **|||||**
POSSIBLE **////**

FREQUENCIES: 0.31-5.0 HZ

DATE SURVEYED: AUG 1972

APPROVED: *[Signature]*

DATE: *Aug 6 1972*

ENGINEER

NOTE: CONTOURS AT
LOGARITHMIC INTERVALS
1.-1.5-2.-3.-5.-7.5-10

McPHAR GEOPHYSICS

INDUCED POLARIZATION AND RESISTIVITY SURVEY

NOTE: THIS PLOT WAS PRODUCED BY McPHAR COMPUTER DIVISION

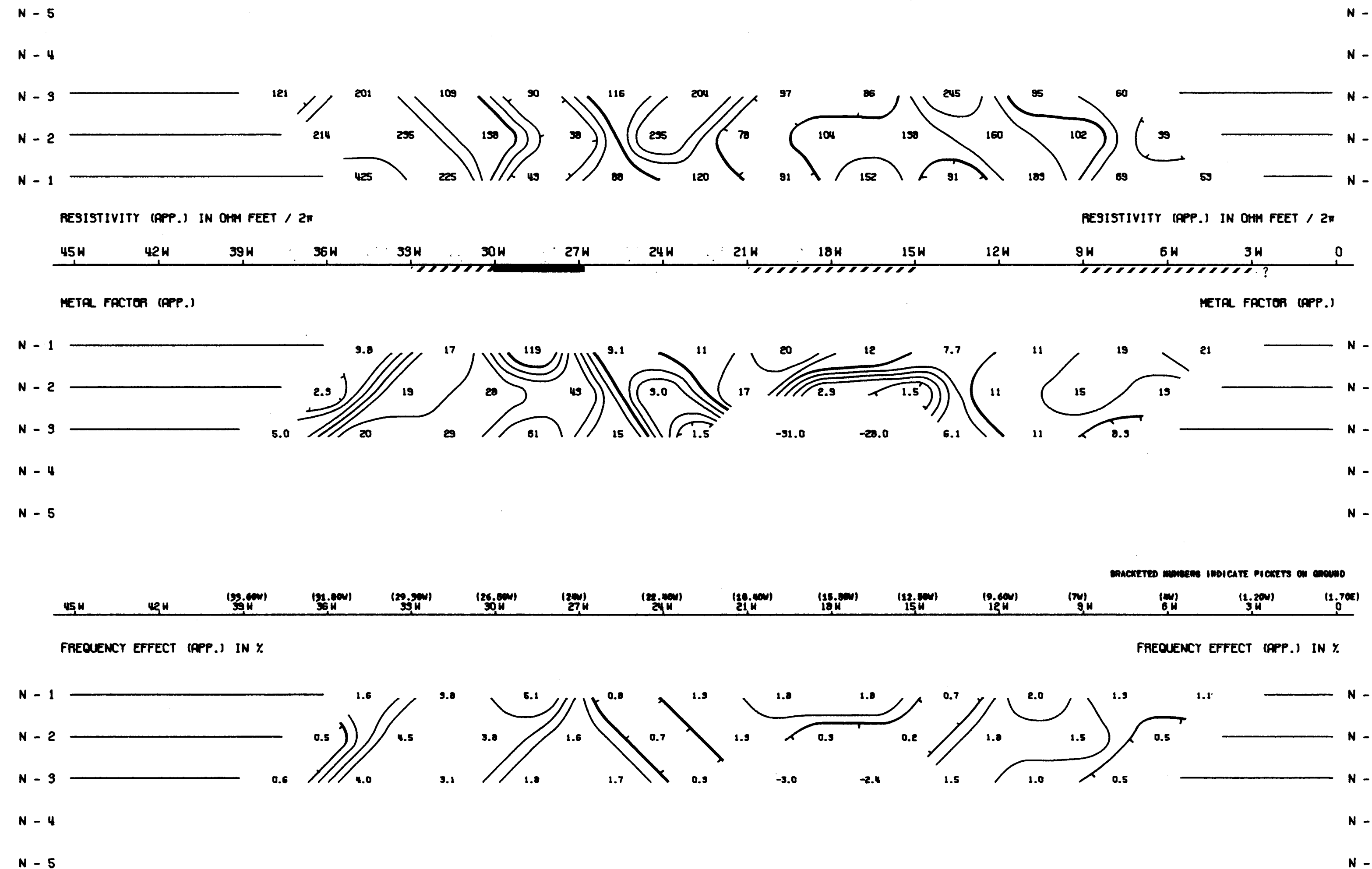

ISO EXPLORATIONS LTD.

KALCO VALLEY MINES LTD., (N.P.L.) OPTION,
SUMMERS CREEK VALLEY, TULAMEEN AREA,
SIMILKAMEEN M.D., BRITISH COLUMBIA.

LINE NO. - 6400S

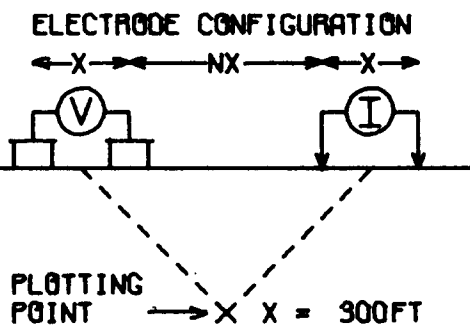

SURFACE PROJECTION
OF ANOMALOUS ZONES
DEFINITE —————
PROBABLE - - - - -
POSSIBLE / / / / /

FREQUENCIES: 0.91-5.0 HZ

DATE SURVEYED: AUG 1972

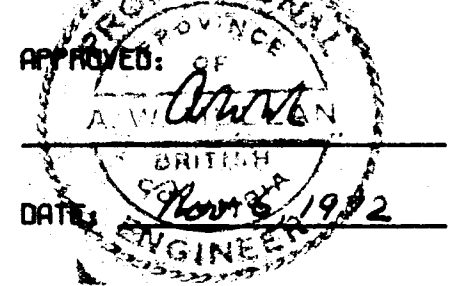

NOTE: CONTOURS AT
LOGARITHMIC INTERVALS
1.-1.5-2.-3.-5.-7.5-10

McPHAR GEOPHYSICS

INDUCED POLARIZATION AND RESISTIVITY SURVEY

NOTE: THIS PLOT WAS PRODUCED BY McPHAR COMPUTER DIVISION

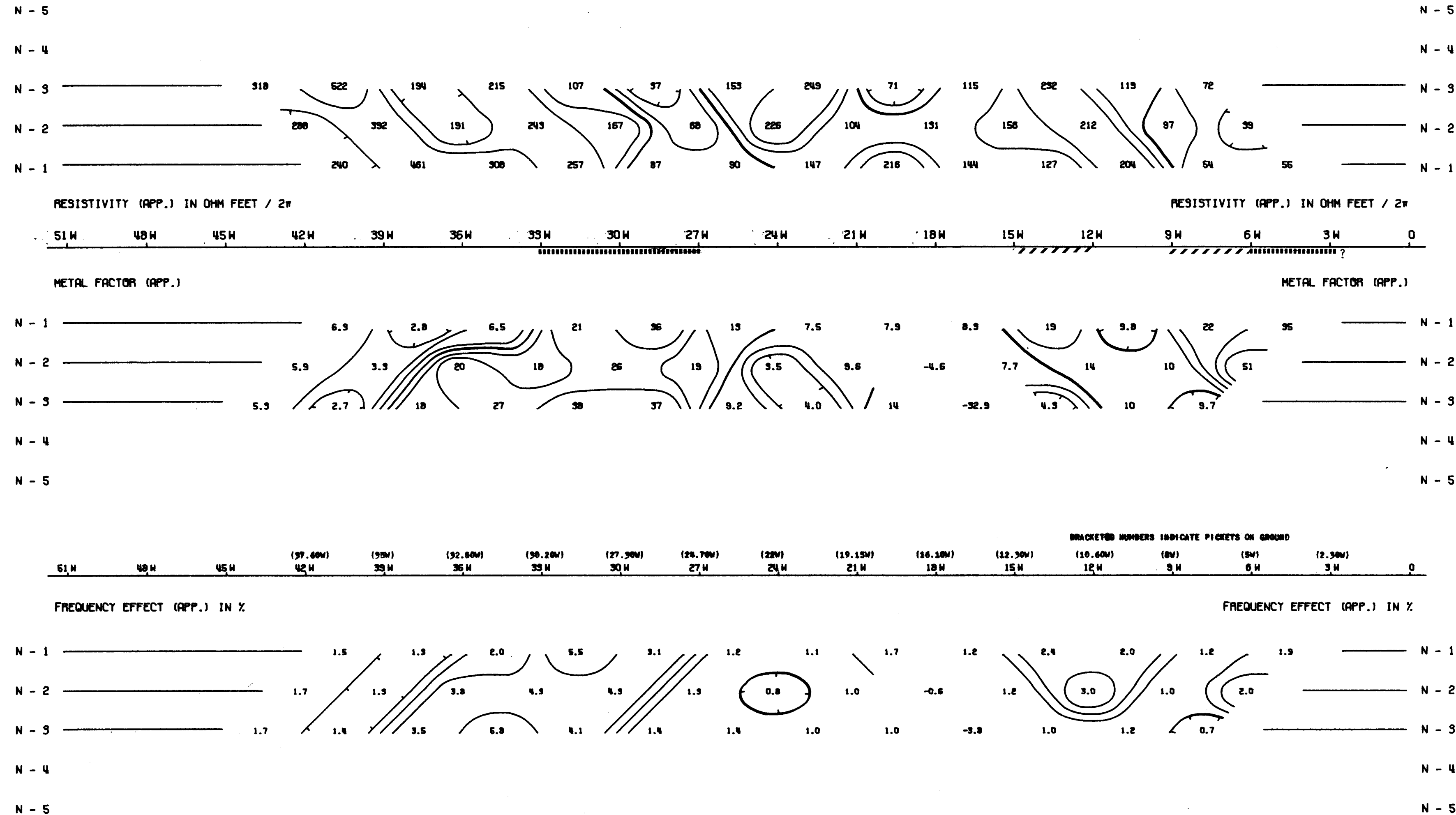

ISO EXPLORATIONS LTD.

KALCO VALLEY MINES LTD., (N.P.L.) OPTION,
SUMMERS CREEK VALLEY, TULAMEEN AREA,
SIMILKAMEEN M.D., BRITISH COLUMBIA.

LINE NO. - 6000S

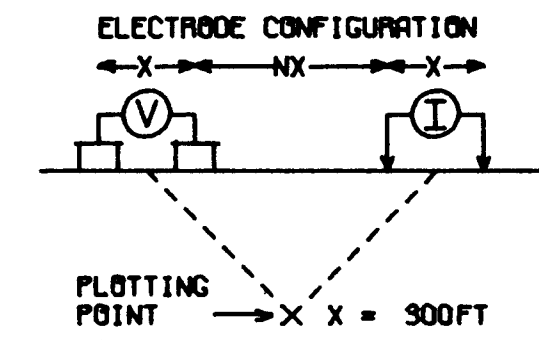

SURFACE PROJECTION
OF ANOMALOUS ZONES

DEFINITE **—————**

PROBABLE **|||||**

POSSIBLE **////**

FREQUENCIES: 0.31-5.0 HZ

DATE SURVEYED: AUG 1972

APPROVED: *[Signature]*

DATE: *[Signature]* 1972

PROFESSIONAL ENGINEER

NOTE: CONTOURS AT LOGARITHMIC INTERVALS 1.-1.5-2.-3.-5.-7.5-10

McPHAR GEOPHYSICS

INDUCED POLARIZATION AND RESISTIVITY SURVEY

NOTE: THIS PLOT WAS PRODUCED BY McPHAR COMPUTER DIVISION

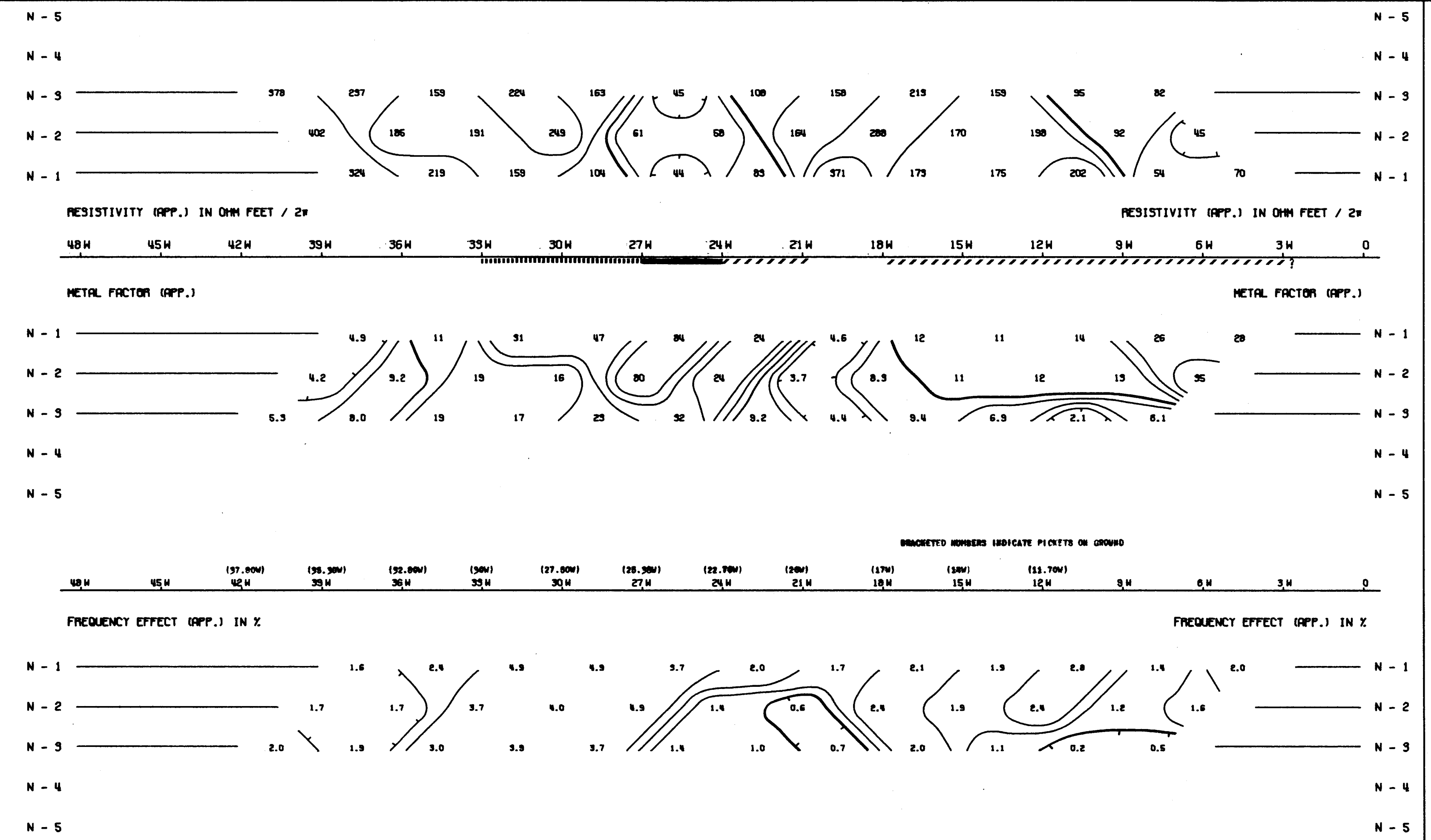

ISO EXPLORATIONS LTD.

KALCO VALLEY MINES LTD., (N.P.L.) OPTION,
SUMMERS CREEK VALLEY, TULAMEEN AREA,
SIMILKAMEEN M.D., BRITISH COLUMBIA.

LINE NO. - 5600S

ELECTRODE CONFIGURATION

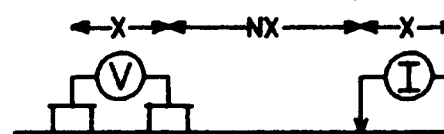

PLOTTING POINT X X = 300FT

SURFACE PROJECTION OF ANOMALOUS ZONES

DEFINITE **————**
PROBABLE **|||||**
POSSIBLE **////**

FREQUENCIES: 0.31-5.0 HZ

DATE SURVEYED: AUG 1972

APPROVED: *[Signature]*
DATE: *Nov. 6, 1972*

NOTE: CONTOURS AT LOGARITHMIC INTERVALS 1.-1.5-2.-3.-5.-7.5-10

McPHAR GEOPHYSICS

INDUCED POLARIZATION AND RESISTIVITY SURVEY

NOTE: THIS PLOT WAS PRODUCED BY McPHAR COMPUTER DIVISION

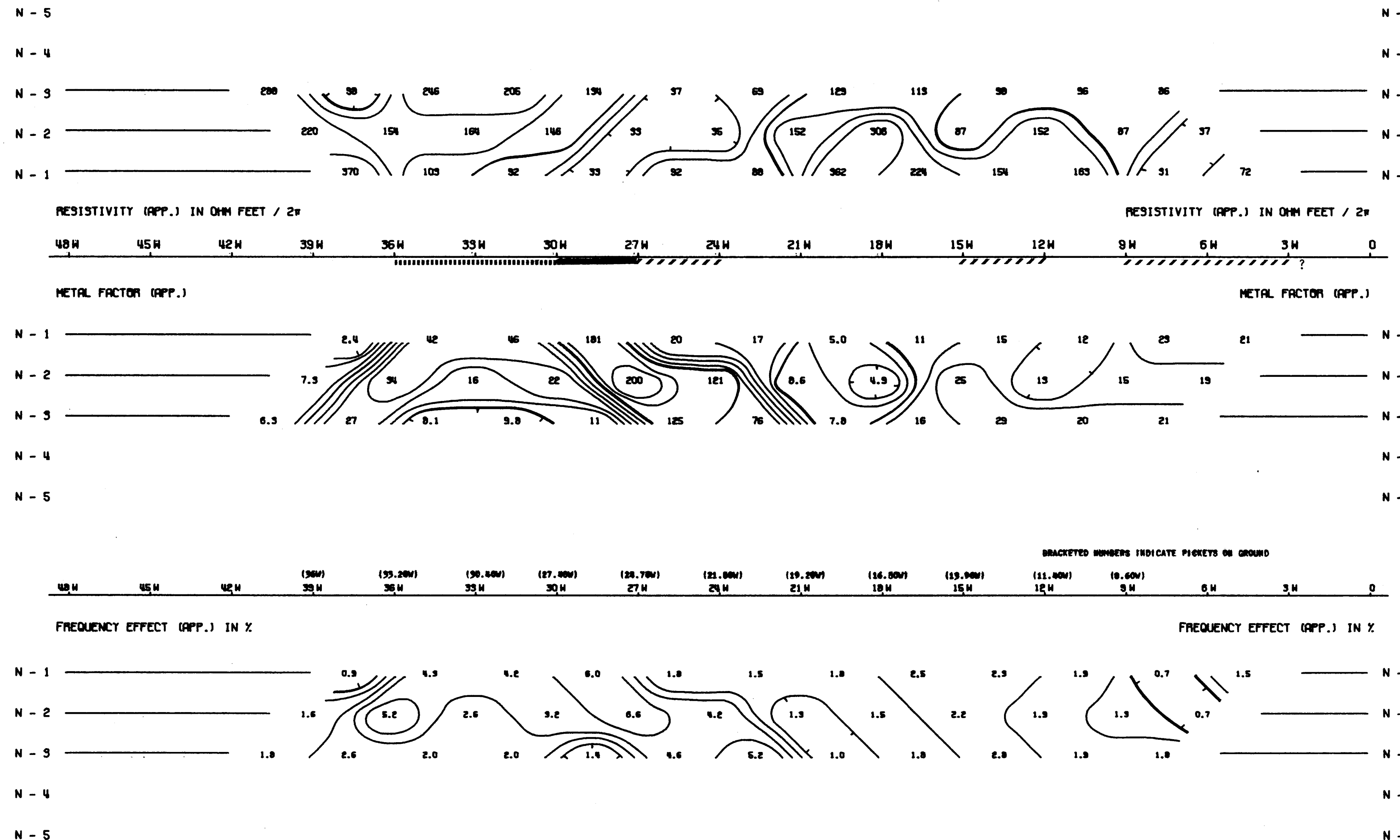

ISO EXPLORATIONS LTD.

KALCO VALLEY MINES LTD., (N.P.L.) OPTION,
SUMMERS CREEK VALLEY, TULAMEEN AREA,
SIMILKAMEEN M.O., BRITISH COLUMBIA.

LINE NO. - 5200S

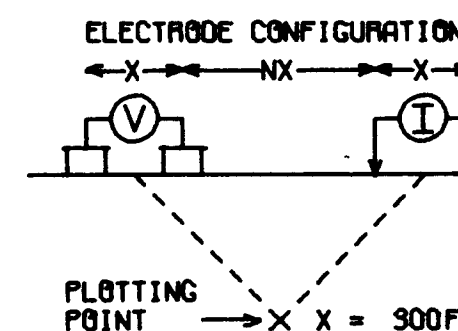

SURFACE PROJECTION
OF ANOMALOUS ZONES
DEFINITE
PROBABLE
POSSIBLE

FREQUENCIES: 0.31-5.0 HZ

DATE SURVEYED: AUG 1972

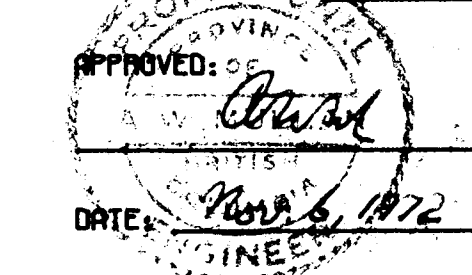

NOTE: CONTOURS AT
LOGARITHMIC INTERVALS
1.-1.5-2.-3.-5.-7.5-10

McPHAR GEOPHYSICS

INDUCED POLARIZATION AND RESISTIVITY SURVEY

NOTE: THIS PLOT WAS PRODUCED BY McPHAR COMPUTER DIVISION

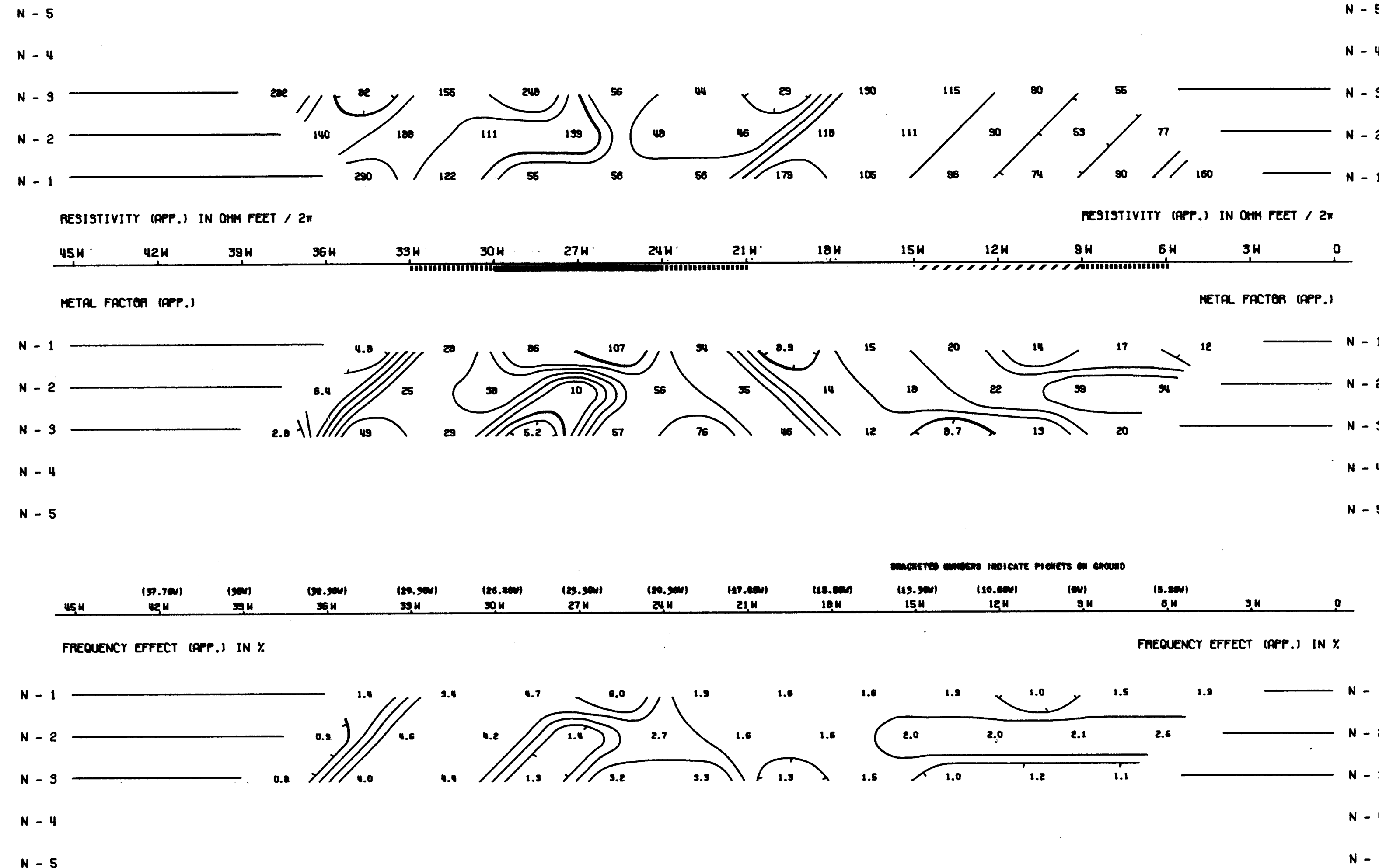

ISO EXPLORATIONS LTD.

KALCO VALLEY MINES LTD., (N.P.L.) OPTION,
SUMMERS CREEK VALLEY, TULAMEEN AREA,
SIMILKAMEEN M.D., BRITISH COLUMBIA.

LINE NO. - 4800S

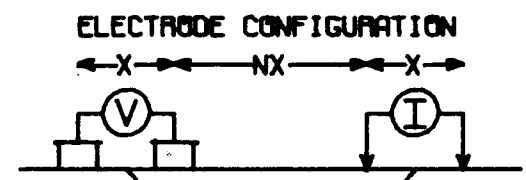

PLOTTING POINT → X X = 300FT

SURFACE PROJECTION OF ANOMALOUS ZONES

DEFINITE **————**
PROBABLE **.....**
POSSIBLE **////**

FREQUENCIES: 0.31-5.0 HZ

DATE SURVEYED: AUG 1972

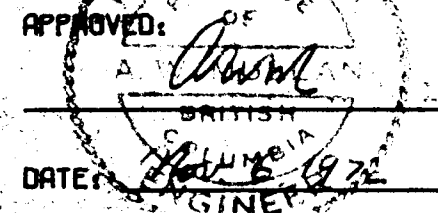

NOTE: CONTOURS AT LOGARITHMIC INTERVALS 1.-1.5-2.-3.-5.-7.5-10

McPHAR GEOPHYSICS

INDUCED POLARIZATION AND RESISTIVITY SURVEY

NOTE: THIS PLOT WAS PRODUCED BY McPHAR COMPUTER DIVISION

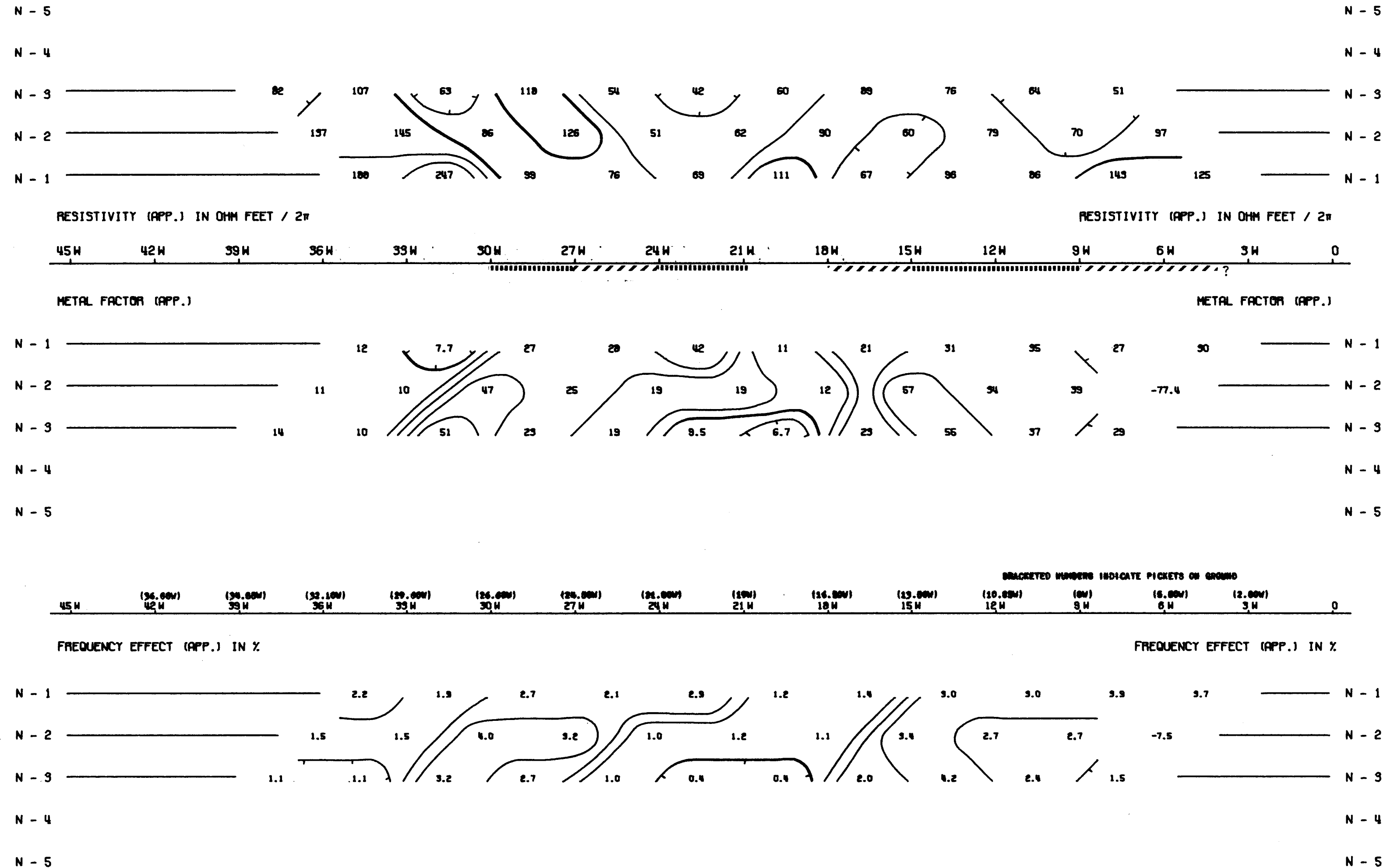

ISO EXPLORATIONS LTD.

KALCO VALLEY MINES LTD., (N.P.L.) OPTION,
SUMMERS CREEK VALLEY, TULAMEEN AREA,
SIMILKAMEEN M.D., BRITISH COLUMBIA.

LINE NO. - 4400S

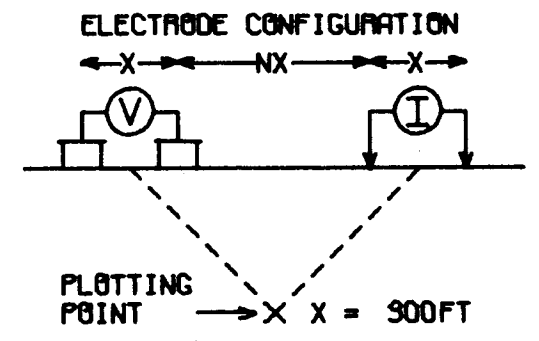

SURFACE PROJECTION
OF ANOMALOUS ZONES
DEFINITE
PROBABLE
POSSIBLE

FREQUENCIES: 0.31-5.0 HZ

DATE SURVEYED: AUG 1972

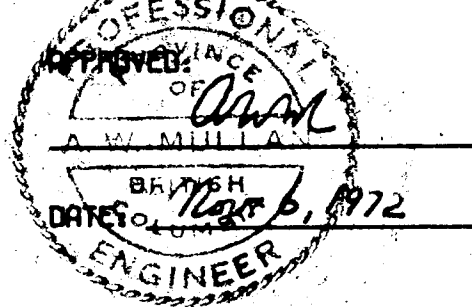

NOTE: CONTOURS AT
LOGARITHMIC INTERVALS
1.-1.5-2.-3.-5.-7.5-10

McPHAR GEOPHYSICS

INDUCED POLARIZATION AND RESISTIVITY SURVEY

NOTE: THIS PLOT WAS PRODUCED BY McPHAR COMPUTER DIVISION

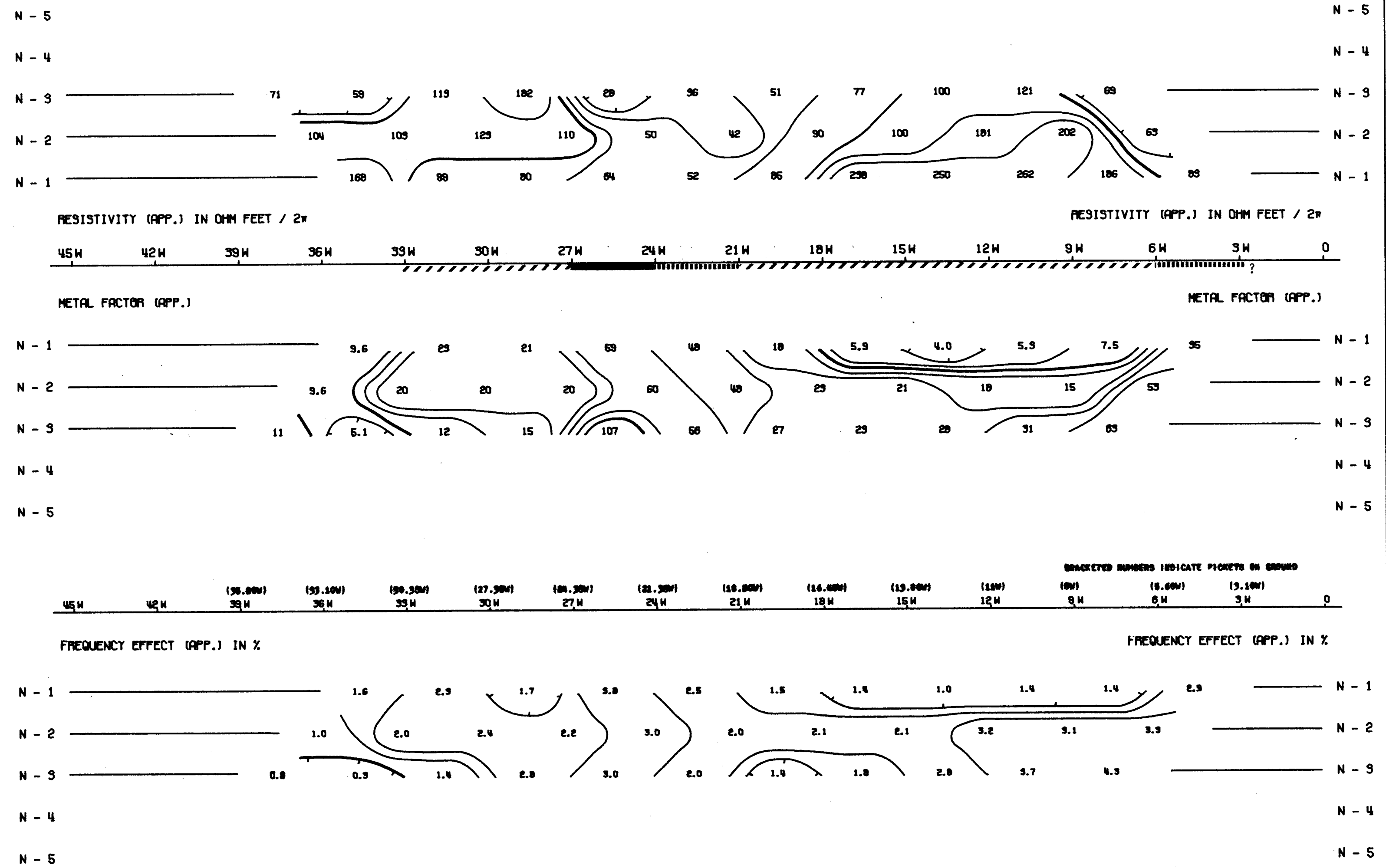

ISO EXPLORATIONS LTD.

KALCO VALLEY MINES LTD., (N.P.L.) OPTION,
SUMMERS CREEK VALLEY, TULAMEEN AREA,
SIMILKAMEEN M.D., BRITISH COLUMBIA.

LINE NO. - 4000S

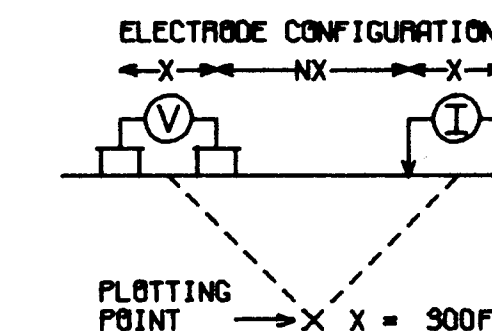

SURFACE PROJECTION
OF ANOMALOUS ZONES

DEFINITE **————**
PROBABLE **|||||**
POSSIBLE **////**

FREQUENCIES: 0.91-5.0 HZ

DATE SURVEYED: AUG 1972

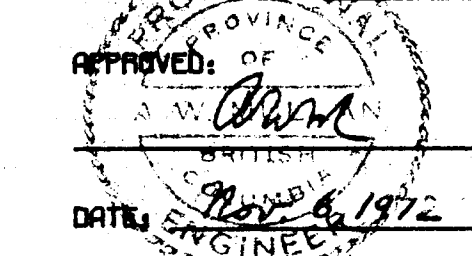

NOTE: CONTOURS AT
LOGARITHMIC INTERVALS
1.-1.5-2.-3.-5.-7.5-10

McPHAR GEOPHYSICS

INDUCED POLARIZATION AND RESISTIVITY SURVEY

NOTE: THIS PLOT WAS PRODUCED BY McPHAR COMPUTER DIVISION

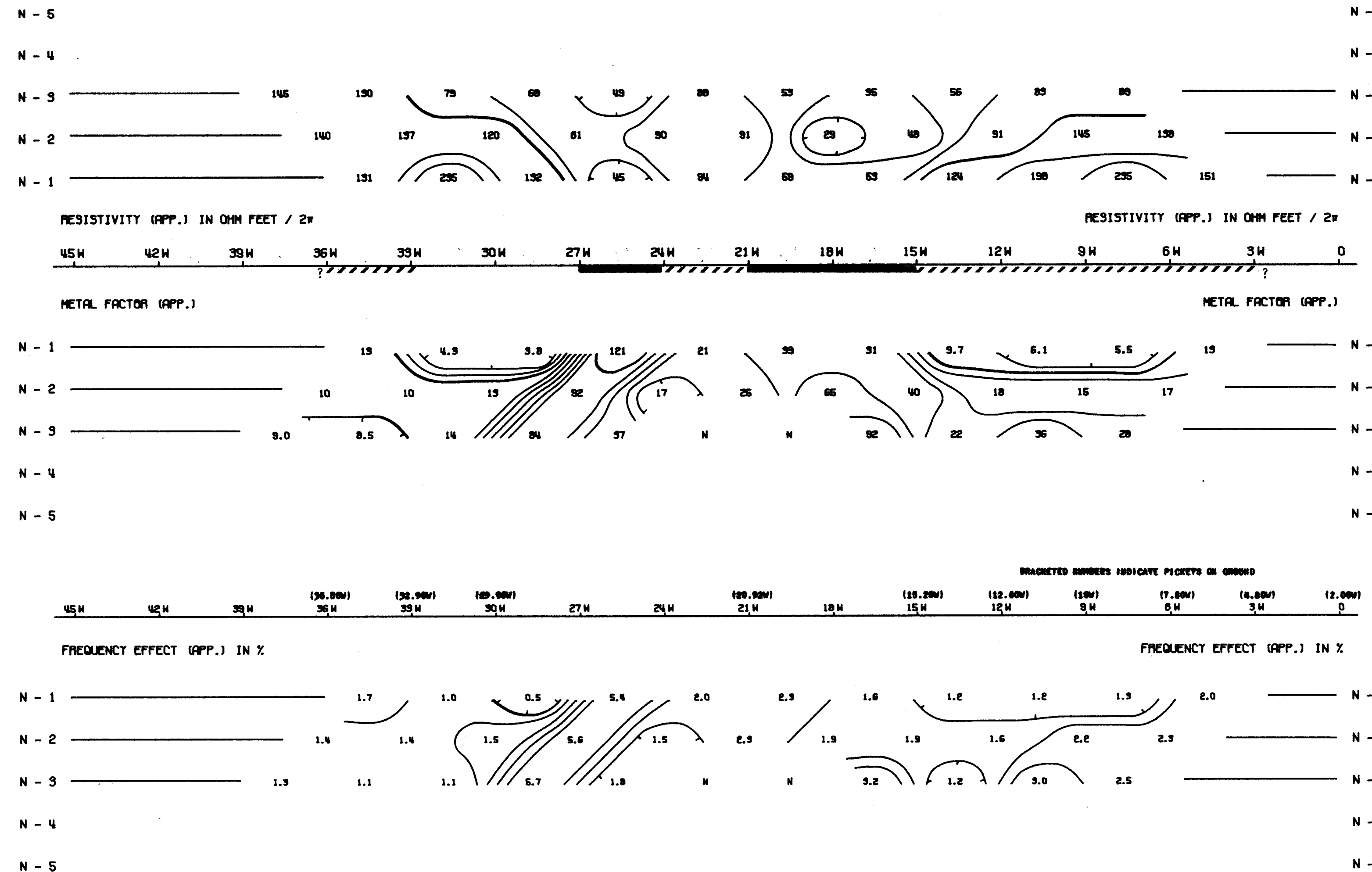

ISO EXPLORATIONS LTD.

KALCO VALLEY MINES LTD., (N.P.L.) OPTION,
SUMMERS CREEK VALLEY, TULAMEEN AREA,
SIMILKAMEEN M.D., BRITISH COLUMBIA.

LINE NO. - 3600S

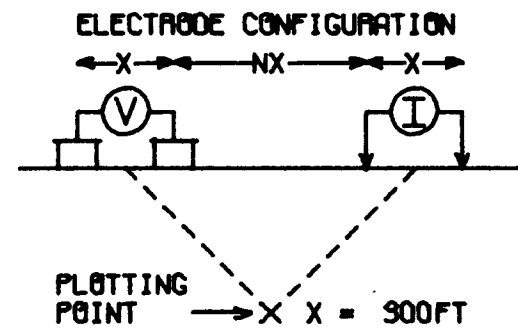

SURFACE PROJECTION
OF ANOMALOUS ZONES

DEFINITE
PROBABLE
POSSIBLE

FREQUENCIES: 0.31-5.0 HZ

DATE SURVEYED: AUG 1972

APPROVED:

NOTE: CONTOURS AT
LOGARITHMIC INTERVALS
1.-1.5-2.-3.-5.-7.5-10

DATE: 1972

McPHAR GEOPHYSICS

INDUCED POLARIZATION AND RESISTIVITY SURVEY

NOTE: THIS PLOT WAS PRODUCED BY McPHAR COMPUTER DIVISION

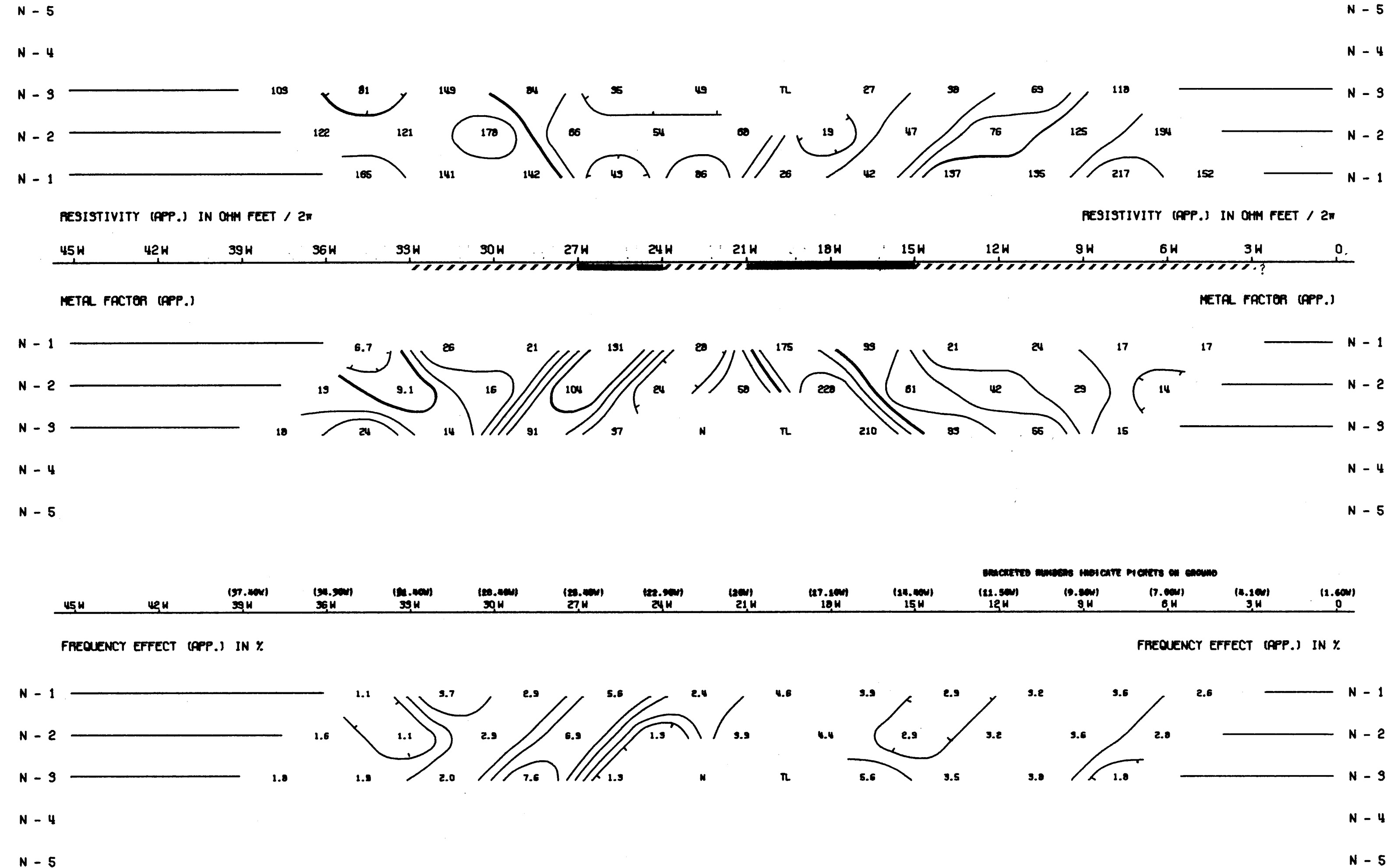

ISO EXPLORATIONS LTD.

KALCO VALLEY MINES LTD., (N.P.L.) OPTION,
SUMMERS CREEK VALLEY, TULAMEEN AREA,
SIMILKAMEEN M.D., BRITISH COLUMBIA.

LINE NO. - 3200S

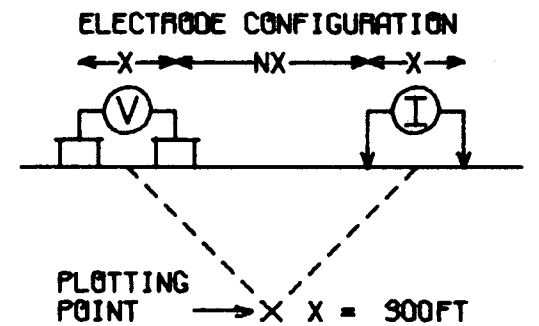

SURFACE PROJECTION
OF ANOMALOUS ZONES
DEFINITE **—————**
PROBABLE **|||||**
POSSIBLE **////**

FREQUENCIES: 0.31-5.0 HZ

DATE SURVEYED: AUG 1972

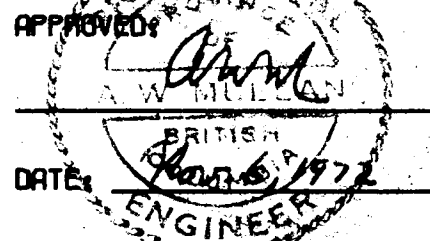

NOTE: CONTOURS AT
LOGARITHMIC INTERVALS
1.-1.5-2.-3.-5.-7.5-10

McPHAR GEOPHYSICS

INDUCED POLARIZATION AND RESISTIVITY SURVEY

NOTE: THIS PLOT WAS PRODUCED BY McPHAR COMPUTER DIVISION

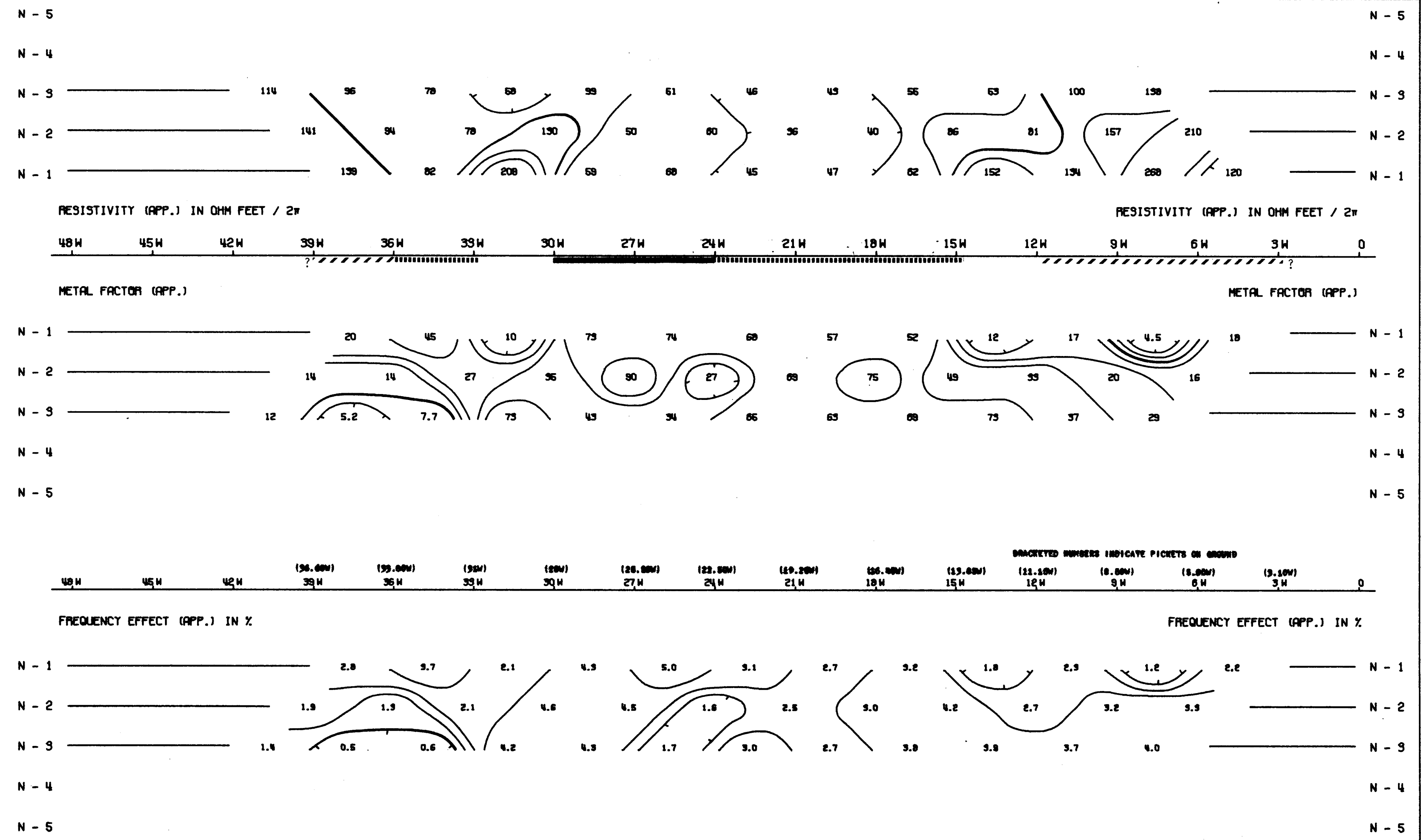

ISO EXPLORATIONS LTD.

KALCO VALLEY MINES LTD., (N.P.L.) OPTION,
SUMMERS CREEK VALLEY, TULAMEEN AREA,
SIMILKAMEEN M.D., BRITISH COLUMBIA.

LINE NO. - 2800S

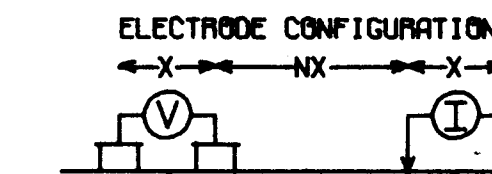

PLOTTING POINT → X X = 300FT

SURFACE PROJECTION OF ANOMALOUS ZONES

DEFINITE
PROBABLE
POSSIBLE

FREQUENCIES: 0.31-5.0 HZ

DATE SURVEYED: AUG 1972

APPROVED:

NOTE: CONTOURS AT LOGARITHMIC INTERVALS 1.-1.5-2.-3.-5.-7.5-10

DATE: 1972
ENGINEER

McPHAR GEOPHYSICS

INDUCED POLARIZATION AND RESISTIVITY SURVEY

NOTE: THIS PLOT WAS PRODUCED BY McPHAR COMPUTER DIVISION

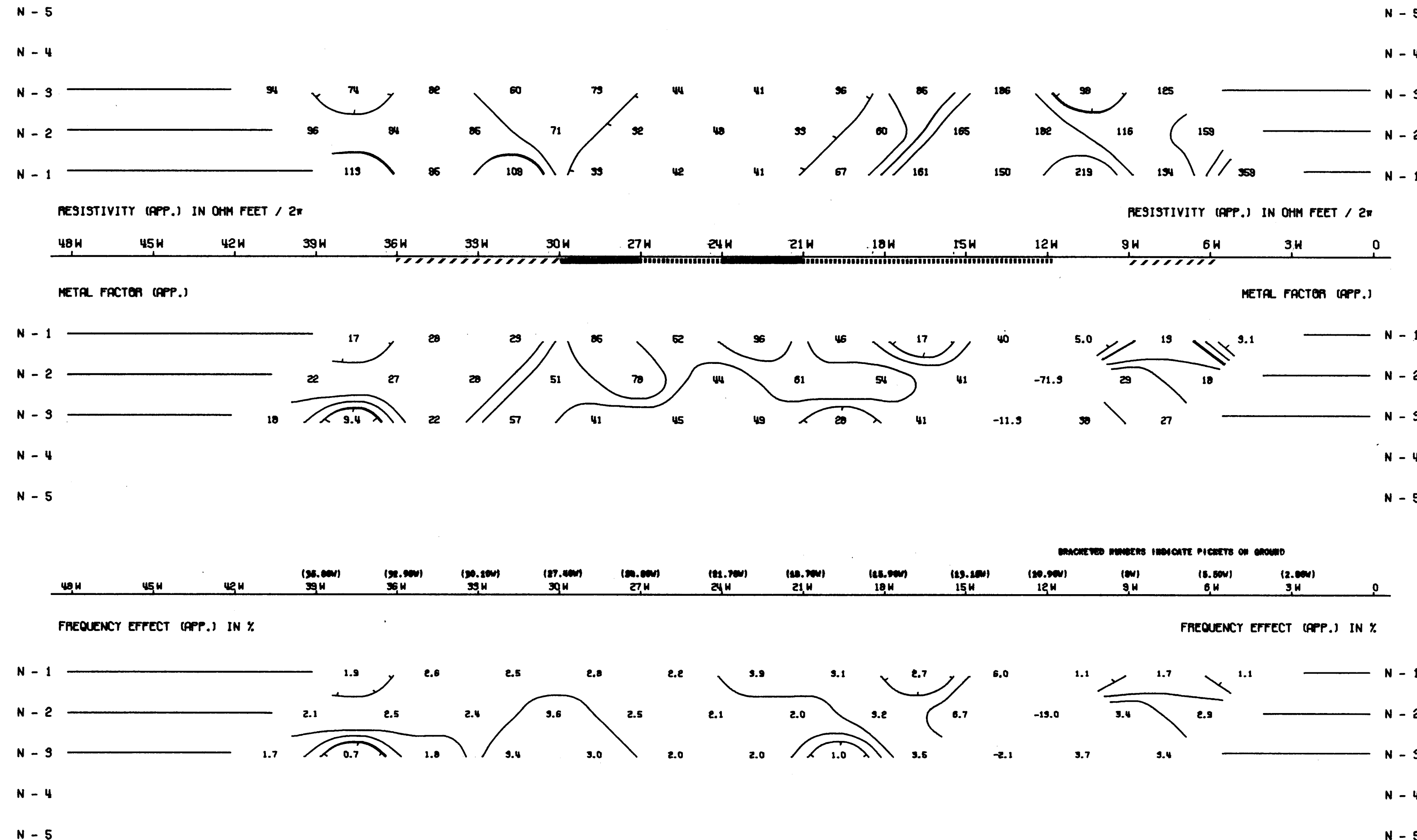

ISO EXPLORATIONS LTD.

KALCO VALLEY MINES LTD., (N.P.L.) OPTION,
SUMMERS CREEK VALLEY, TULAMEEN AREA,
SIMILKAMEEN M.D., BRITISH COLUMBIA.

LINE NO. - 2400S

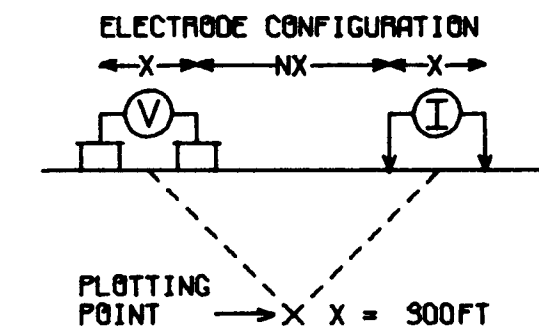

SURFACE PROJECTION
OF ANOMALOUS ZONES
DEFINITE
PROBABLE
POSSIBLE

FREQUENCIES: 0.91-5.0 HZ

DATE SURVEYED: AUG 1972

APPROVED:

DATE: 5/18/72
ENGINEER

NOTE: CONTOURS AT
LOGARITHMIC INTERVALS
1.-1.5-2.-3.-5.-7.5-10

McPHAR GEOPHYSICS

INDUCED POLARIZATION AND RESISTIVITY SURVEY

NOTE: THIS PLOT WAS PRODUCED BY McPHAR COMPUTER DIVISION

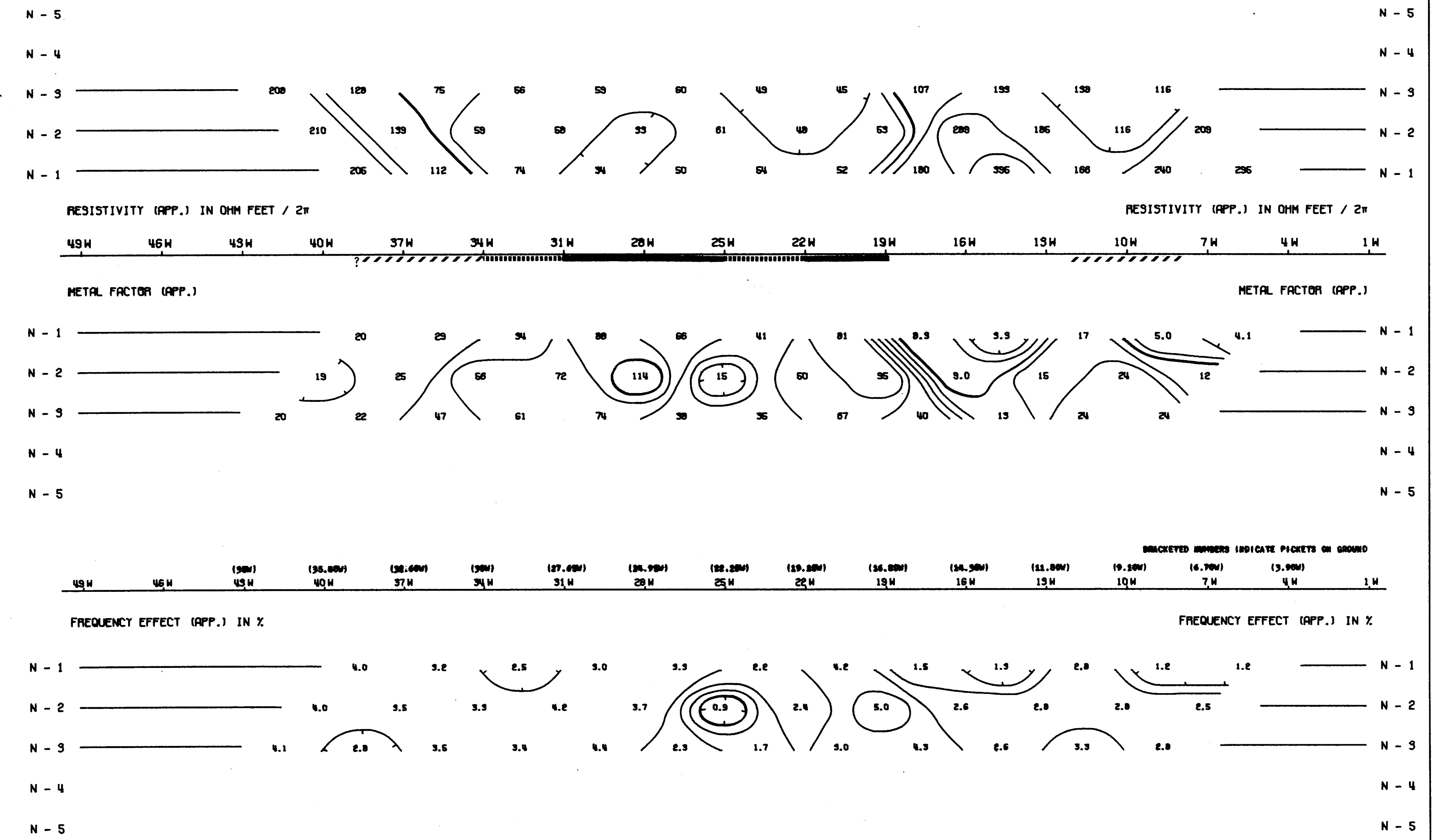

ISO EXPLORATIONS LTD.

KALCO VALLEY MINES LTD., (N.P.L.) OPTION,
SUMMERS CREEK VALLEY, TULAMEEN AREA,
SIMILKAMEEN M.D., BRITISH COLUMBIA.

LINE NO. - 2000S

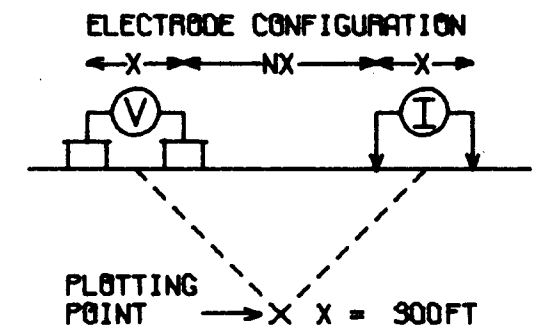

SURFACE PROJECTION
OF ANOMALOUS ZONES
DEFINITE **—————**
PROBABLE **|||||**
POSSIBLE **////**

FREQUENCIES: 0.31-5.0 HZ

DATE SURVEYED: AUG 1972

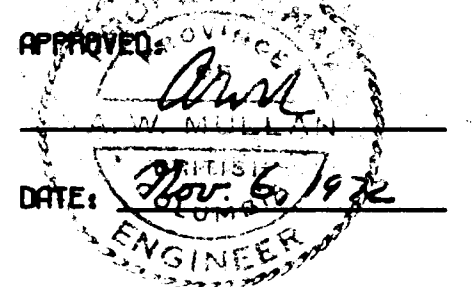

NOTE: CONTOURS AT
LOGARITHMIC INTERVALS
1.-1.5-2.-3.-5.-7.5-10

McPHAR GEOPHYSICS

INDUCED POLARIZATION AND RESISTIVITY SURVEY

NOTE: THIS PLOT WAS PRODUCED BY McPHAR COMPUTER DIVISION

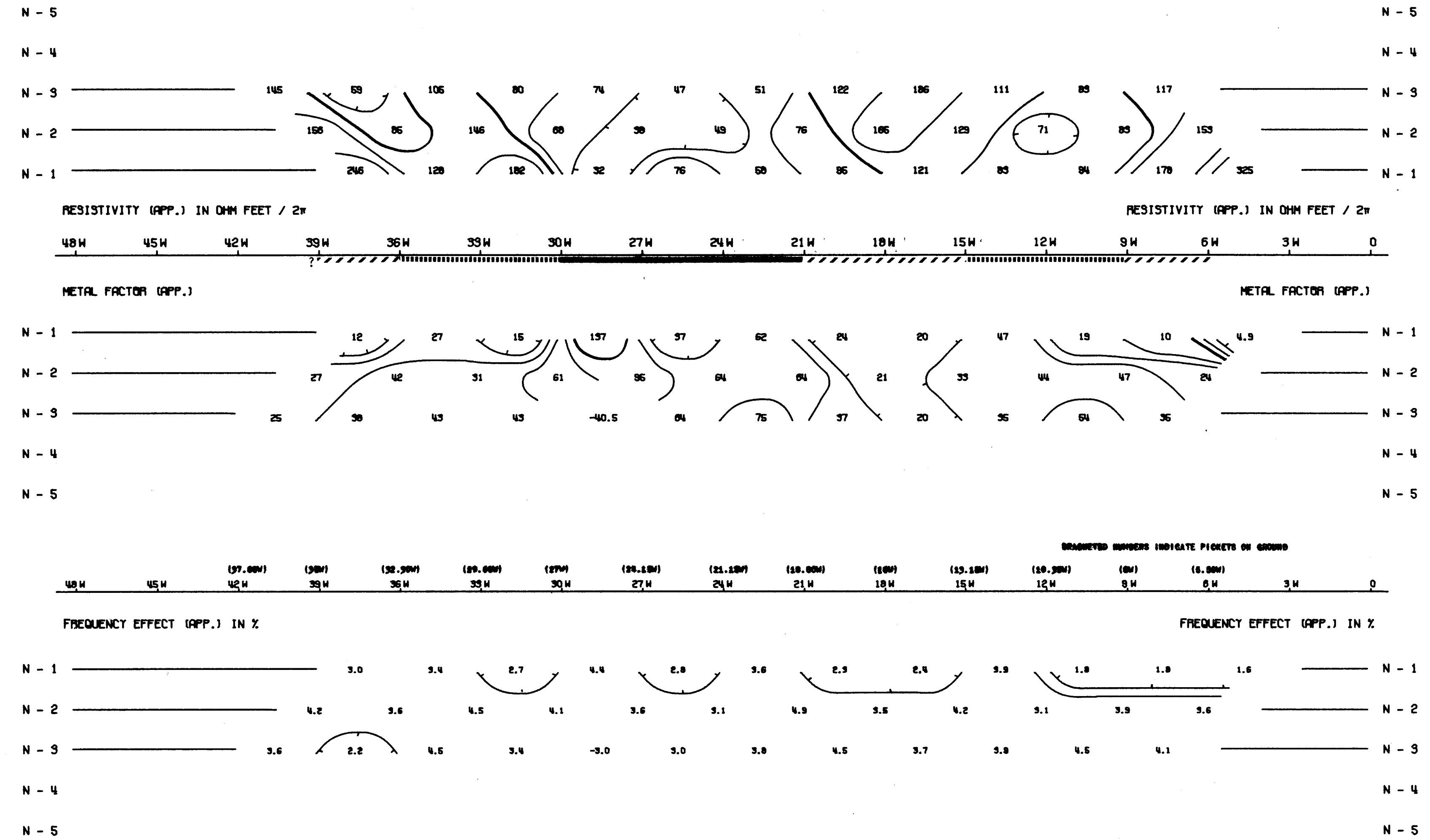

ISO EXPLORATIONS LTD.

KALCO VALLEY MINES LTD., (N.P.L.) OPTION,
SUMMERS CREEK VALLEY, TULAMEEN AREA,
SIMILKAMEEN M.D., BRITISH COLUMBIA.

LINE NO. - 1600S

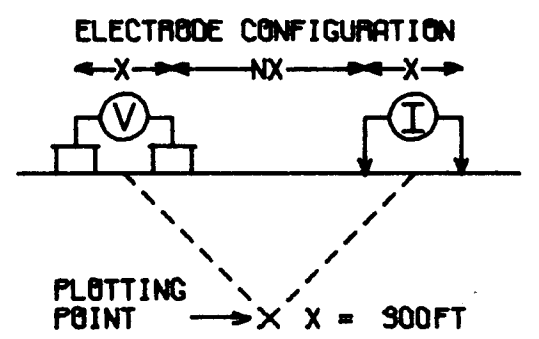

SURFACE PROJECTION
OF ANOMALOUS ZONES
DEFINITE —————
PROBABLE |||
POSSIBLE / / / /

FREQUENCIES: 0.91-5.0 HZ

DATE SURVEYED: AUG 1972



NOTE: CONTOURS AT
LOGARITHMIC INTERVALS
1.-1.5-2.-3.-5.-7.5-10

McPHAR GEOPHYSICS

INDUCED POLARIZATION AND RESISTIVITY SURVEY

NOTE: THIS PLOT WAS PRODUCED BY McPHAR COMPUTER DIVISION

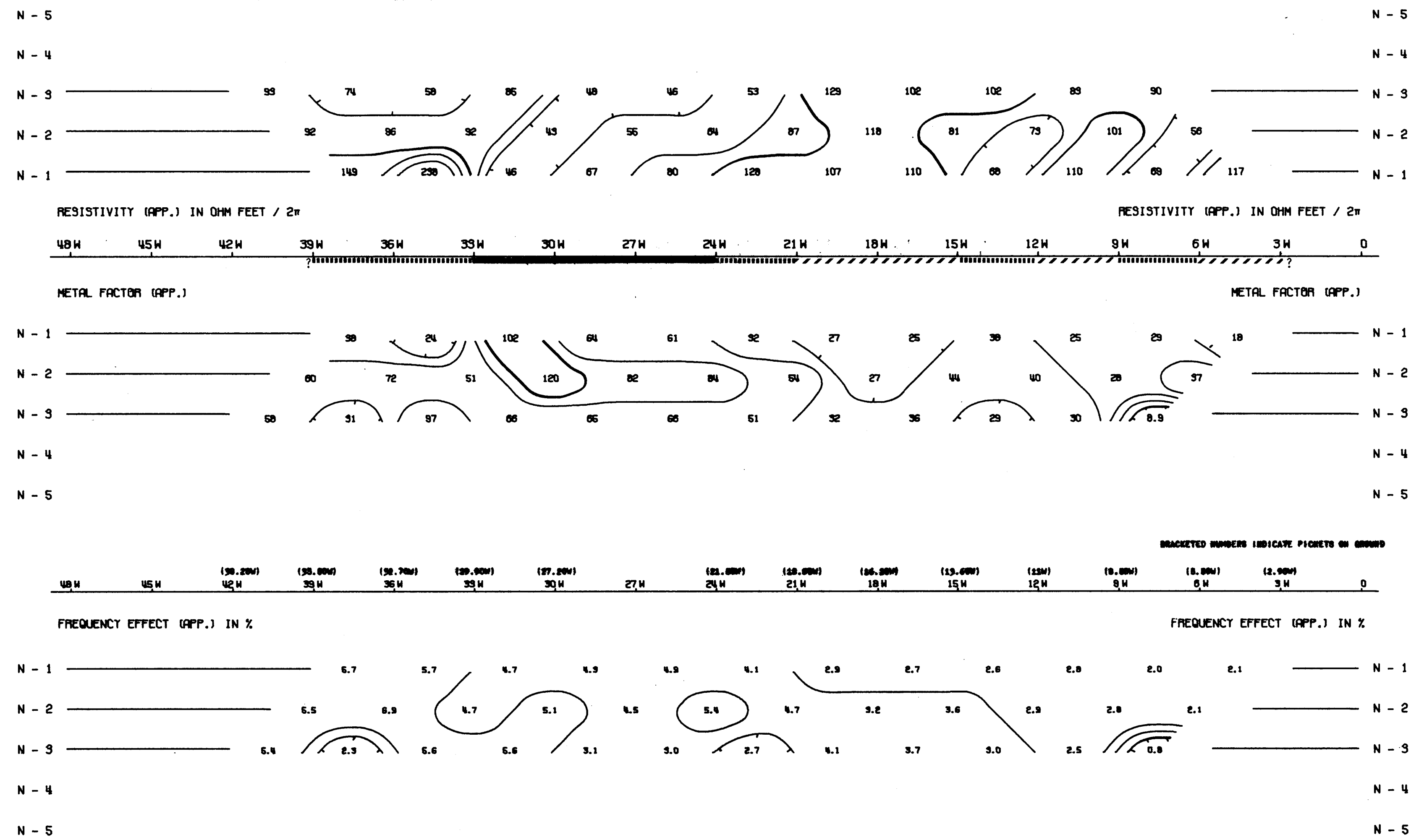

ISO EXPLORATIONS LTD.

KALCO VALLEY MINES LTD., (N.P.L.) OPTION,
SUMMERS CREEK VALLEY, TULAMEEN AREA,
SIMILKAMEEN M.D., BRITISH COLUMBIA.

LINE NO. - 1200S

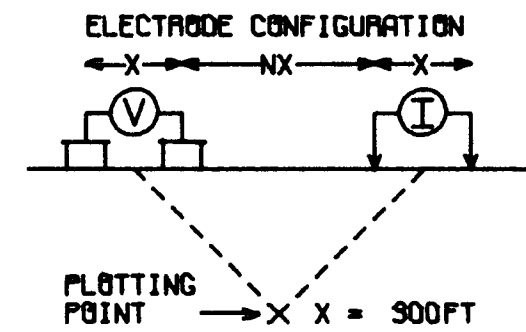

SURFACE PROJECTION OF ANOMALOUS ZONES

DEFINITE **————**

PROBABLE **|||||**

POSSIBLE **////**

FREQUENCIES: 0.31-5.0 HZ

DATE SURVEYED: 12 AUG 1972

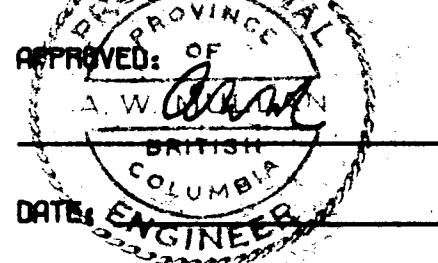

NOTE: CONTOURS AT LOGARITHMIC INTERVALS 1.-1.5-2.-3.-5.-7.5-10

McPHAR GEOPHYSICS

INDUCED POLARIZATION AND RESISTIVITY SURVEY

NOTE: THIS PLOT WAS PRODUCED BY McPHAR COMPUTER DIVISION

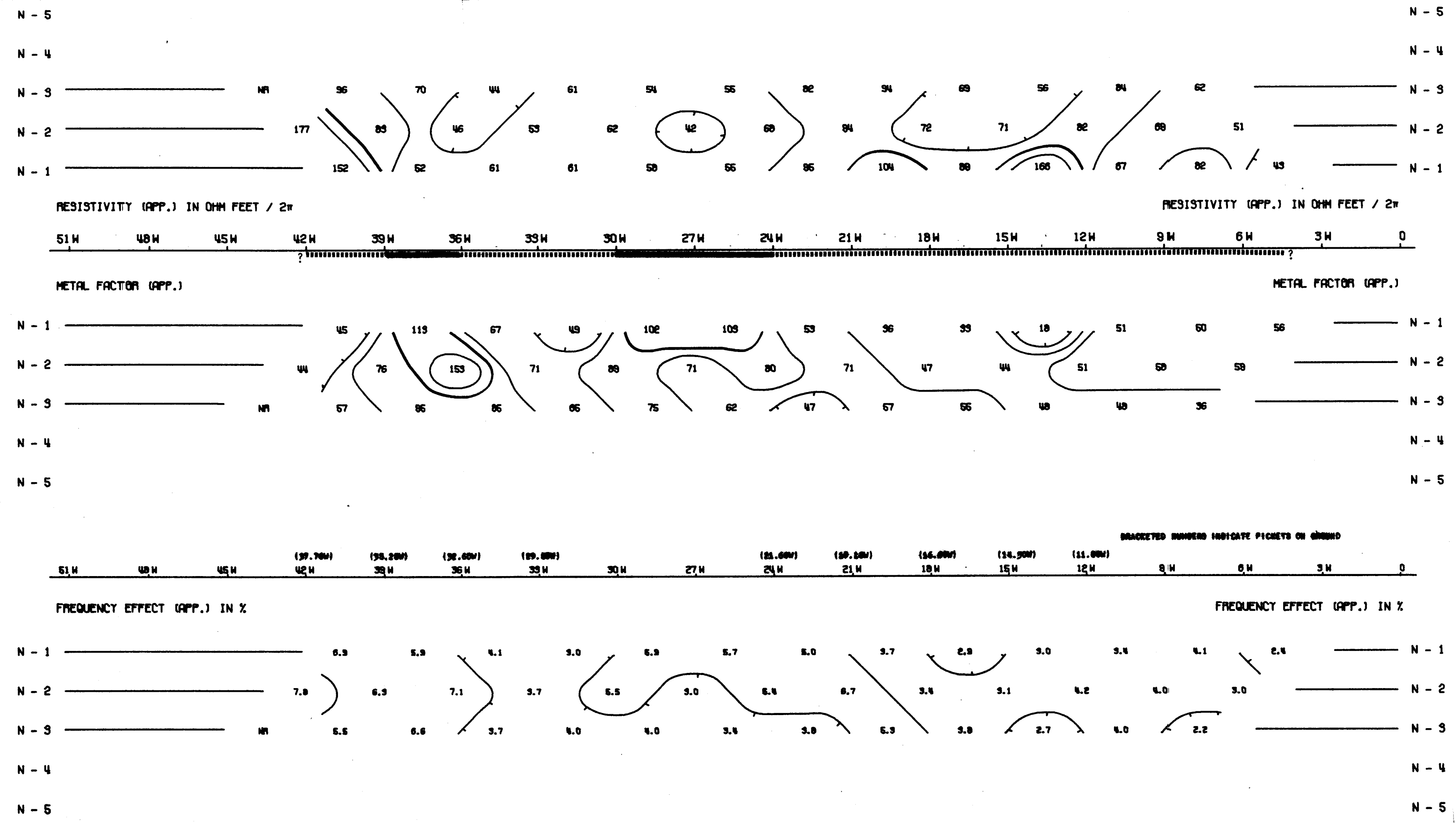

ISO EXPLORATIONS LTD.

KALCO VALLEY MINES LTD., (N.P.L.) OPTION,
SUMMERS CREEK VALLEY, TULAMEEN AREA,
SIMILKAMEEN M.D., BRITISH COLUMBIA.

LINE NO. - 800S

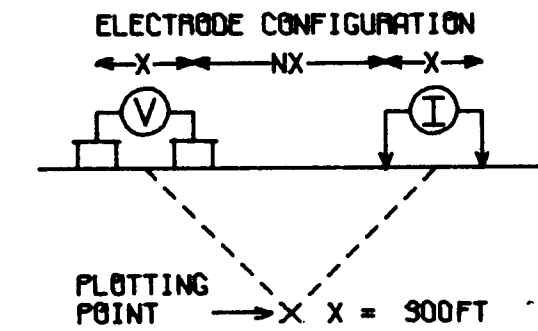

SURFACE PROJECTION
OF ANOMALOUS ZONES
DEFINITE
PROBABLE
POSSIBLE

FREQUENCIES: 0.31-5.0 HZ

DATE SURVEYED: AUG 1972

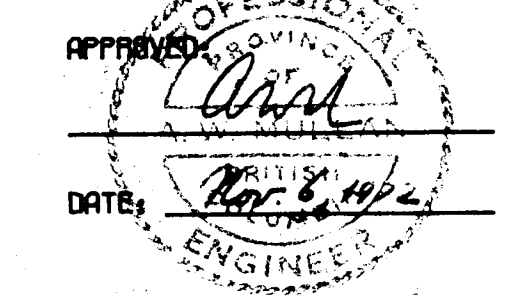

NOTE: CONTOURS AT
LOGARITHMIC INTERVALS
1.-1.5-2.-3.-5.-7.5-10

McPHAR GEOPHYSICS

INDUCED POLARIZATION AND RESISTIVITY SURVEY

NOTE: THIS PLOT WAS PRODUCED BY McPHAR COMPUTER DIVISION

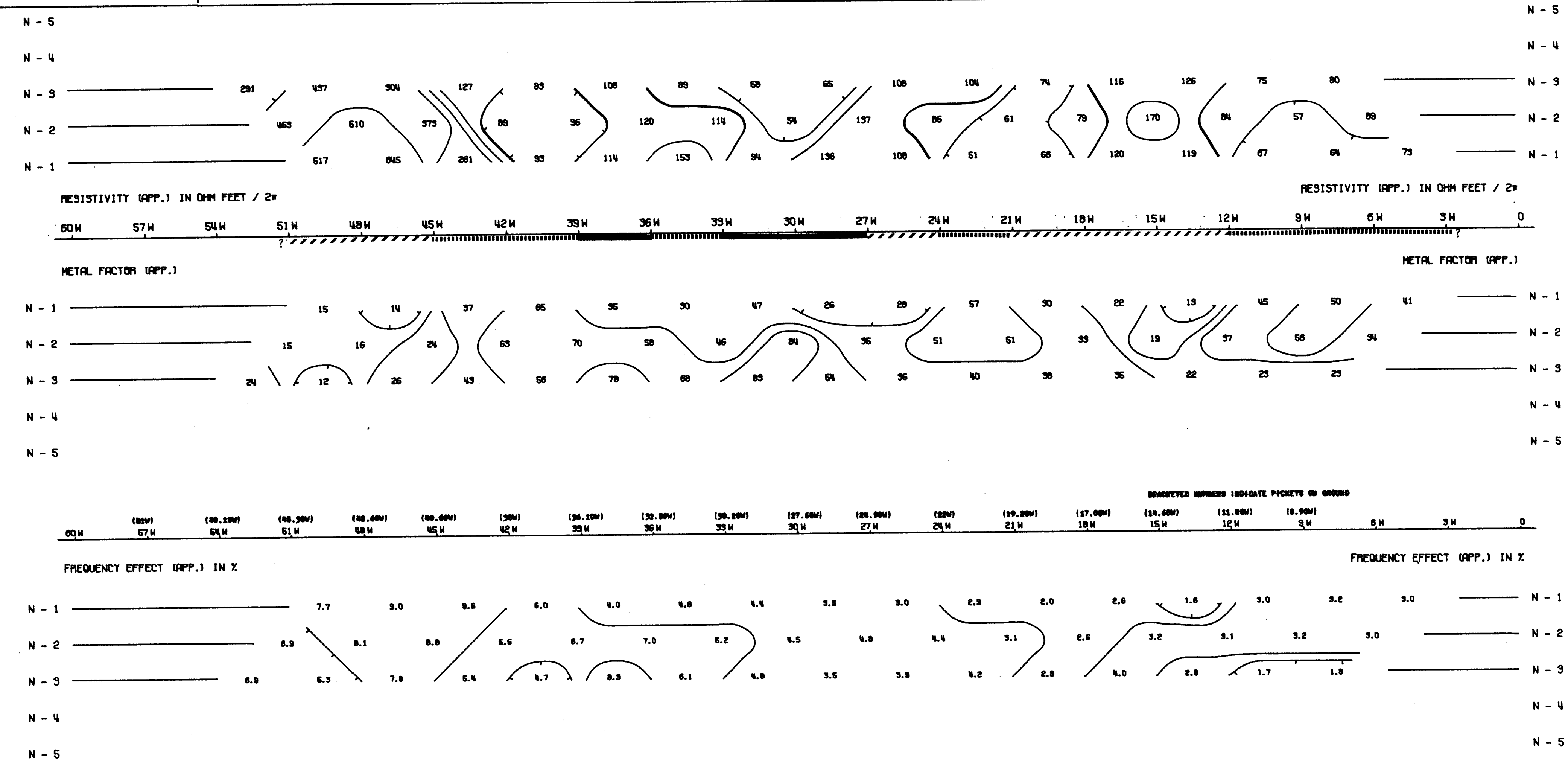

ISO EXPLORATIONS LTD.

KALCO VALLEY MINES LTD., (N.P.L.) OPTION,
SUMMERS CREEK VALLEY, TULAMEEN AREA,
SIMILKAMEEN M.D., BRITISH COLUMBIA.

LINE NO. - 4005

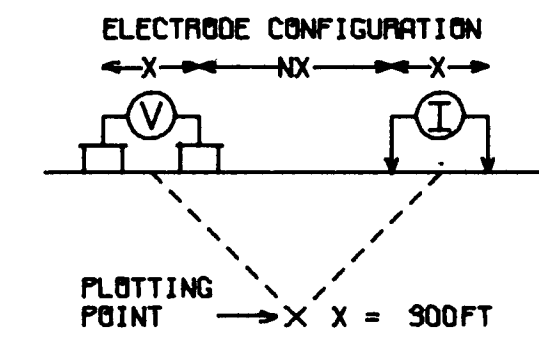

SURFACE PROJECTION
OF ANOMALOUS ZONES

DEFINITE
PROBABLE
POSSIBLE

FREQUENCIES: 0.31-5.0 HZ

DATE SURVEYED: AUG 1972

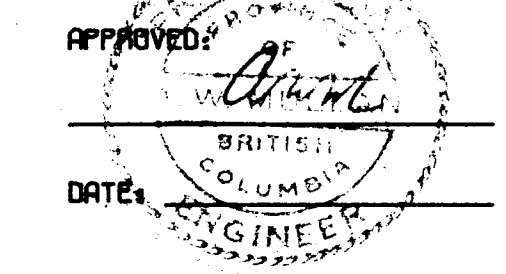

NOTE: CONTOURS AT
LOGARITHMIC INTERVALS
1.-1.5-2.-3.-5.-7.5-10

McPHAR GEOPHYSICS

INDUCED POLARIZATION AND RESISTIVITY SURVEY

NOTE: THIS PLOT WAS PRODUCED BY McPHAR COMPUTER DIVISION

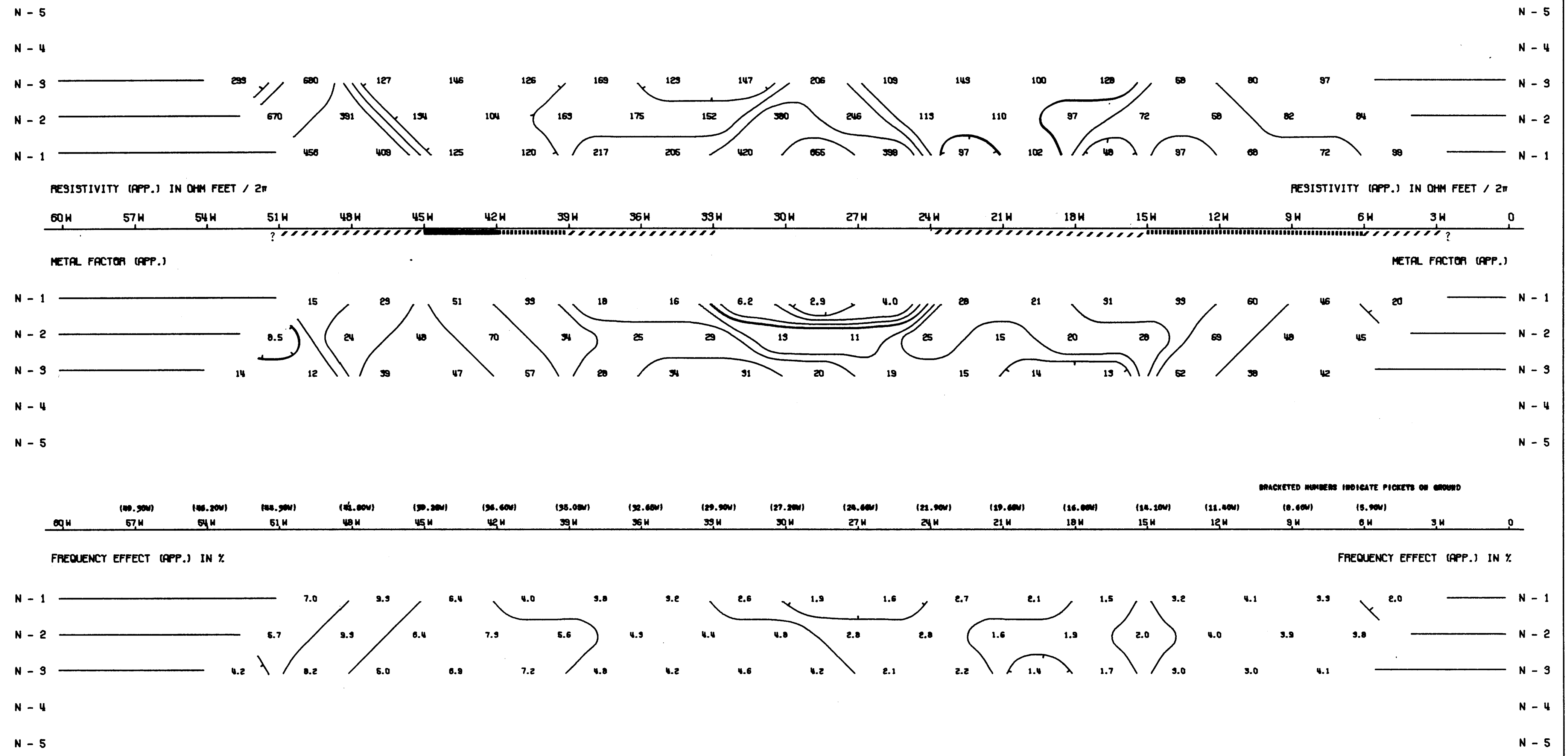

ISO EXPLORATIONS LTD.

KALCO VALLEY MINES LTD., (N.P.L.) OPTION,
SUMMERS CREEK VALLEY, TULAMEEN AREA,
SIMILKAMEEN M.D., BRITISH COLUMBIA.

LINE NO. - 0

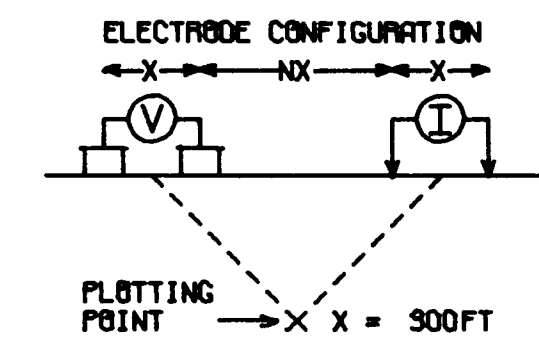

SURFACE PROJECTION
OF ANOMALOUS ZONES
DEFINITE **—————**
PROBABLE **|||||**
POSSIBLE **////**

FREQUENCIES: 0.91-5.0 HZ

DATE SURVEYED: AUG 1972

APPROVED: *[Signature]*
DATE: *Nov. 6/1972*
ENGINEER

NOTE: CONTOURS AT
LOGARITHMIC INTERVALS
1.-1.5-2.-3.-5.-7.5-10

McPHAR GEOPHYSICS

INDUCED POLARIZATION AND RESISTIVITY SURVEY

NOTE: THIS PLOT WAS PRODUCED BY McPHAR COMPUTER DIVISION

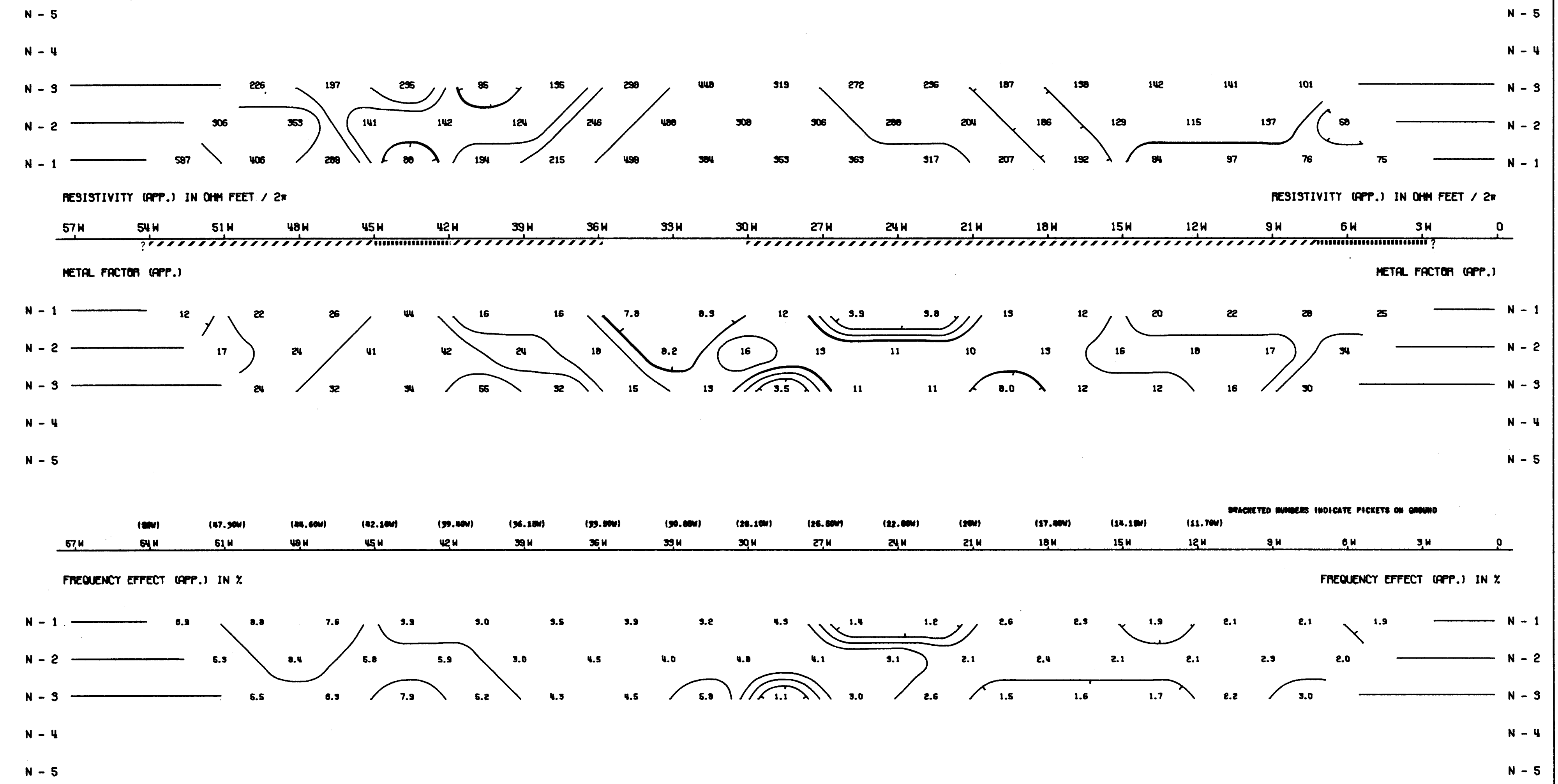

ISO EXPLORATIONS LTD.

KALCO VALLEY MINES LTD., (N.P.L.) OPTION,
SUMMERS CREEK VALLEY, TULAMEEN AREA,
SIMILKAMEEN M.D., BRITISH COLUMBIA.

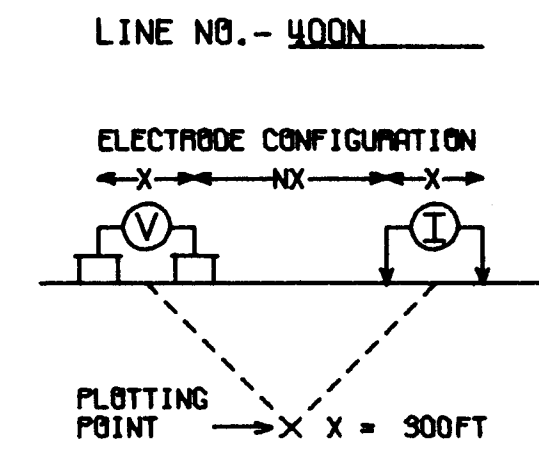

SURFACE PROJECTION
OF ANOMALOUS ZONES

DEFINITE **—————**

PROBABLE **|||||**

POSSIBLE **///////**

FREQUENCIES: 0.31-5.0 HZ

DATE APPROVED: AUG 1972



NOTE: CONTOURS AT
LOGARITHMIC INTERVALS
1.-1.5-2.-3.-5.-7.5-10

McPHAR GEOPHYSICS

INDUCED POLARIZATION AND RESISTIVITY SURVEY

NOTE: THIS PLOT WAS PRODUCED BY McPHAR COMPUTER DIVISION

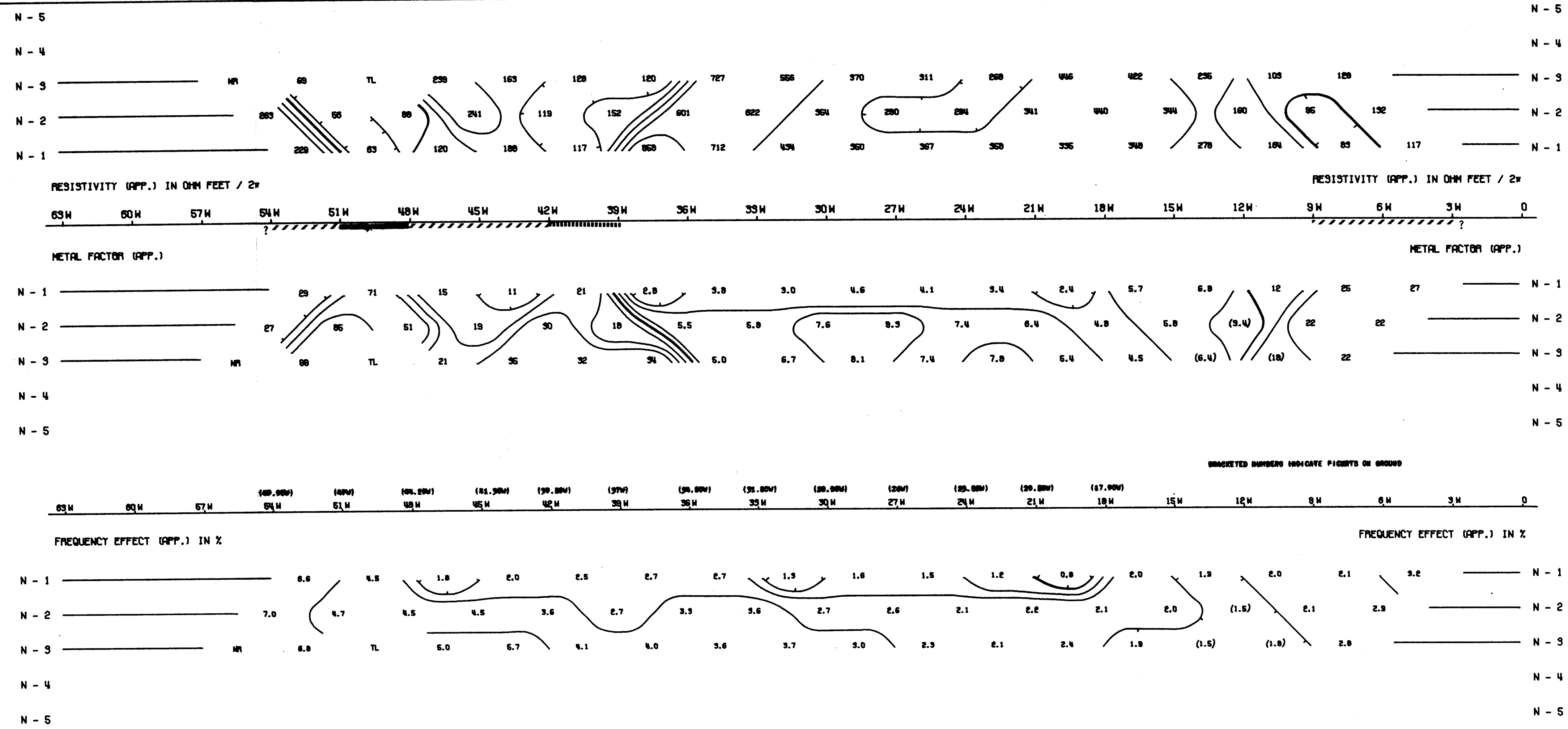

ISO EXPLORATIONS LTD.

KALCO VALLEY MINES LTD., (N.P.L.) OPTION,
SUMMERS CREEK VALLEY, TULAMEEN AREA,
SIMILKAMEEN M.D., BRITISH COLUMBIA.

LINE NO. - 800N

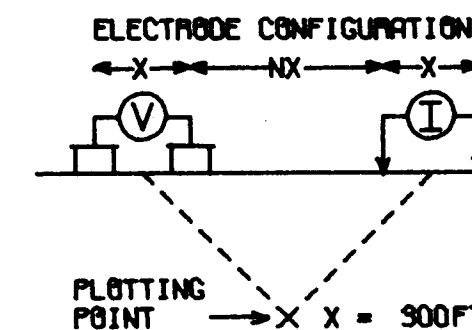

SURFACE PROJECTION
OF ANOMALOUS ZONES

DEFINITE
PROBABLE
POSSIBLE

FREQUENCIES: 0.31-5.0 HZ

DATE SURVEYED: AUG 1972

APPROVED



NOTE: CONTOURS AT
LOGARITHMIC INTERVALS
1.-1.5-2.-3.-5.-7.5-10

McPHAR GEOPHYSICS

INDUCED POLARIZATION AND RESISTIVITY SURVEY

NOTE: THIS PLOT WAS PRODUCED BY McPHAR COMPUTER DIVISION

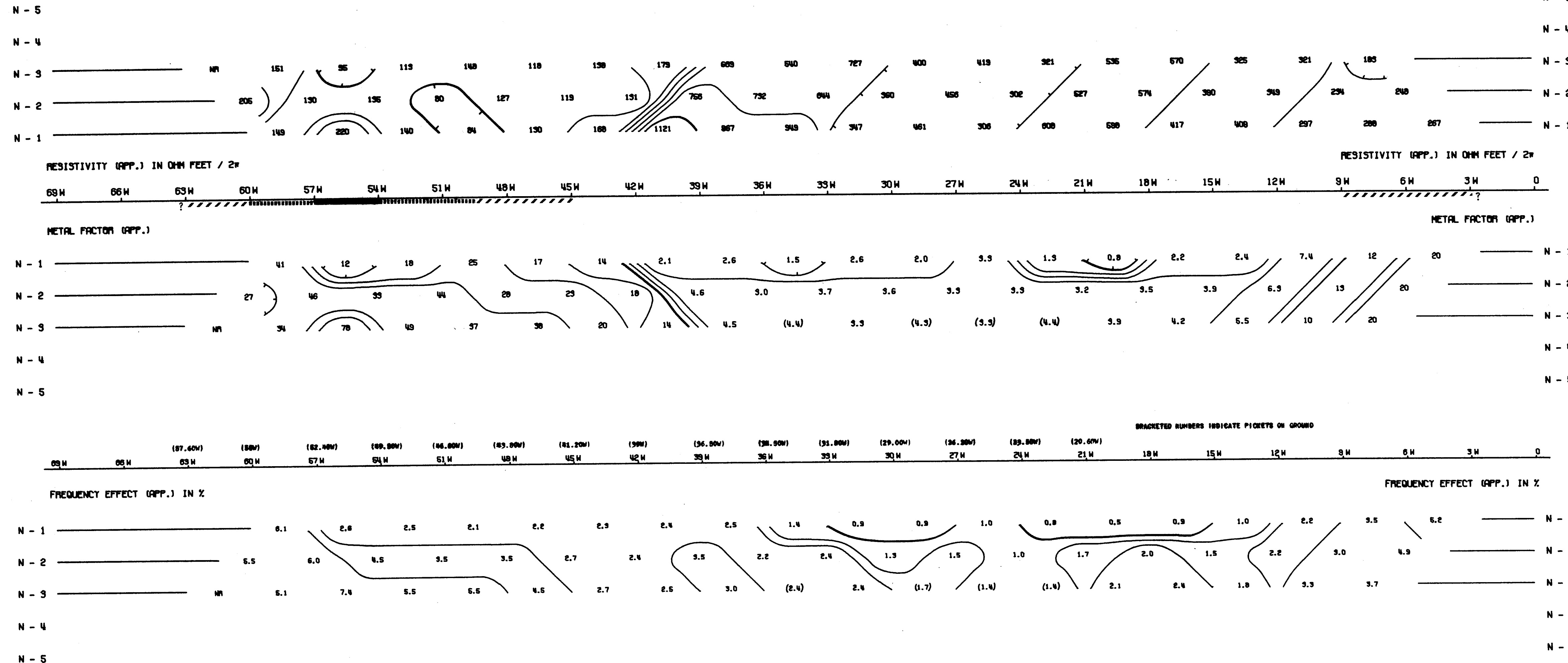

4166

DWG. NO. - I.P. - 6010-2

ISO EXPLORATIONS LTD.

KALCO VALLEY MINES LTD., (N.P.L.) OPTION,
SUMMERS CREEK VALLEY, TULAMEEN AREA,
SIMILKAMEEN M.D., BRITISH COLUMBIA.

LINE NO. - 1200N

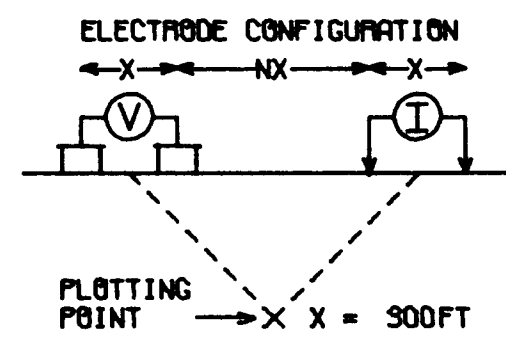

SURFACE PROJECTION OF ANOMALOUS ZONES

DEFINITE

PROBABLE

POSSIBLE

FREQUENCIES: 0.31-5.0 HZ

DATE SURVEYED: AUG 1972

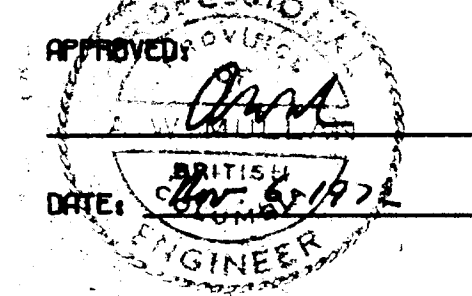

NOTE: CONTOURS AT LOGARITHMIC INTERVALS
1.-1.5-2.-3.-5.-7.5-10

McPHAR GEOPHYSICS

INDUCED POLARIZATION AND RESISTIVITY SURVEY

NOTE: THIS PLOT WAS PRODUCED BY McPHAR COMPUTER DIVISION

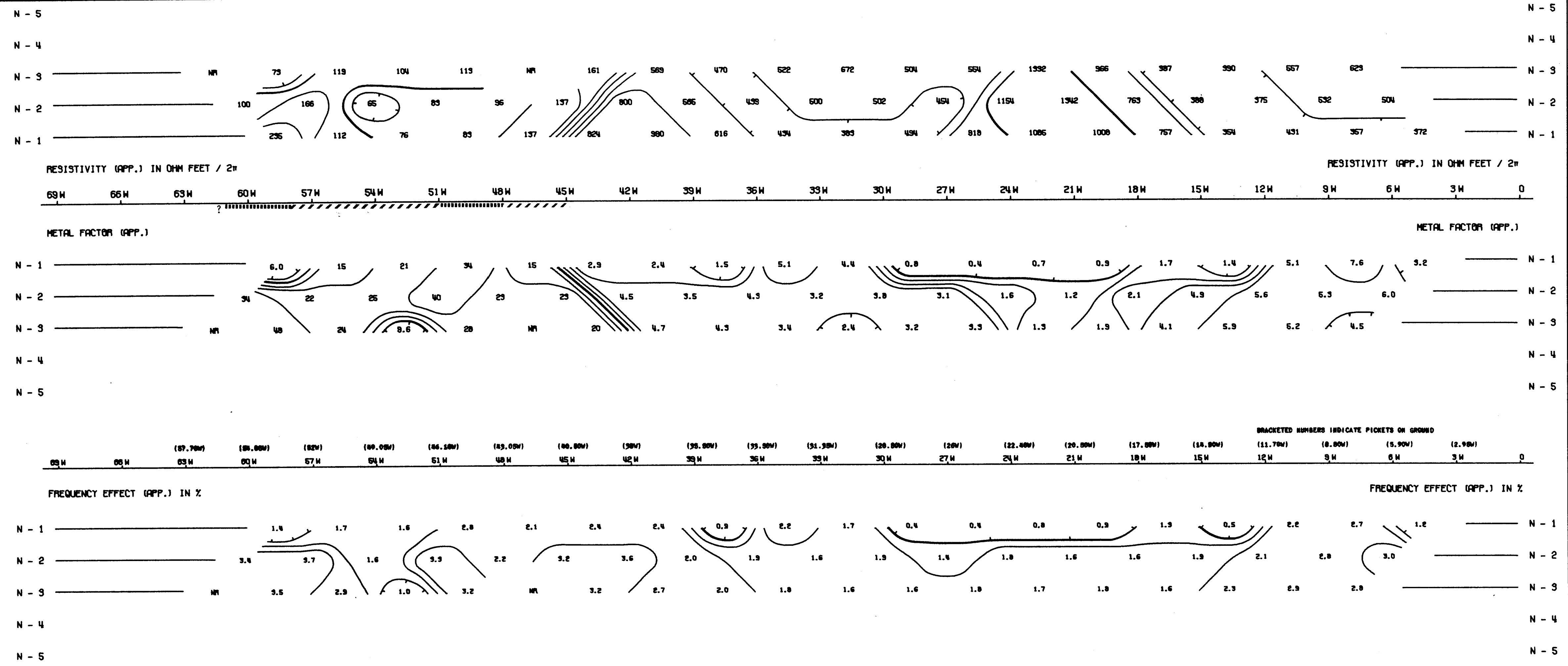

McPHAR GEOPHYSICS
INDUCED POLARIZATION AND RESISTIVITY SURVEY
PLAN MAP

Department of
Mines and Petroleum Resources
ASSESSMENT REPORT
NO. 4166 MAP #1

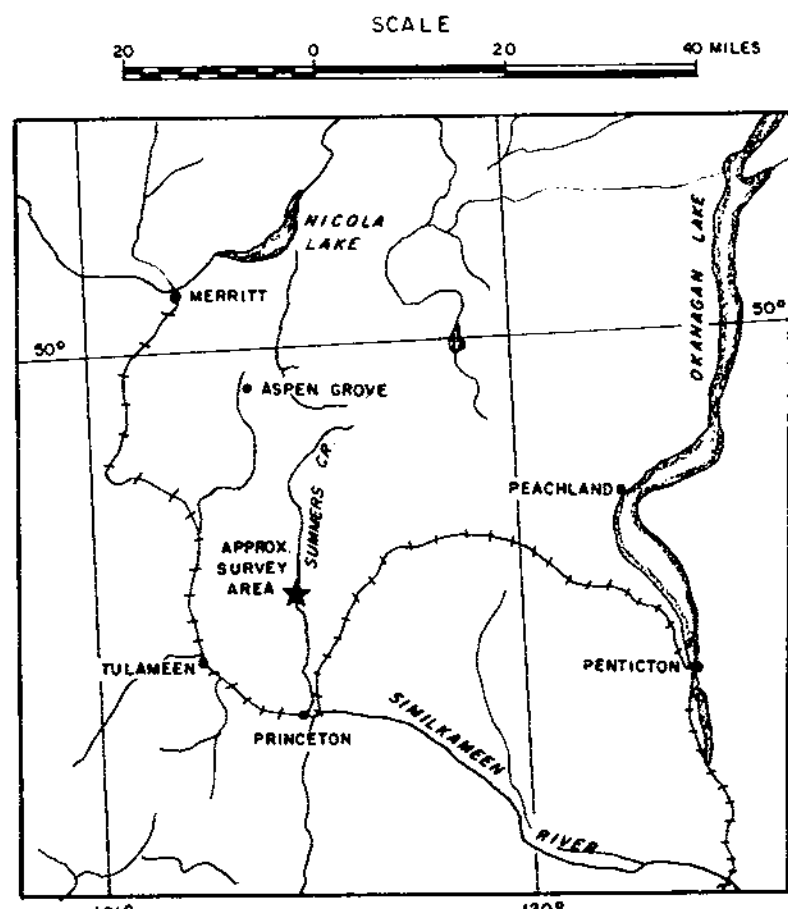
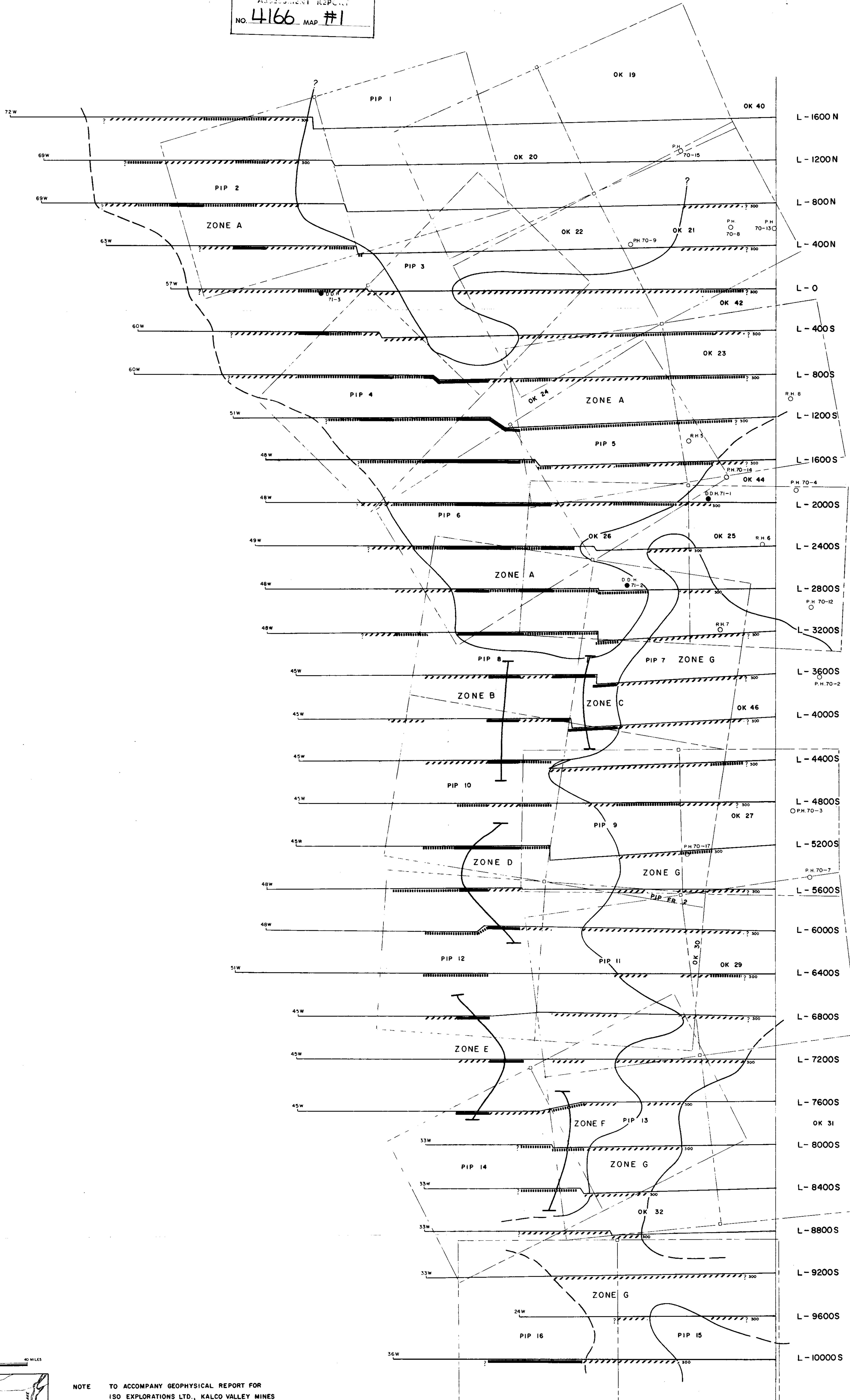

NOTE TO ACCOMPANY GEOPHYSICAL REPORT FOR
ISO EXPLORATIONS LTD., KALCO VALLEY MINES
LTD. (N.P.L.) OPTION, SIMILKAMEEN M.D.,
BRITISH COLUMBIA BY A.W. MULLAN (P.ENG)
AND M.A. GOUDIE (GEOLOGIST).
DATED: NOV. 6, 1972

4166 M-1

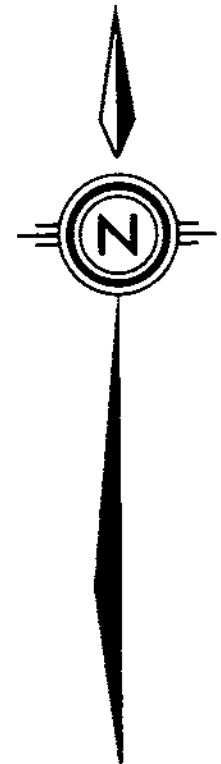

SURFACE PROJECTION
OF ANOMALOUS ZONES
DEFINITE
PROBABLE
POSSIBLE
Number at the end of anomaly
indicates electrode interval

ISO EXPLORATIONS LTD.
KALCO VALLEY MINES LTD. (N.P.L.) OPTION
SUMMERS CREEK VALLEY, TULAMEEN AREA
SIMILKAMEEN M.D., BRITISH COLUMBIA
SCALE
ONE INCH EQUALS FOUR HUNDRED FEET

(APPROX. LOCATION)
● DIAMOND DRILL HOLE
○ PERCUSSION HOLE
○ ROTARY HOLE
--- AZIS OF ANOMALOUS I.P. ZONE
--- BOUNDARY OF ANOMALOUS I.P. ZONE

DRAWN: B.L. [Signature]
DATE: [Signature]
A.W. MULLAN
BRITISH
ENGINEER
DATE: Nov. 6, 1972