

# 4867

## 82 E/8E

82E/8E 4867

REPORT ON  
INDUCED POLARIZATION SURVEY  
DEER PARK PROJECT  
CASTLEGAR AREA, BRITISH COLUMBIA  
ON BEHALF OF  
AMAX EXPLORATION INC.

BY:

Michael J. Lewis, M.Sc., P.Eng.  
Geophysicist

Paul R. Bailey, M.Sc., D.I.C.  
Geophysicist

Jan Klein, M.Sc., P.Eng.  
Geophysicist

Dates:

October 19th - November 8th, 1973

Dated:

January 7th, 1974

Department of	
Mines and Petroleum Resources	
ASSESSMENT REPORT	
NO. 4867	MAP

CONTENTS

	<u>Page No.</u>
SUMMARY	
INTRODUCTION	1
METHOD AND INSTRUMENTATION	2
GENERAL GEOLOGY	3
PRESENTATION OF RESULTS	4
DISCUSSION OF RESULTS	4
CONCLUSIONS AND RECOMMENDATIONS	7

SPECIFICATION SHEETS:

Scintrex Mark VII Induced Polarization Systems  
Induced Polarization Method by H. O. Seigel 1970

FIGURES AND PLATES

#1 Figure 1 - Location Map	Scale 1:250,000
#2 Figure 2 - Claim Map	Scale 1" = 2000'
Figure 3 - Pole-Dipole Array	
#3 Plate 1 - Chargeability Contour Plan	Scale 1" = 200'
#4 Plate 2 - Resistivity Contour Plan	Scale 1" = 200'
#5-7 Plates 3, 4, 5 - Pseudo Sections	Scale 1" = 200'
#8 Plate 6 - Anomalous Zone Plan	Scale 1" = 200'
#9 Linecutting	

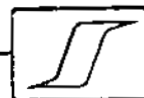

SUMMARY

The present induced polarization and resistivity survey has revealed four anomalous zones.

Five diamond drill holes totalling 2000 feet in length have been recommended as the minimum requirement to test the sources of these anomalies.



REPORT ON  
INDUCED POLARIZATION SURVEY  
DEER PARK PROJECT  
CASTLEGAR AREA, BRITISH COLUMBIA  
ON BEHALF OF  
AMAX EXPLORATION INC.

INTRODUCTION

During the period October 19th - November 8th, 1973, an Induced Polarization survey was carried out on the Deer Park Property, Castlegar, B. C. by Scintrex Surveys Limited on behalf of Amax Exploration Inc. The survey crew was under the direction of Mr. Tony Guernier.

The property is located in the southern part of the Monashee Range in southeastern B. C. as shown in Figure 1. It lies approximately 230 miles east of Vancouver and 20 miles north of the U.S. border (coordinates 118° 02' W, 49° 20' N). Topographically the property is situated in a saddle near the head waters of Shields Creek at elevations ranging from 3500 feet to 5500 feet.

Logging roads which branch northwards from Highway #3 near the summit between Castlegar and Grand Forks come within one mile of the property. Final access is via a four wheel drive along a dirt road which terminates on the grid.

Figure 2 shows the claims covered, in whole or in part, by the Induced Polarization Method, namely:

- CAMEL 1, 2, 3, 5, 18, 20, 36
- DEER 12, 14, 27, 28, 29, 31, 33, 34
- DEER Fr.
- P. 5 Fr.

The survey consisted of fourteen lines striking north-south with interline spacings of 400 feet. Lines are designated L-58 E, L-62 E .... L-110 E. The picket interval was 100'. A total of approximately 9 linear

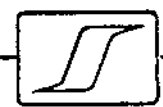

miles of geophysical coverage were obtained.

#### METHOD AND INSTRUMENTATION

A Scintrex Mark VII 2.5 kw time-domain induced polarization unit was utilized on the present survey. This unit has a current "on" time of 2.0 seconds and a current "off" (potential measuring time) of 2.0 seconds. The polarization/transient voltages are integrated between the .45 to 1.1 second part of the "off" cycle and normalized to the "on" cycle voltage at the receiver. The resulting Chargeability, in milliseconds, is a measure of the induced polarization effect. The Resistivity, in ohm-meters, of the rocks in the measurement zone, is computed from the formula  $R = CV_p/I$  where  $V_p$  = on cycle voltage at the receiver,  $I$  = current output from the transmitter,  $C$  = a constant depending on the array geometry.

For the present survey the Pole-Dipole Array was employed. This array is shown schematically below in Figure 3.

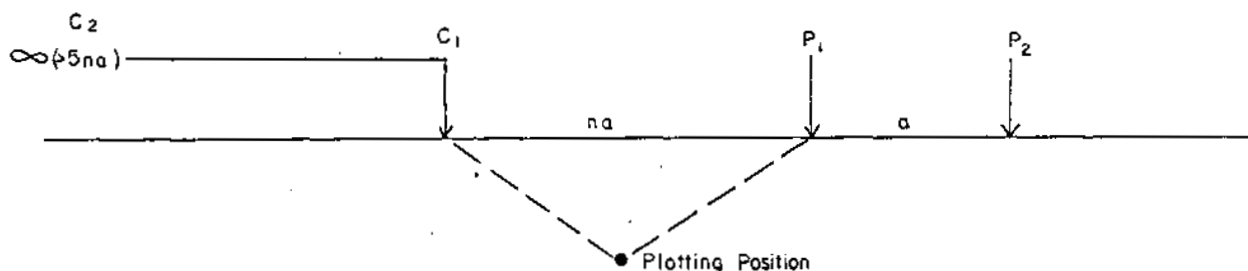

Figure 3

Spacings of  $a = 200'$ ;  $n = 1, 2, 3, 4$  and  $5$  were utilized. Readings were taken at intervals of  $200'$ .

The plotting point for the Pole-Dipole Array is taken as the midpoint between the  $C_1$  and  $P_1$  electrodes (see Figure 2). Topographic variations and geological inhomogenities may result in the centre of the anomalous zone being shifted from its apparent location using this midpoint convention.



Induced polarization responses may arise from metallic or non-metallic agencies. The former include most sulphides (except sphalerite), arsenides, a few oxides such as magnetite and, unfortunately, graphite. Non-metallic sources include alteration minerals such as sericite, chlorite, serpentinite and some clay minerals. There is no reliable criterion for differentiating between over-voltage responses from metallic or non-metallic minerals or for distinguishing between the responses of one type of sulphide and another.

A more details description of the induced polarization method is contained in the attached copy of H. O. Seigel's paper entitled "Induced Polarization Method" dated 1970.

#### GENERAL GEOLOGY

The following description of the geology of the property was supplied by Mr. G. M. DePaoli of Amax Exploration Inc.

"The Deer Park Molybdenite Property is underlain by rocks which are mainly intrusive, tentatively dated as Paleocene and known as the "Coryell Intrusions". They consist of syenites, monzonites, shonkinites and granites.

It is postulated that all of the rocks within the property were formed as a result of the emplacement of a monzonitic intrusion. Variations of the intrusion due to margin effects, differentiation and brecciation resulted in several rock types of similar composition but of different textures.

Minerals occurring on the property include pyrite, magnetite, hematite, molybdenite, chalcopyrite and fluorite. These minerals are generally found in quartz veins, shear zones and brecciated areas within the monzonite.

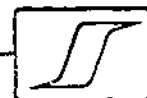

Significant molybdenum values were obtained from one pyritized breccia zone straddling the base line near 76 + 00 E. The induced polarization survey was undertaken to further define the depth and distribution of the mineralization associated with this breccia and test the remainder of the grid for similar zones".

#### PRESENTATION OF RESULTS

Plates 1 and 2 are contour plans of the  $n = 3$  Chargeability and Resistivity values respectively plotted on the uniform scale of  $1'' = 200'$ . The contour intervals are 2.0 milliseconds and 100 ohm-meters. Plates 1 and 2 also show the grid configuration, the disposition of claims and some and topographic features.

Plates 3, 4 and 5 contain Pseudo-Sections of the geophysical data - scale  $1'' = 200'$ .

Plate 3 covers Lines 58 E, 62 E, 66 E and 70 E

Plate 4 covers Lines 74 E, 78 E, 82 E and 86 E

Plate 5 covers Lines 90 E, 94 E, 98 E, 102 E, 106 E and 110 E.

Interpretative designation and/or anomaly symbols are shown on all plates.

#### DISCUSSION OF RESULTS

Apparent resistivities over the whole grid were relatively high and away from inhomogenities were typically in the range 1500 to 3500 ohm-meters. No appreciable increase in resistivity with increasing "n" number was noted and it can be concluded that the overburden was negligably thin in relation to the 200 foot "a" spacing. The chargeability background was also relatively high being in the 15.0 to 25.0 millisecond range. High



chargeabilities such as these are to be expected over highly resistive ground on account of the larger decay time constant being introduced by the resistive, rather than a capacitive, component. Thirty milliseconds was taken as the approximate anomalous threshold.

Four distinctly anomalous zones, labelled A, B, C and D, were detected and are shown on Plate 6.

Zone A strikes approximately west-northwest across the grid in what has been noted as two separate, parallel bands of the same source. There may, however, be two different sources: one to the south with an axis extending from grid coordinates 71 E, 61 + 50 N and open to the west-northwest; the northern part of Zone A is centered on Line 74 at Station 71 N and to the west extends parallel to the southern part of Zone A. This northern part is also open to the west. To the east of the center of the northern part the zone extends to the northeast in the direction of Zone B. Double-peaking from both bands of Zone A appears to be present and the responses from both sources have interfered so that interpretations assuming a single body source may be somewhat erroneous. Over the center of the northern part of Zone A, i.e. Line 74 E between Stations 65 N and 77 N the clear-cut, text book-like double peaking that exists appears to be due to a body approximately 200 feet wide centred at Station 70 + 75 N. Twin peaks are present on the  $n = 1$  spacing indicating that the depth extent of the body at this location is less than 200 feet. The bulk of the source material at this location consequently appears to be reasonably well confined. A fault or contact may mark the bottom of the source. The Pseudo-Section from the same body on Line 70 E is more complicated than that on Line 74 E and probable boundaries are more difficult to distinguish. The southern edge of the center of this same source on Line 70 E appears to be located





at approximately Station 71 N but the northern boundary is not as clearly defined compared to the northern extent on Line 74 E.

The southern part of Zone A on Line 70 E between Stations 61 N and 62 N also appears to be of relatively shallow depth extent. The data here, however, is ambiguous as the lower amplitude northern peaks, which would have developed with the potential dipole north of the moving current electrode had a chargeable source not existed to the north, appear to have been swamped by the response from the larger amplitude peaks on the southern edge of the body to the north. Although on the anomalous zone plan, Plate 6, the two definitely anomalous parts of Zone A are separated by a zone of possible interest on Line 70 E, it is possible that two distinct and separate sources exist here. In fact the southern part of Zone A (south of the possibly anomalous zone) may be a separate source all along its strike length. Although both parts of Zone A are open to the west-northwest, anomalous amplitudes are significantly decreased at Line 58 E.

The remaining three Zones, B, C and D are considered to be of lower priority interest compared to Zone A.

On Plate 6, Zone B is centered at grid coordinates 82 E, 84 N and exhibits a maximum anomalous response of 33.0 milliseconds (with the  $n = 1$  spacing) on Line 82 E at Station 85 N. Chargeability amplitudes decrease steadily to a non-anomalous level with increasing "n" spacing although chargeabilities between Zones A and B are consistently high.

Zone C, centered on Line 90 E at Station 66 N, is situated along strike from the axis of the source of the northern part of Zone A and possibly correlates with this as a small zone of minor interest is located between Zones A and C on Line 86 E at Station 65 N. Double peaks are noted on the  $n = 2$  and  $n = 3$  spacings which were not present on the first

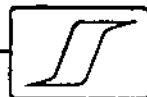

spacing. This may indicate a depth extent of less than 400 feet for this body. The n = 1 spacing reaches a maximum anomalous peak of over 37.5 milliseconds on Line 90 E at Station 66 N which is approximately twice the local background.

Zone D, centered on Line 106 E at Station 73 N, attains a maximum response with the n = 1 spacing of 39.0 milliseconds on Line 106 E at Station 71 N. The zone is coincident with a stream which may indicate the presence of a fault at this location. On the adjacent lines the zone is of possible interest at the following centers: Line 102 E at Station 75 + 50 N and on Line 110 E at Station 72 N.

CONCLUSIONS AND RECOMMENDATIONS

The present induced polarization survey has resulted in the detection of four zones of anomalous chargeability. Both bands of Zone A are open grid west.

The bulk of the sources of all zones appear to be within well defined boundaries and within Zone A the depth extent of the greatest concentration of the source appears to be relatively shallow.

Should geological and geochemical considerations provide favourable correlation with the geophysical data the following drill holes are tentatively recommended to sample selected zones of peak chargeability responses:

ZONE A

- DDH #1 - Collar on grid coordinates 66 E, 69 N. Drill grid 205° at 45° for a distance of 400 feet.
- DDH #2 - Collar on grid coordinates 76 E, 72 N. Drill grid 200° at 45° for a distance of 400 feet.

Although in between two lines, this collar location is conveniently located on the road and is considered the optimum position for testing the zone peak.

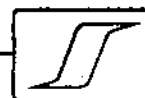

ZONE B

DDH #3 - Collar on Line 82 E at Station 85+50N. Drill grid 150° at 45° for a distance of 400 feet.

ZONE C

DDH #4 - Collar on Line 90 E at Station 68+50N. Drill grid south at 45° for a distance of 400 feet.

ZONE D

DDH #5 - Collar on grid co-ordinates 106E, 74+50N. Drill grid 205° at 45° for a distance of 400 feet.

At the discretion of the client, collar location and/or drill angles may be changed to allow for local access conditions.

Additional drilling and/or geophysical coverage would be dependent upon the results of this initial programme.

Respectfully submitted,

SCINTREX SURVEYS LIMITED

*Paul R. Bailey*

*Per  
Am.* Paul R. Bailey, M.Sc., D.I.C.  
Geophysicist

*Michael J. Lewis*

*Per  
Am.* Michael J. Lewis, M.Sc., P. Eng.  
Geophysicist

*Jan Klein*

Jan Klein, M.Sc., P. Eng.  
Geophysicist

Engr. Reg. No. 1374

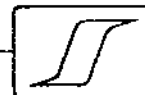

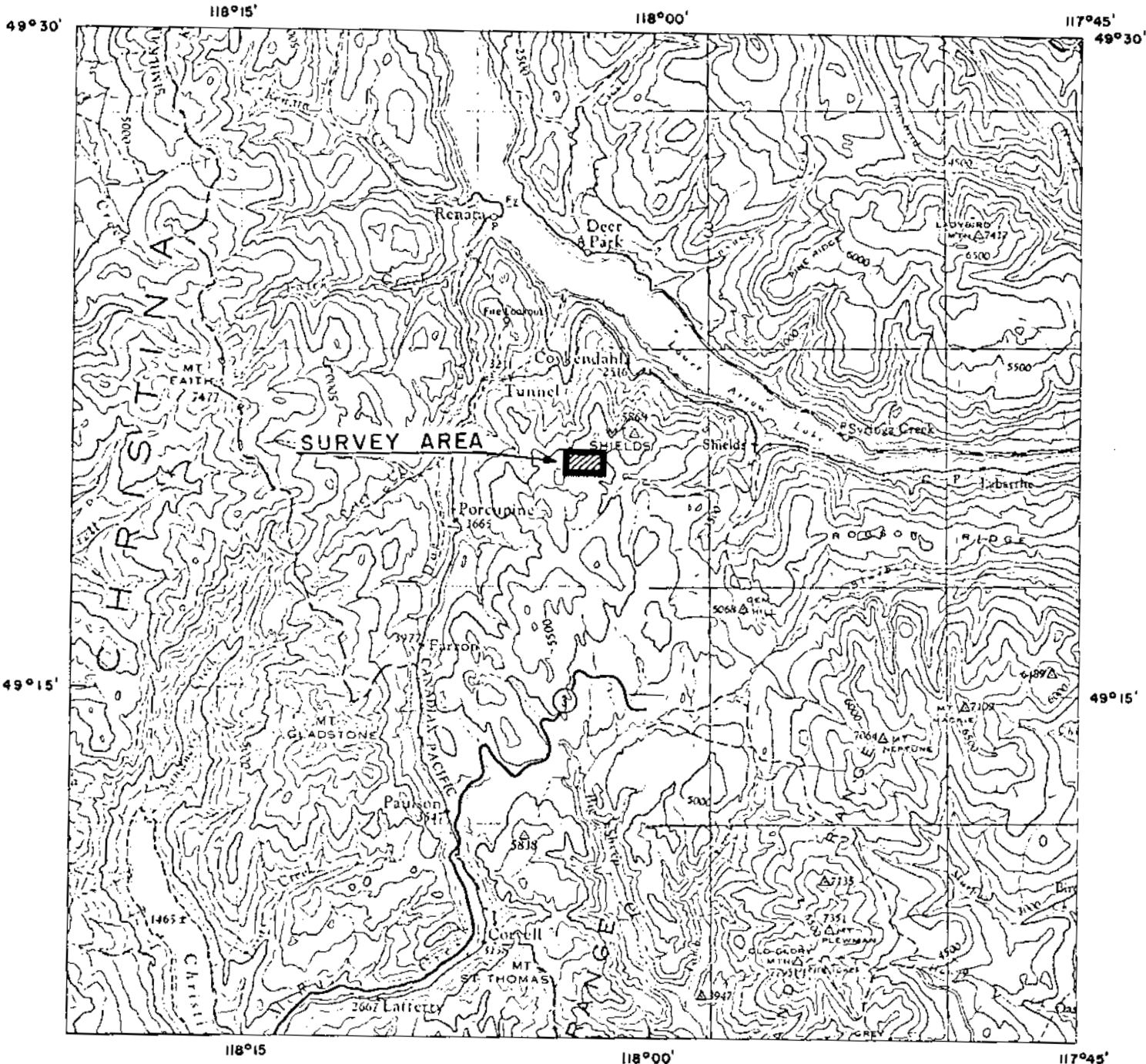

LOCATION MAP

AMAX EXPLORATION INC.

DEER PARK PROPERTY, CASTLEGAR AREA, B.C.

GROUND GEOPHYSICAL SURVEY

73 - 9693 V

Scale: 1: 250,000

Map No. 4867 MAP #1

NO. **4867** MAP # **1**

Figure 1

*[Handwritten signature]*

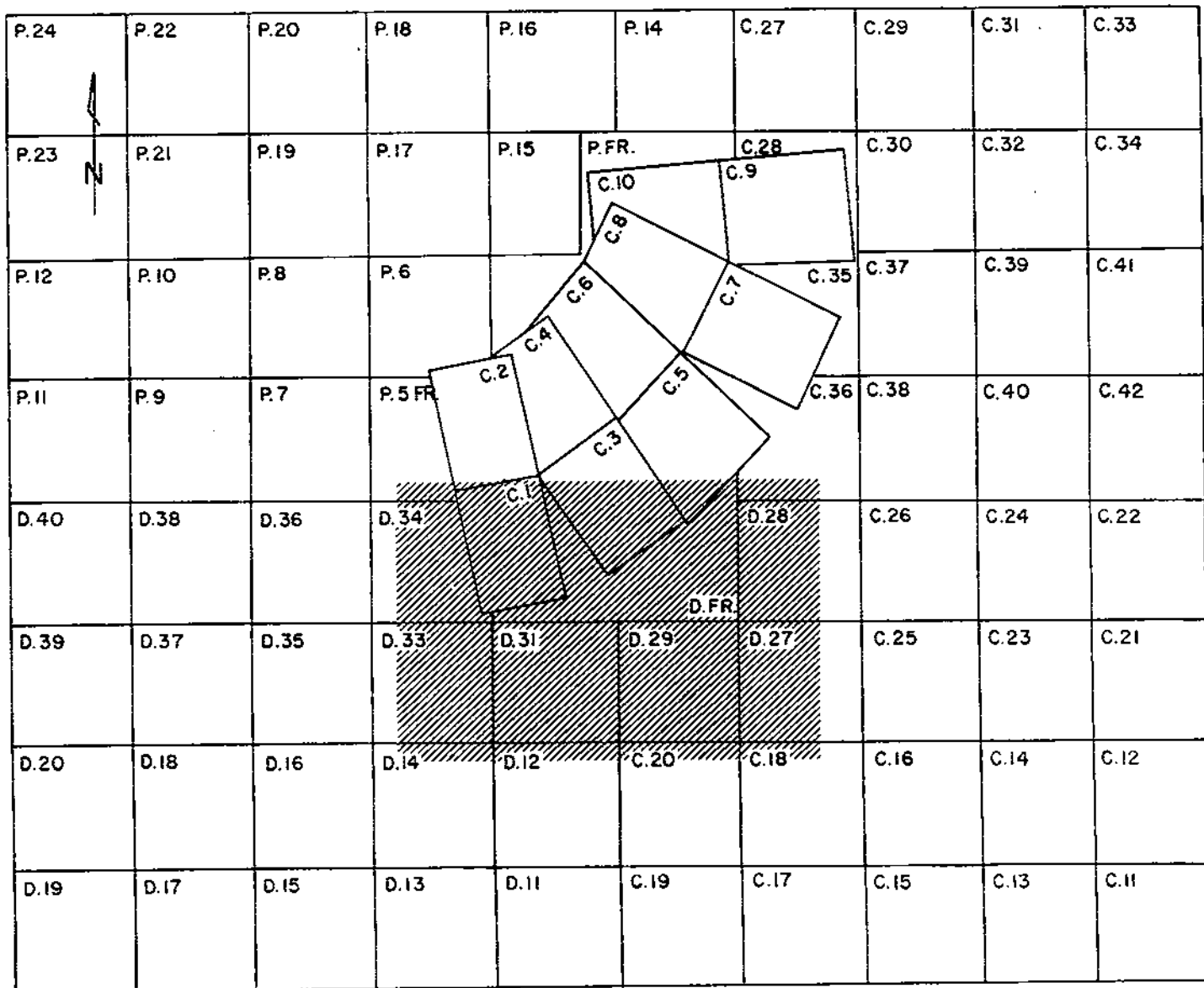

AMAX EXPLORATION INC.  
 DEER PARK PROPERTY, CASTLEGAR AREA, B.C.

**CLAIM MAP**

Mines and Resources Act  
 Scale 1" = 2000'  
 DATE NOV. 1973

NO. **4867** # **2**

D. \_\_\_\_\_ DEER  
 P. \_\_\_\_\_ PARK  
 C. \_\_\_\_\_ CAMEL  
 // \_\_\_\_\_ SURVEY AREA

*[Handwritten Signature]*

Figure 2

DOMINION OF CANADA:  
PROVINCE OF BRITISH COLUMBIA.  
To Wit:

In the Matter of a geophysical survey on behalf of  
Amax Exploration Inc.

I, L. A. Merrifield for Scintrex Surveys Limited

of #750 - 890 West Pender Street, Vancouver

in the Province of British Columbia, do solemnly declare that an induced polarization survey has been executed on some DEER, PARK and CAMEL claims, Castlegar area, British Columbia between October 19th, 1973 to November 8th, 1973. The following expenses were incurred:

(1) Wages:

T. Guernier	21 days @ \$40.00/day	\$840.00
J. Carver	21 days @ \$25.00/day	\$525.00
N. Rebalski	21 days @ \$25.00/day	\$525.00
D. Smith	21 days @ \$25.00/day	\$525.00
J. Stump	21 days @ \$25.00/day	<u>\$525.00</u>

\$2,940.00

(2) Transportation & shipping to the job

\$252.00

(3) Food & living expenses

\$762.41

(4) Use of geophysical equipment.

21 days @ \$60.00/day

\$1,260.00

(5) Paid to Scintrex Surveys Limited to cover geophysicist's supervision, calculating, plotting and fairdrawing data and preparation of final reports

\$3,075.59

\$8,290.00

And I make this solemn declaration conscientiously believing it to be true, and knowing that it is of the same force and effect as if made under oath and by virtue of the "Canada Evidence Act."

Declared before me at the City  
of Vancouver, in the  
Province of British Columbia, this 11th  
day of February, 1974, A.D.

*L. A. Merrifield*

*John J. ...*  
A Commissioner for taking Affidavits for British Columbia or  
A Notary Public in and for the Province of British Columbia.

SUB-MINING RECORDER

## ACCESSORIES AND OPTIONS AVAILABLE

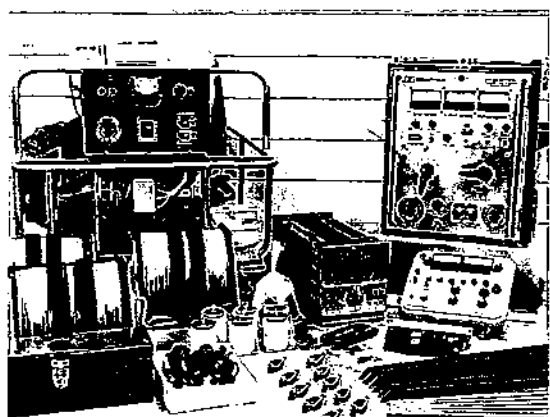
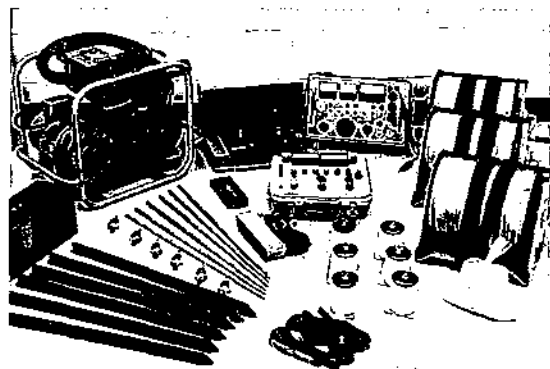

### 25 w Transmitter

- S Double reel DR 3020
- S 2000' I.P. wire
- S Porous pots with electrodes
- S Tee Stakes
- S Stainless steel stakes
- S Supercon plug
- S Alligator clips
- S Copper sulphate 2 lbs. polybag

### 2.5 kw Transmitter

- O Spare parts kit, Major
- O Back pack
- O Walkie talkies
- O Stainless steel stakes (for winter operation)
- S Reel SR 4020
- S 3500' I.P. wire
- S Stainless steel stakes
- S Porous pots with electrodes
- S Alligator clips
- S Joy plugs
- S Copper sulphate 2 lbs. polybags

### 10 kw Transmitter

- O Spare parts kit, Major
  - O Walkie talkies
  - O Stainless steel stakes (for winter operation)
  - S Reel SR 4020
  - S 3500' I.P. wire
  - S Stainless steel stakes
  - S Porous pots with electrodes
  - S Tee Stakes
  - S Supercon connector
  - S Alligator clips
  - S Copper sulphate 2 lbs. polybag
  - S Tool box
- (S: Standard, O: Optional)

## BRANCH OFFICES AND SUBSIDIARIES

### SCINTREX LIMITED

(Scintrex Instruments Division)  
222 Snidercroft Road  
Concord, Ontario

### SCINTREX INC.

Amherst Industrial Park  
Creekside Drive  
Tonawanda (Buffalo) New York 14150

### SEIGEL ASSOCIATES LIMITED

222 Snidercroft Road  
Concord, Ontario

### SEIGEL ASSOCIATES LIMITED

750 — 890 West Pender Street  
Vancouver, British Columbia

### SEIGEL ASSOCIATES LIMITED

Suite 202, 528 — 9th Avenue S.W.  
Calgary, Alberta

### MINERAL SURVEYS INC.

Amherst Industrial Park  
Creekside Drive  
Tonawanda (Buffalo) New York 14150

### SCINTREX AIRBORNE GEOPHYSICS INC.

4425 — East 31st Street  
Tulsa, Oklahoma, 74135

### SEIGEL ASSOCIATES (JAMAICA) LTD.

P.O. 627, 30 Duke Street  
Kingston, Jamaica

### SEIGEL ASSOCIATES (INTERNATIONAL) LTD.

P.O. Box 627, 30 Duke Street  
Kingston, Jamaica

### SEIGEL ASOCIADOS, S.A. de C.V.

Cerro de San Francisco 221  
Mexico 21 D.F., Mexico

### MINERAL SURVEYS INC.

(Western Division)  
178 West 2950 South  
Salt Lake City, Utah, 84115

### SEIGEL ASSOCIATES AUSTRALASIA PTY. LTD.

11 King Street  
Boulder, West Australia, 6432



# SCINTREX LIMITED

222 Snidercroft Road · Concord, Ontario, Canada



# SCINTREX

# MK VII INDUCED POLARIZATION SYSTEMS

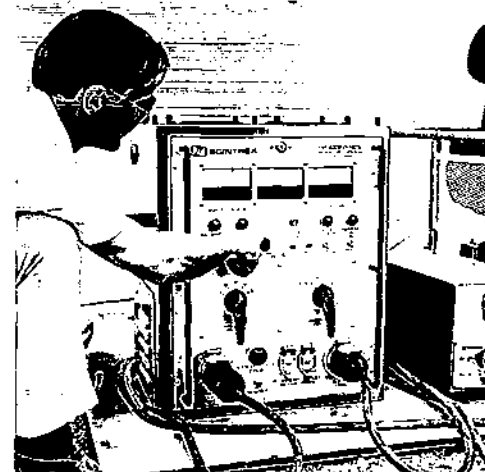

Scintrex Induced Polarization Units employ the time domain method of measurement, which is more sensitive and accurate than the frequency domain type. Through the use of solid state, primarily integrated circuits, the weight of both control and measuring units has been substantially reduced. The latest I.P. system offers a choice of 3 control units of the IPC-7 series and includes the IPR-7 Newmont type receiver.

The field mobility and flexibility of I.P. measurements have now been increased since no direct cable connection is required between the transmitter and the self-triggering receiver. Further advantages of the IPR-7 are the automatic self-potential compensation, automatic summation of any desired number of polarization signals and a built-in a.c. noise filter. Due to the inherent noise suppression capability of this system, I.P. surveys can be conducted closer to sources of spurious electrical noise, such as power lines or mines. The receiver cannot be falsely triggered by a short duration electrical pulse. The direct reading of chargeability enables even a relatively inexperienced operator to recognize an anomaly immediately.

The 25 w control unit and IPR-7 receiver together weigh less than 25 lbs. and are suitable for near surface measurements, such as an extension of surface showing and rapid reconnaissance in rugged terrain. The wide operating temperature range from  $-20^{\circ}\text{F}$  to  $130^{\circ}\text{F}$  makes it possible to survey in all climatic zones.

### ILLUSTRATIONS:

Top: IP-25 w System — lightweight and portable.  
Center: In-situ calibration of IPR-7 receiver.  
Bottom: IPC-7/10 kw Transmitter.

# 3

## CONTROL UNITS TO CHOOSE FROM IN THE IPC-7 SERIES....

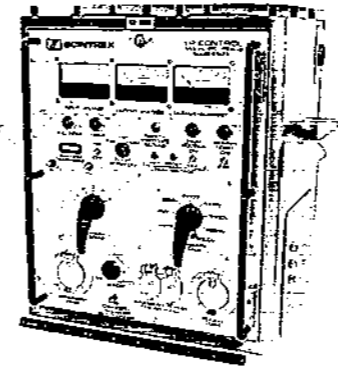
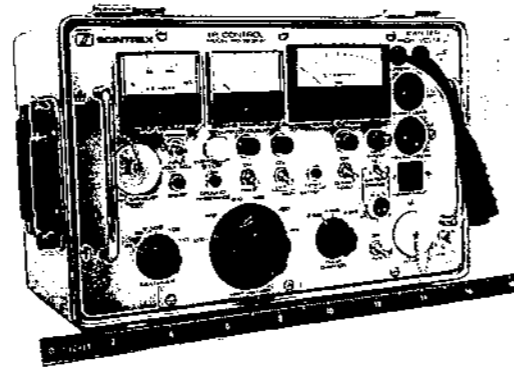
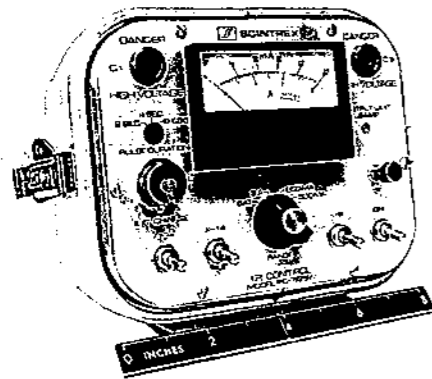

### 25W CONTROL UNIT

The 25 w transmitter is a recently developed light-weight battery powered transmitter. Because of its solid state design, the unit requires little maintenance. It employs sealed rechargeable lead acid batteries. Recharging can take place overnight (required time is 10 hours), from a d.c. source of two car batteries (12 V), or from the 110 V a.c. mains. The pulse duration of 2, 4 or 8 sec. can be selected.

#### SPECIFICATIONS:

<b>Output voltage</b>	in 5 steps between 40 and 200 V
<b>Max. output current</b>	0.5 amps
<b>Dimensions</b>	7"x7"x9"
<b>Weight</b>	11 lbs., including batteries
<b>Batteries</b>	2 sealed lead acid
<b>Battery life</b>	approx. 2 days approx. 200 recharges
<b>Charging power</b>	20 - 30 V (d.c.) or 115/230 V, 50/400 cps. with separate chargers.

### 2.5 KW CONTROL UNIT

The source of electric current is a 2.5 kw motor generator, whose armature voltage is regulated by a feed-back circuit providing a variable field voltage. The operating cycle consists of a 2 sec. pulse, 2 sec. off, 2 sec. reversed pulse, 2 sec. off. It is possible to change the intervals to 4 or 8 secs. The major system functions are performed by removable circuit boards, which make maintenance and control very easy. The dummy load is mounted in the control unit cover. The drive motor is a four cycle lightweight 8 hp. engine.

#### SPECIFICATIONS:

<b>Control Unit:</b>	
<b>Max. output voltage</b>	1500 V (d.c.)
<b>Max. output current</b>	10 amps
<b>Dimensions</b>	11"x18"x12"
<b>Weight</b>	65 lbs.
<b>Motor Generator Set:</b>	
<b>Maximum output power</b>	2.5 kw (single phase)
<b>Output voltage</b>	110 V (a.c.), 400 cps
<b>Weight</b>	130 lbs.

### 10 KW CONTROL UNIT

The 10 kw motor generator set provides single phase, regulated voltage for operating the dummy load, the high voltage circuit and the power supply. It is driven by an air-cooled Volkswagen industrial engine. Basically, the construction is similar to the 2.5 kw control unit, and also has 3 possible pulse durations (2, 4 or 8 secs.). Because of its larger size and weight, the dummy load is packaged separately.

#### SPECIFICATIONS:

<b>Control Unit:</b>	
<b>Max. output voltage</b>	5,000 V (d.c.)
<b>Max. output current</b>	20 amps
<b>Dimensions</b>	18 1/2"x27"x27"
<b>Weight</b>	170 lbs.
<b>Motor Generator Set:</b>	
<b>Max. output power</b>	10 kw (single phase)
<b>Output voltage</b>	208 V (a.c.), 400 cps
<b>Weight</b>	500 lbs.
<b>Dummy Load:</b>	
<b>Dimensions</b>	10"x10"x20"
<b>Weight</b>	75 lbs.
<b>Max. Power Dissipation</b>	10 kw

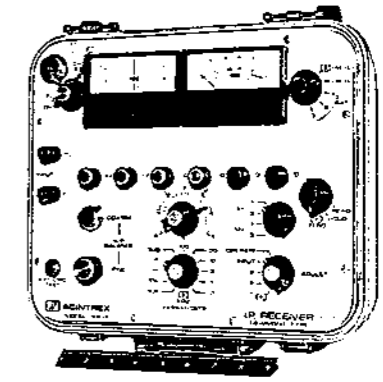

### IPR-7 NEWMONT TYPE RECEIVER

This type of I.P. receiver determines the chargeability from the area under the decay curve, which is integrated for 0.65 sec. (in case of 2 sec. pulse). The delay after the transmitter cut-off is 0.45 sec., which, under most conditions, eliminates the influence of electromagnetic transient effects. Besides the chargeability, which is read directly on a scale, it is possible to measure the "complement" on the decay curve and thus obtain a sensitive curve shape factor. In this fashion it is possible to learn more about the nature of the sources of anomalous apparent chargeability. As the signal to noise ratio increases approximately as the square root of the number of readings taken, effective filtering is achieved by automatic summing of a large number of readings. The next 0.65 sec. after integration are used for self-potential compensation, which is performed automatically by a memory circuit. This receiver is triggered by the primary current pulse and cannot be falsely triggered by a short duration electrical impulse.

#### SPECIFICATIONS:

<b>Primary voltage range</b>	0.0003 — 30 V
<b>Accuracy</b>	±3%
<b>Input impedance</b>	300 kilohms
<b>Chargeability:</b>	
<b>reading range</b>	0 — 100 and 0 — 300 msec.
<b>accuracy</b>	± 5%
<b>Curve factor:</b>	
<b>reading range</b>	0 — 100 and 0 — 300 msec.
<b>accuracy</b>	± 5%
<b>SP and VLF noise compensation</b>	
<b>Manual</b>	± 1.5 V
<b>Automatic</b>	depending on primary voltage range; up to ± 10 V total on 30 V range
<b>Power supply</b>	
	rechargeable nickel cadmium batteries; rated life 45 hours per charge
<b>Temperature range</b>	-20°F to 130°F
<b>Dimensions</b>	14"x11"x6 1/2"
<b>Weight</b>	13 1/2 lbs., including batteries



# Induced polarisation method

By Dr. HAROLD O. SEIGEL  
President, Scintrex Limited

REPRINTED FROM THE **MINING**  
OCTOBER 1970 ISSUE OF... **IN CANADA**

for  
 **SCINTREX**

The induced polarization method is based on the electrochemical phenomenon of Overvoltage, that is, on the establishment and detection of double layers of electrical charge at the interface between ionic and electronic conducting material when an electrical current is caused to pass across the interface.

In practice, two different field techniques (Time Domain and Frequency Domain) have been employed to execute surveys with this method. These techniques can yield essentially equivalent information but do not always do so. Instrumentation and field procedures using both techniques have evolved considerably over the past two decades. Much theoretical information for quantitative interpretation has been accumulated.

All naturally occurring sulphides of metallic lustre, some oxides and graphite, give marked induced polarization responses when present in sufficient volume, even when such materials occur in low concentrations and in the form of discrete, non-interconnected particles.

Induced Polarization is the only method presently available which has general application to the direct detection of disseminated sulphide deposits such as "porphyry type" or bedded copper deposits, and bedded lead-zinc deposits in carbonate rocks.

A number of case histories are documented where standard geoelectrical and other geophysical

methods failed to yield an indication of sulphide mineralization detectable by the induced polarization method.

Each rock and soil type exhibits appreciable induced polarization response, usually confined to a relatively low amplitude range, which is characteristic of the specific rock or soil. Certain clays and platy minerals including serpentine, sericite and chlorite, sometimes give rise to abnormally high responses. These effects are attributed largely to so-called "membrane" polarizations.

Despite a moderate amount of laboratory and field investigation, it is not feasible in general to differentiate between induced polarization responses due to Overvoltage and non-metallic sources, nor to differentiate between possible sources within each group.

Because of other variables, it is likewise difficult to uniquely equate a specific induced polarization response to a specific percentage of metallic content, although mean relationships have been established.

Through the measurement of secondary parameters, such as the transient decay curve form characteristics, one may obtain useful information relating to the average particle size of metallic responsive bodies or to the influence of electromagnetic transients on the I.P. measurements. The latter effect becomes prominent when surveys are made in areas with highly conducting surface materials, e.g. semi-arid regions.

# Induced polarisation method

By Dr. HAROLD O. SEIGEL  
President, Scintrex Limited

THE induced polarization (or I.P. as it is commonly known) method is, in application, the newest of our mining geophysical tools, having come into active use only in late 1948. Its roots extend somewhat farther back, however. Schlumberger (1920) reports having noted a relatively lengthy decay of the residual voltages in the vicinity of a sulphide body after the interruption of a primary D.C. current. Unfortunately, measurements in non-mineralized areas gave rise to rather similar residual polarization potentials, so he apparently abandoned his efforts.

In the late 1930's in the U.S.S.R. (Dakhnov, 1941) I.P. measurements were being made in petroleum well logging in an attempt to obtain information relating to the fluid permeability of the formations traversed by the well. Dakhnov mentions the possible application of the method to the exploration for sulphide mineralization, although it would appear that no such use was being made use thereof at that time. Unfortunately the volume of Dakhnov did not come to the attention of abstracters in North America until the spring of 1950.

Active development of the I.P. method as applied to mineral exploration in North America commenced with the writer's theoretical study in 1947 of the phenomenon of Overvoltage and his report (Seigel, 1948) on its possible application to geophysical prospecting. Laboratory and subsequent field investigation, sponsored by Newmont Mining Corporation in 1948 eventually led to the development of a working field technique and the recognition of polarization effects in all rocks (Seigel 1949).

Contemporaneously and independently D.A. Bleil (Bleil 1953) indicated the possibility of utilizing

I.P. in prospecting for magnetite and sulphide mineralization but apparently did not recognize the presence of non-metallic polarization effects in rocks.

Until 1950 all I.P. measurements were of the "time-domain" type (see below). In 1950, as the result of some laboratory measurements, L.S. Collett and the writer suggested the method of measuring I.P. effects using sinusoidal current forms of different frequencies. J.R. Wait expanded greatly on the possibilities of this approach and successful field tests were carried out in that year. The work of the Newmont group is summarized in a monograph (Wait 1959).

Since 1950 several groups have been active in the development of the I.P. method by means of theoretical laboratory model and field studies. Prominent among these groups has been that at the Massachusetts Institute of Technology (Hall of 1957) (Madden 1957) (Marshall 1959).

Within the literal meaning of the term, polarization is a separation of charge to form an effective dipolar distribution within a medium. Induced polarization is, therefore, a separation of charge which is due to an applied electric field. It may also include phenomena which cause voltage distributions similar to those due to true polarization effects.

For practical purposes, only polarization effects with time constants of build up and decay longer than a few milliseconds are of importance. This usually excludes such phenomena as dielectric polarization and others which are encompassed by the normal electromagnetic equations.

In order to measure I.P. effects in a volume of rock one passes current through the volume by means of two contact points or electrodes and

measures existing voltages across two other contact points.

Theoretically, any time varying current form can be used, but in practice only two such forms are employed. In the first technique a steady current is passed for a period of from one second to several tens of seconds and then abruptly interrupted.

The polarization voltages built up during the passage of the current will decay slowly after the interception of the current and will be visible for at least several seconds after the interception. This is termed the "Time Domain" method.

The "Frequency Domain" method entails the passage of sine wave current forms of two or more low, but well separated, frequencies, e.g. 0.1 and 2.5 c.p.s., or 0.5 c.p.s. and 10 c.p.s.

Since polarization effects take an appreciable time to build up, it can be seen that they will be larger at the lower frequency than at the higher, so that apparent resistivities or transfer impedances between the current and measuring circuits will be larger at the lower frequency. The change of measured resistivities with frequency is, therefore, an indication of polarization effects.

Further discussion of the precise quantities measured in the Time and Frequency Domain methods will be resumed after a presentation of some of the polarization phenomena involved.

When a metal electrode is immersed in a solution of ions of a certain concentration and valence, a potential difference is established between the metal and the solution sides of the interface. This difference in potential is an explicit function of the ion concentration and valence, etc.

When an external voltage is applied across the interface a current is caused to flow and the potential drop across the interface changes from its initial

value. If the electrode is a cathode it becomes more negative with respect to the solution, whereas if it is an anode, it becomes more positive with respect to the solution.

The change in interface voltage is called the "Overvoltage" or "Polarization Potential" of the electrode. If the electrode is a cathode, we speak of "Hydrogen Overvoltage" and, if an anode, of "Oxygen Overvoltage".

These Overvoltages are due to an accumulation of ions on the electrolyte side of the interface, waiting to be discharged. The charge of these ions will be balanced by an equal opposite charge due to electrons or protons on the electrode side of the interface.

For small current densities the Overvoltage is proportional to the current density, i.e. is a linear phenomenon. The variation of Overvoltage with several other factors is presented in the writer's Doctoral Thesis. (Seigel, 1949). The time constant of build up and decay is of the order of several tenths of seconds.

Overvoltage is, therefore, established whenever current is caused to flow across an interface between ionic and electronic conduction. In normal rocks the current which flows under the action of an impressed E.M.F. does so by virtue of ionic conduction in the electrolyte in the capillaries of the rock.

There are, however, certain rock forming minerals which have a measure of electronic conduction, and these include almost all the metallic sulphides (except sphalerite), graphite, some coals, some oxides such as magnetite, and pyrolusite, native metals and some arsenides and other minerals with a metallic lustre.

When these are present in a rock subjected to an impressed E.M.F., current will be caused to flow across capillary - mineral interfaces and

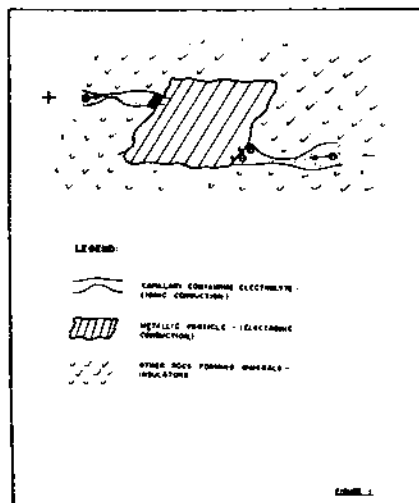

Induced Polarization Response of a Metallic Conducting Particle in a Rock.

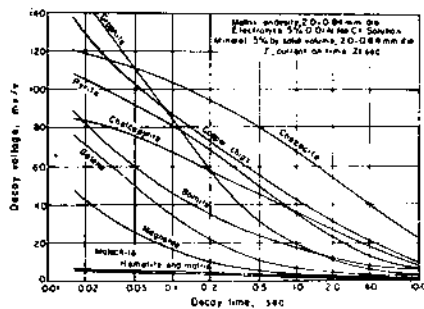

Decay Curves for Metallic and Non-metallic Minerals (after Wait, 1959).

hydrogen and oxygen Overvoltages will be established. Figure 1 is a simplified representation of what happens to an electronic conducting particle in a rock under the influence of current flow.

Despite attempts by various workers to investigate the source of non-metallic I.P. in rocks, an adequate explanation of all observed effects is still lacking. A number of possible contributory agents have been established. Vacquier (Vacquier et al, 1957) has carefully examined strong polarization effects due to certain types of clay minerals.

These effects he believed to be related to electrodiffusion of the clay particles. This is only one type of phenomenon which can cause "ion-sorting" or "membrane effects".

For example, a cation selective membrane zone may exist in which the mobility of the cation is increased relative to that of the anion, causing ionic concentration gradients and, therefore, polarization effects (see also Marshall, 1959). Much work remains to be done to determine the various agencies, other than clay particles, which can cause such membrane effects.

Time Domain Method: Figure 2 shows the typical transient I.P. voltage decay forms for various rock forming materials in a laboratory testing apparatus. See also Scott (1969). A primary current time of the order of 21 seconds was employed on these tests.

It will be noted that the voltages are plotted against the logarithm of the decay time and are approximate linear functions of the log t for reasonable lengths of time (t). The amplitude of the transient voltages has been normalized with respect to the steady state voltage existing immediately before the interception of the primary current.

In order to indicate the magnitude of the I.P. effects one may measure one or more characteristics of the transient decay curve and relate it back to the amplitude of the measured

primary steady state voltage prior to the interception of the primary current.

It may be shown that the ratio is  $V_s/V_p$ , i.e. peak polarization voltage to the primary voltage just before interception is a physical property of the medium, which has been called the "Chargeability" of the medium.

Since it has been demonstrated that most I.P. decay voltages are similar in form but differ in amplitude (for the same charging time) one can take the average of several transient voltages at different times, or indeed use the time integral of the transient voltages as a diagnostic criterion. The advantage of averaging or integrating lies in the suppression of earth noises and of electromagnetic coupling effects.

The chargeability is often designated by the letter "M". If the time integral is used the units of M will be in millivolt seconds/volt or milliseconds. If one or more transient voltage values are measured and normalized, M will be dimensionless.

For homogeneous, isotropic material, the value of M is independent of the shape or size of the volume tested and of the location of the electrodes on it. It is a true physical property. For a given medium it is dependent on the current charging time and on the precise parameter of the decay curve measured. There are also subsidiary variations with temperatures and electrolyte content, etc.

Frequency Variation Method: Figure 3 shows typical curves of the variation of normalized resistivities with frequency for various sulphide, graphite and non-metallic rock minerals in artificial mixtures. Both the fact of the variation of apparent resistivity with frequency and the presence of phase angle lags may be used to indicate the presence of I.P. effects, although generally only the first is so employed.

Since the I.P. phenomena may be shown to be linear, within the usual range of voltages and currents, there is

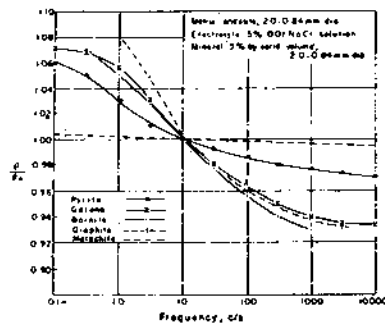

Resistivity-frequency Characteristics of Metallic and Non-metallic Minerals (after Wait, 1959).

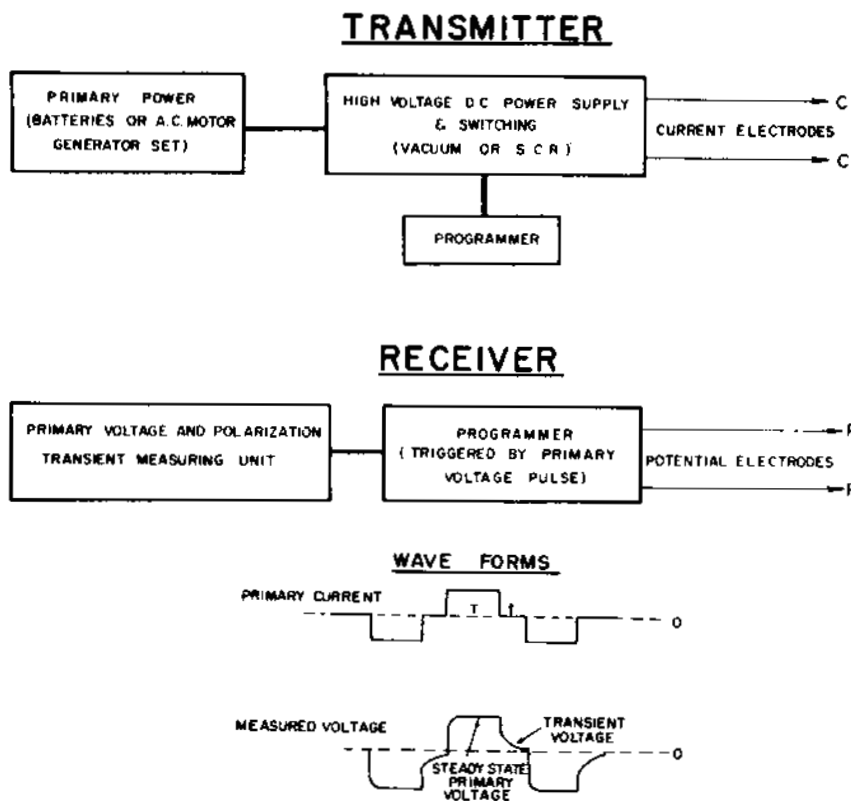

Time Domain Apparatus, Block Diagram and Wave Forms.

a direct relationship between the transient curve form and the variation of apparent resistivity with frequency. To arrive at a dimensionless parameter equivalent to the chargeability, one would have to normalize the apparent resistivity, by dividing by the resistivity at one particular frequency. The factor used is called the "Percent Frequency Effect" or P.F.E. and is defined as  $(R_1 - R_2 / R_1) \times 100$  where  $R_1$  and  $R_2$  are the apparent resistivities at the lower and higher frequencies used (Marshall, 1959).

A second parameter is sometimes employed which is really a mixture of physical properties. It is called the Metal Factor (M.F.) and is proportional to P.F.E./ $R_2$  or to  $M/R$ . As such, it serves to emphasize I.P. effects which occur in obviously conductive environments, i.e. concentrated sulphide deposits or sulphides and graphite in shear zones.

Since it is not a dimensionless factor nor a true single physical property, it is subject to variation related to the changes of shape and resistivity of the medium under investigation, rather than simply to variations in polarization characteristics.

In my opinion, the metal factor has some merit in emphasizing I.P. anomalies due to concentrated metallic bodies, but should not be used as a primary indicator of abnormal I.P. conditions.

Figure 4 shows a block diagram of apparatus commonly used in field operations with the time-domain method and the primary current and resultant voltage wave forms. The transient voltage amplitudes are considerably exaggerated to be visible.

Power sources up to 30 K.V.A., 5000 volts and 20 amperes have been employed where extreme penetration is desired in low resistivity areas. The current-on time  $T$  ranges from one

second to as much as 30 seconds, and the current-off time  $t$  may be as much as 10 seconds. It is not strictly necessary to employ a cyclic current wave form, but considerable advantages in signal-to-noise ratio are achieved thereby.

Most of the receivers now employed are remote triggering, i.e. they are internally programmed, triggered by the primary voltage pulse and do not require a cable interconnection to the cycle timer on the power control unit. Figure 5a shows a typical time-domain remote-triggered receiver (Scintrex MK VII, Newmont-Type). This particular receiver has several interesting features.

For one, there is a memory circuit which provides an automatic self potential adjustment at the tail end of each cycle. For another, it has the ability to integrate the area either below the transient curve (standard M measurement) or above the transient curve (denoted as the L measurement) over a specific time interval. The ratio of these quantities gives a direct

FIGURE 4

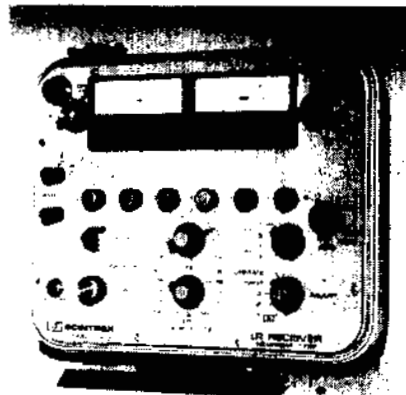

Typical Modern Time Domain I.P. Receiver (Scintrex Mk. VII)

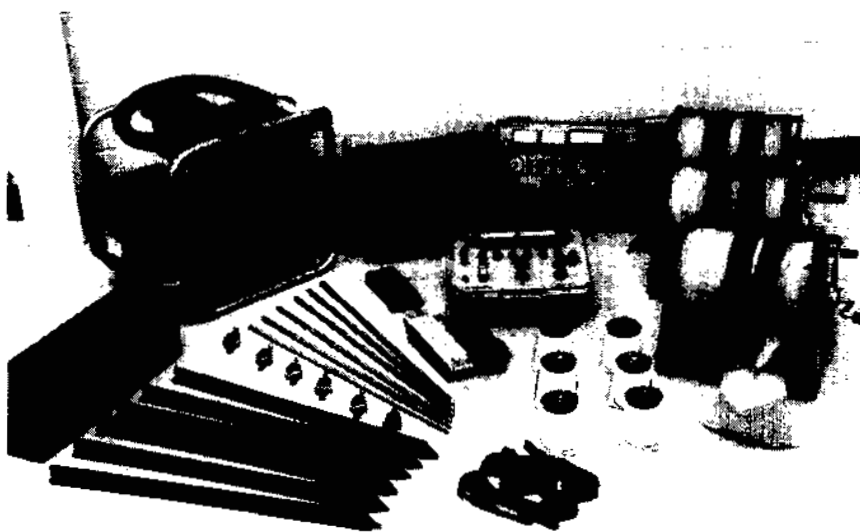

Typical Modern Time Domain I.P. Unit (Scintrex Mk VII)

FIGURE 5b

Array	Domain Employed	Advantages	Disadvantages
Wenner	Time	For local vertical profiling.	Poor depth penetration. Requires four linemen.
Three Electrode (or Pole-Dipole)	Time and Frequency	Three linemen. Universal coupling. Good depth penetration.	Susceptible to surface masking effects.
Dipole-Dipole	Frequency	Good resolution. Universal coupling.	Complex curve forms. Low order signals. Susceptible to surface masking effects.
Gradient	Time	Minimum masking. Two linemen only. Excellent depth penetration. Excellent resolution. Can use multiple receivers for speed.	Couples best with steeply dipping bodies. Low order signals.

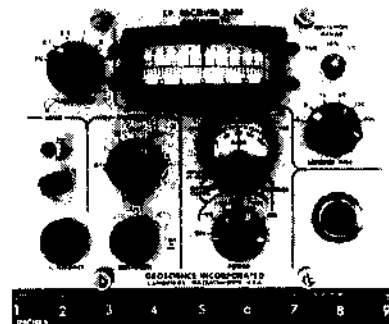

Typical Modern Frequency Domain Receiver (Geoscience).

It measures both the primary voltage and the change of primary voltage with change in operating frequency, the latter to an accuracy of about  $\pm 0.3\%$  when the former exceeds 100 microvolts. It has the added feature of a phase lock voltmeter which assists in making measurements under low signal-to-noise conditions.

Common field electrode arrays are shown in Figure 8. The electrodes marked C are current electrodes and those marked P are potential or measuring electrodes. Each of the electrode arrays has its own advantages and disadvantages in respect of depth of penetration, labour requirements for moving, susceptibility to earth noise, electromagnetic earth transients and interline coupling. The following table summarizes the features of these arrays.

For each array (except the gradient array) the basic electrode spacing "a" is selected to give adequate penetration down to the desired depth of exploration. For the pole-dipole and double dipole it is customary to obtain several profiles for different values of "a" or for integral values of n from 1 to as much as 4.

For the symmetric arrays (Wenner and Dipole-Dipole) the measured values are plotted against the midpoint of the array. When using the Three Electrode Array (time-domain) the station position is taken to be the midpoint of the moving current and the nearest potential electrode. When using the Pole-Dipole (frequency domain) the station position is taken as the midpoint between the moving current electrode and the midpoint of the two potential electrodes.

With the Gradient array it is the midpoint of the two potential electrodes. For the Three Electrode array and Pole-Dipole these station locations are not unique and represent conventions only.

I.P. data may be plotted in profile form or contoured, although it should be noted that somewhat different results will be obtained with different line orientations so that contouring is

measure of the decay curve form, which may be of diagnostic value (see below). In areas of low electric earth noise useful measurements may be made with primary voltages as low as 300 microvolts. Figure 5b shows a complete typical modern time domain induced polarization unit (Scintrex MkVII) of which the Newmont-type receiver above is a part.

Figure 6 shows a block diagram of a typical frequency domain field apparatus and voltage wave form. Since the primary current and earth voltages are usually measured by

separate devices and their ratio employed to obtain the apparent earth resistivity and its variation with frequency, it is common practice to adjust the current to a standard value and maintain it there to the required accuracy.

The primary wave form is usually a commutated D.C. Commonly, up to 6 frequencies are available in the range of 0.05 to 10 c.p.s. Figure 7 shows a typical modern frequency domain measuring unit. This unit has a high degree of power line frequency (50 c.p.s. to 60 c.p.s.) rejection.

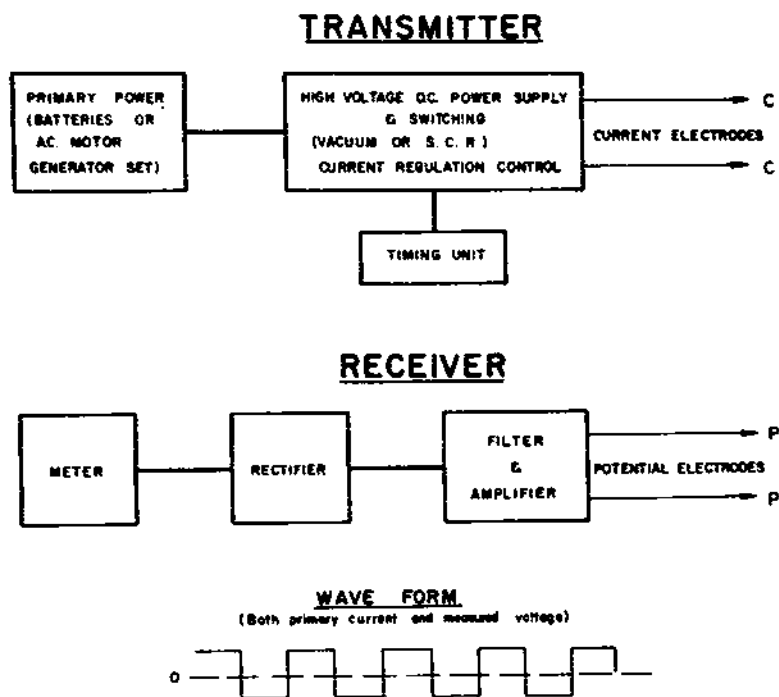
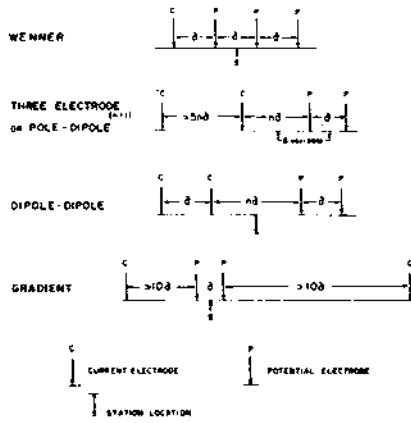
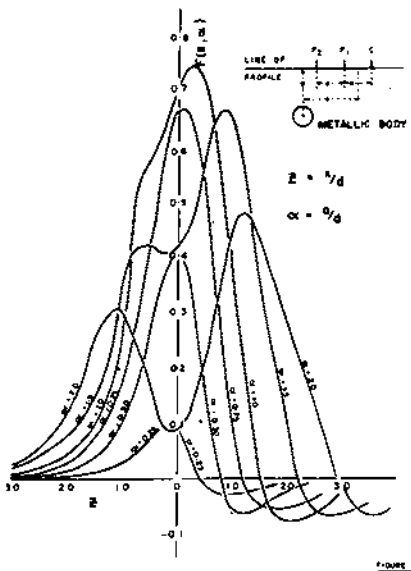

FIGURE 6.

Frequency Domain Apparatus, Block Diagram and Wave Forms.



Common Field Electrode Arrays.



Theoretical Response of a Sphere, Three Electrode Array.

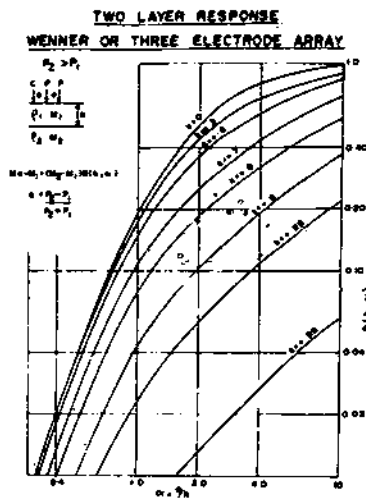

Theoretical Response of Two Layer Earth, Wenner or Three Electrode Array.

not strictly justified. Profile interpretation is superior, particularly for shallow, confined bodies, because multiple peaked curves may arise from such bodies using certain electrode arrays, and the plotted peaks may give an erroneous impression of the location of the polarizable body.

To obtain the variation of physical properties with depth, expanding arrays may be used with any of the electrode systems, keeping the spread centre fixed and simply changing the relative spacing "a". This is of particular value where it is known or expected that vertical variations of physical properties will be much greater than lateral variations.

As the spacing is increased the influence of the deeper regions becomes more significant, and the resultant resistivity and I.P. curves may often be interpreted to give the depth to discontinuities in physical properties and the physical properties themselves.

Common practice in presenting frequency domain results is to plot the measured data below the line at a depth equal to the distance of the station position (as defined above) from the midpoint of the potential dipole. When this is done for a variety of values of "n" a pseudo two-dimensional section, results which show, albeit in a markedly distorted fashion, the variation of physical properties with depth.

A mathematical representation of I.P. effects has been developed by the writer (Seigel, 1959), which relates the observed I.P. response of a heterogeneous medium to the distribution of resistivities and I.P. characteristics. To a first approximation it is equally applicable to any I.P. parameter measured in the time and frequency domains.

From this theory, one may predict the anomalous response to be

expected from a specific body with a given chargeability and resistivity contrast. For example, Figure 9 shows the form factor F plotted for the Three Electrode Array for a sphere for various values of  $\lambda$ , where  $\lambda$  is the ratio of the electrode spacing to the depth of the centre of the sphere. The sphere response is proportional to F times the chargeability contrast, times its volume and times a resistivity-ratio factor. A number of such theoretical curves, for the pole-dipole and gradient arrays, using spheres and ellipsoids as models, may be seen in the paper by Dieter (1969) et al.

Curves of this sort permit one to interpret anomalies due to localized bodies. It will be seen that for each array there is an optimum spacing for a body at a particular depth, and, therefore, there is some meaning to the term "depth of penetration", except for the gradient array.

When the dimensions of the polarizable medium are large in comparison with its depth below surface, as is often the case, particularly in investigation of porphyry copper type deposits, a two layer approximation is adequate. Theoretical curves based on this approximation (Figure 10) may be used to interpret the results of expanding Wenner or Three Electrode array depth determinations.

For more complex geometries, mathematical solutions in closed form are often lacking. For such cases one may resort to model studies (e.g. Figure 11 for buried dike.) or to computer calculated solutions.

The most productive use of the I.P. method to date has been in the exploration for deposits of metallically conducting minerals, where the amounts and degree of interconnection of these minerals are too low to give rise to an electromagnetically detectable body.

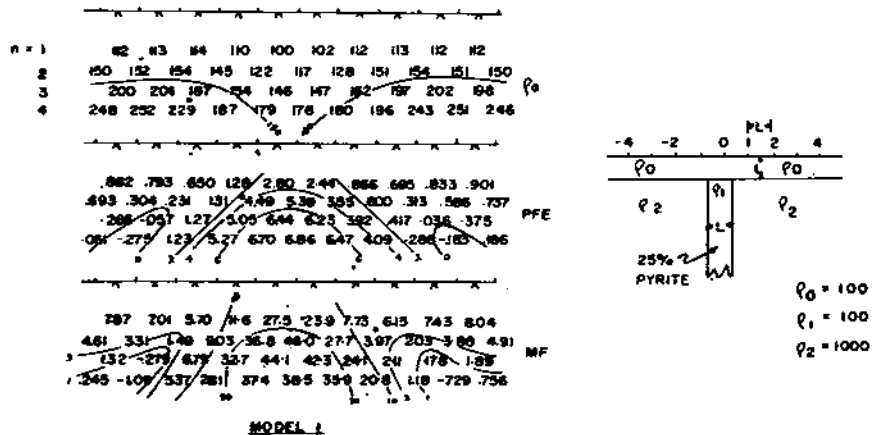

Model Response of a Dike, Dipole-Dipole Array (courtesy K. Vozoff).

FIGURE 11

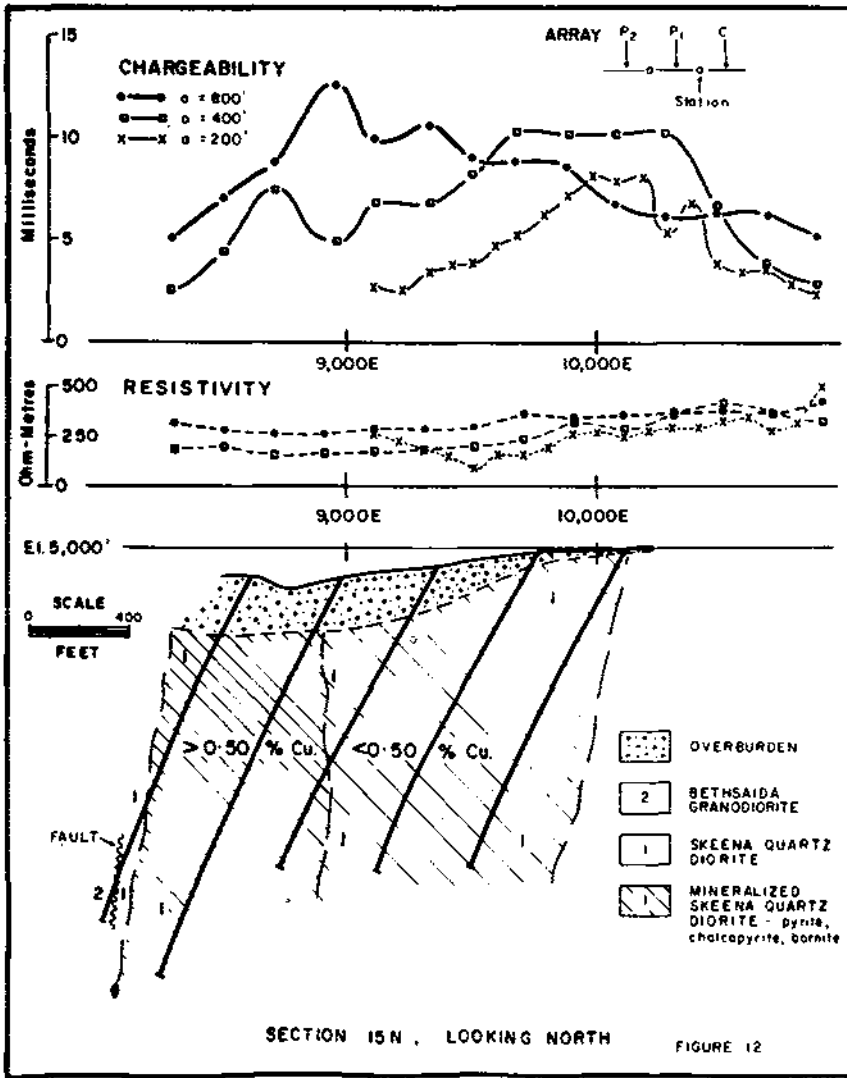

Geophysical and Drilling Results, Lornex Porphyry Copper Ore Body, British Columbia, Canada (courtesy Lornex Mining Corp. Ltd.)

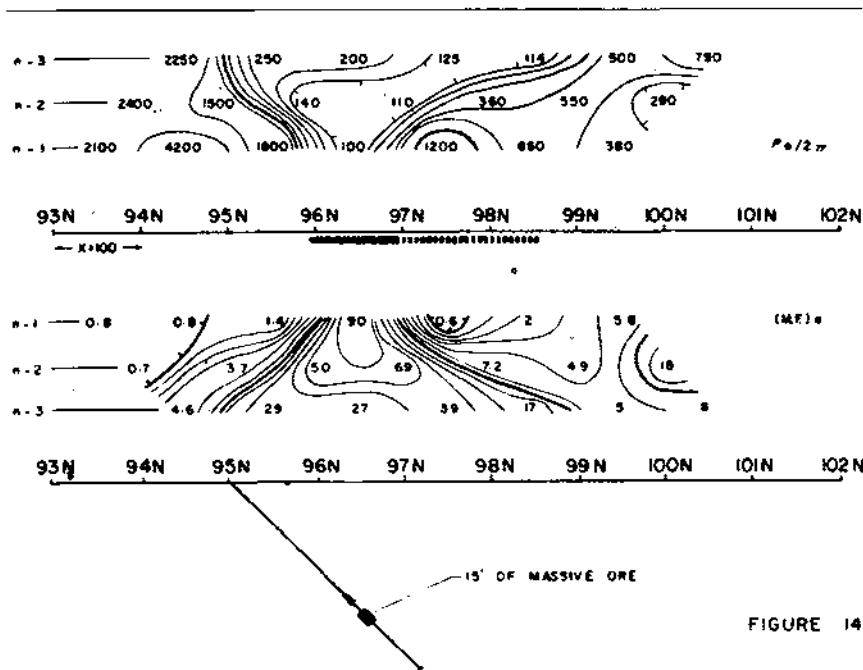

Geophysical and Drilling Results Lead-Zinc-Copper Ore Body, Heath Steele Mine, New Brunswick, Canada (courtesy P. Hallöf).

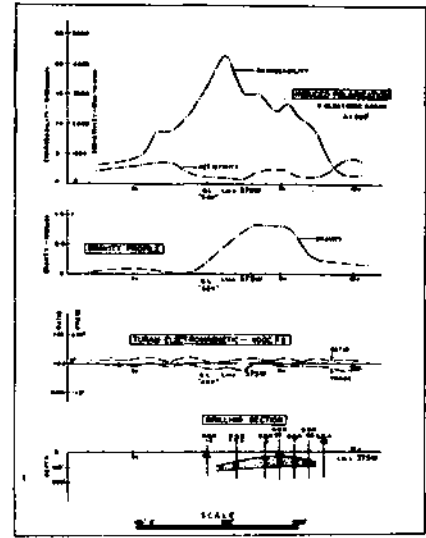

Geophysical and Drilling Results, Pyramid No. 1 Lead-Zinc Ore Body Pine Point Area, Northwest Territories, Canada (courtesy Pyramid Mines, Ltd.).

Where electromagnetic detection is feasible it is usually far more rapid and economical to apply electromagnetic induction methods to the problem. The I.P. method is the only geophysical tool available which is capable of direct detecting 1 percent or less by volume of metallic conducting sulphides.

It is best used, therefore, where there is a high ratio of economic minerals to total sulphide mineralization. Included in the proper I.P. range are such types of deposits as disseminated copper ores, in porphyry or bedded forms; lead-zinc deposits, particularly of the bedded type in carbonate rocks; gold and other deposits which have an association with disseminated metallic conductors. For many of these mineral occurrences the I.P. method is unique in providing detection.

Figure 12 shows time-domain discovery traverses over a typical newly discovered porphyry copper deposit in British Columbia. The lateral limits of the mineralization can be readily determined from the geophysical data, as well as the depth to the upper surface of the mineralization.

Figure 13 shows a discovery traverse over a major bedded body of sphalerite-galena-marcasite mineralization in carbonate rocks in the Pine Point area, Northwest Territories, Canada. For comparison purposes both gravity and Turam electromagnetic profiles on the same section are shown.

It is interesting to note that, despite an appreciable resistivity depression over the mineralization there is no significant Turam response at 400 c.p.s. The conductivity of the ore is, in fact, no higher than that of the surficial deposits in the general area, so that



electromagnetic and resistivity methods yield, in themselves, no useful information.

The gravity method, although yielding a positive response in this instance, does not provide a good reconnaissance tool in this area because of karst topography and other sources of changes in specific gravity.

One occasionally encounters a deposit of the "massive sulphide" type which is normally thought of as an electromagnetic type of target because of its high conducting sulphide content, but which, obviously because of the lack of large scale continuity of the conducting sulphides, does not respond to the electromagnetic techniques. Figure 14 shows an intersection of ore grade material of this type, in New Brunswick, Canada, where electromagnetic methods had yielded negative results.

In many types of ore deposits the bulk of the I.P. response is due to the accessory non-economic sulphides, usually pyrite and pyrrhotite, and the ore minerals themselves are in the minority. A true test of the sensitivity of the I.P. method is an example of a low grade disseminated deposit with no such accessory minerals. Figure 15 illustrates such a case, with an I.P. discovery section over the Gortdrum copper-silver-mercury deposit in Ireland. The ore minerals consist of chalcocite, bornite and chalcopyrite in a dolomitic limestone, and there is less than 2% average by volume of metallic conducting minerals.

Whereas the bulk of I.P. measurements in mineral exploration has, naturally, been made on surface, the technology of drill hole exploration has been well developed, particularly by the Newmont group (see Wagg, 1963). The time-domain method is suitable for drill hole applications since it permits a relatively close coupling of the current and potential lines in a small diameter bore hole.

The three electrode array has been extensively employed for logging purposes, with a variety of electrode spacings to give varying ranges of detection away from the hole. In this fashion the variation of electrical properties with distance from the hole may be determined. A second, "directional log" then gives information on the direction of any anomalous material indicated by the detection log.

Whereas the I.P. method is usually employed as a primary exploration tool it may play an auxiliary role as well, e.g. to distinguish between metallic and ionic conducting sources of other types of electrical anomalies, e.g. electromagnetic.

Figure 16 shows a typical conducting zone revealed by a ground

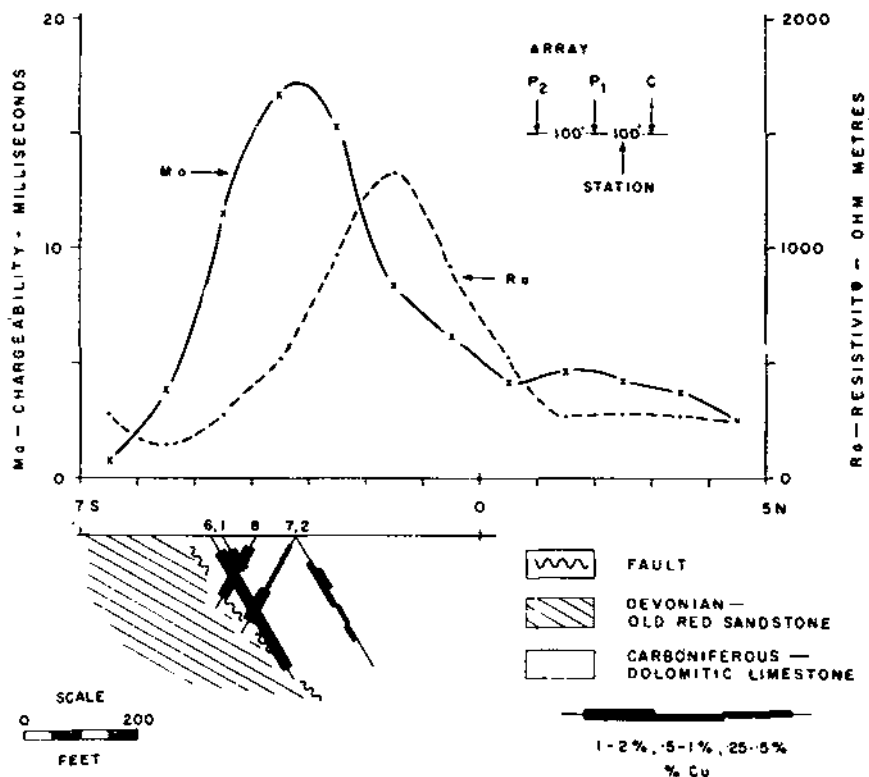

SECTION 200E, FACING WEST  
S ELECTRODE ARRAY -  $a=100'$

FIGURE 15

Geophysical and Drilling Results, Copper-Silver Ore Body, Gortdrum Mines, Ireland (courtesy Gortdrum Mines, Ltd.).

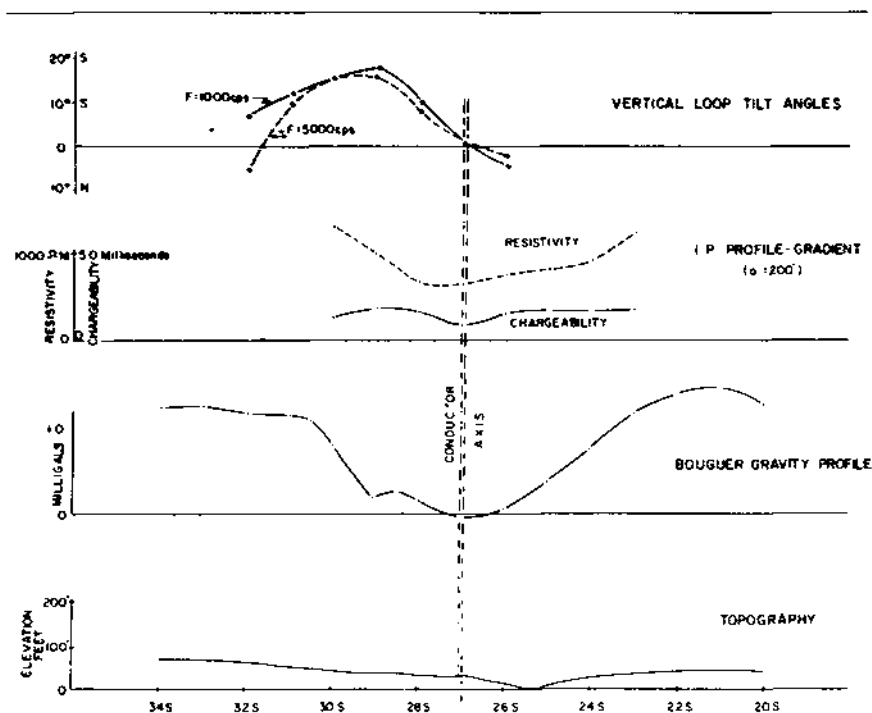

FIGURE 16

Geophysical Recognition of Overburden Trough, Northwest Quebec, Canada.

electromagnetic survey which was later proven, by drilling, to be due to overburden conduction in a bedrock trough. The I.P. response is in the low-normal range. The gravity profile, also shown, corroborates the presence of the bedrock depression.

Attempts have been made by a number of workers to employ the I.P. method in the field of groundwater exploration (e.g. Vacquier, 1957, Bodmer, 1968) but with no consistent success as yet. There are variations of chargeability from one type of non-consolidated sediment to another, but these fall, in general, within a relatively small range compared to the usual sulphide responses.

More investigation remains to be done in this area before a definitive conclusion can be reached. It is clear that more accurate measurements will have to be made in groundwater I.P. than in base metal I.P. investigations.

The I.P. method has a number of recognized limitations, some of a fundamental nature and others of a temporary nature reflecting the current state of the art. On a unit coverage basis the method is relatively expensive to apply, costing between \$200 and \$500 per line mile surveyed, in most instances. This cost has, however, been progressively reduced by advances in instrumentation resulting in decreased weight, increased

sensitivity and rejection of earth noise effects. Some degree of improvement is yet to be expected in this area.

The same geometric limitations apply as with the resistivity method employing the comparable array. As a rule, a body of up to 10 per cent disseminated metallic conductors cannot be detected at a distance from its nearest point much exceeding its mean diameter. This detectability may be somewhat improved by the use of secondary criteria, but such improvement is likely to be only marginal.

Since Overvoltage is essentially a surface phenomenon the I.P. response from a given volume percentage of metallic conductors generally increases as the individual particle size is decreased. From the usual simple I.P. measurements, therefore, one cannot reliably predict the percentage by volume of such conductors in a deposit as there may be a variation of particle size throughout the deposit.

Still less can one differentiate between metallic conductors (e.g. chalcopyrite, galena, pentlandite) of economic interest and those of non-economic interest (e.g. pyrite, pyrrhotite and graphite). In addition we cannot even reliably differentiate between metallic sources of I.P. responses. The latter may include certain types of clay and, in consoli-

dated rocks, such as platy alteration minerals as serpentine, talc and sericite.

Empirically it has been found that, on the average, 1% by volume of metallic sulphides will increase the chargeability by about 2 - 3 times, depending on the host rock type.

Figure 17 shows a section across each of two anomalous I.P. areas in the Pine Point area, Northwest Territories, Canada. Section A is a discovery traverse across an ore body containing one half million tons of 11.4 per cent combined Pb and Zn and coming within 40 ft. of the ground surface. Section B is a traverse across what proved, by drilling, to be a karst sink hole, filled in with a variety of unconsolidated material including boulders and clay.

Based upon the chargeability amplitudes and the relative resistivity depressions the second case would appear to be far more promising than the first. In such cases the gravimeter has sometime proven to be of value in resolving the two types of occurrence but there is the very real possibility of the coincidence of a sink hole and a lead-zinc deposit, which would give rise to an uncertain resulting gravity response.

Any normal transient (time-domain) polarization decay and equivalently any curve of variation of apparent resistivity with frequency may be simulated by means of a mixture of metallic conductors of a suitable particle size distribution.

It is, however, possible in an area of common geology, that the various possible sources of I.P. responses may have significantly different characteristic curves in each of these two domains. A more thorough analysis of these curves at significant points is, therefore, of value.

Modern receivers in both domains (Figures 5 and 7) have the ability to give curve form information as well as a single quantity related to an I.P. amplitude.

Komarov (1967) documents such an example over a copper nickel deposit in the U.S.S.R. where, effectively the sulphide responses have a longer time constant than the normal non-metallic polarization.

An important source influencing I.P. measurements is the electromagnetic response of the earth. For a given electrode array the electromagnetic effect is dependent upon the frequency times the conductivity and the square of the spacing. In the frequency domain this source becomes troublesome (communication from P.G. Hallof) when:

1. The electrode spacing is 500 ft. or over and  $n = 3$  or greater.
2. The highest frequency employed is 2.5 c.p.s. or greater.

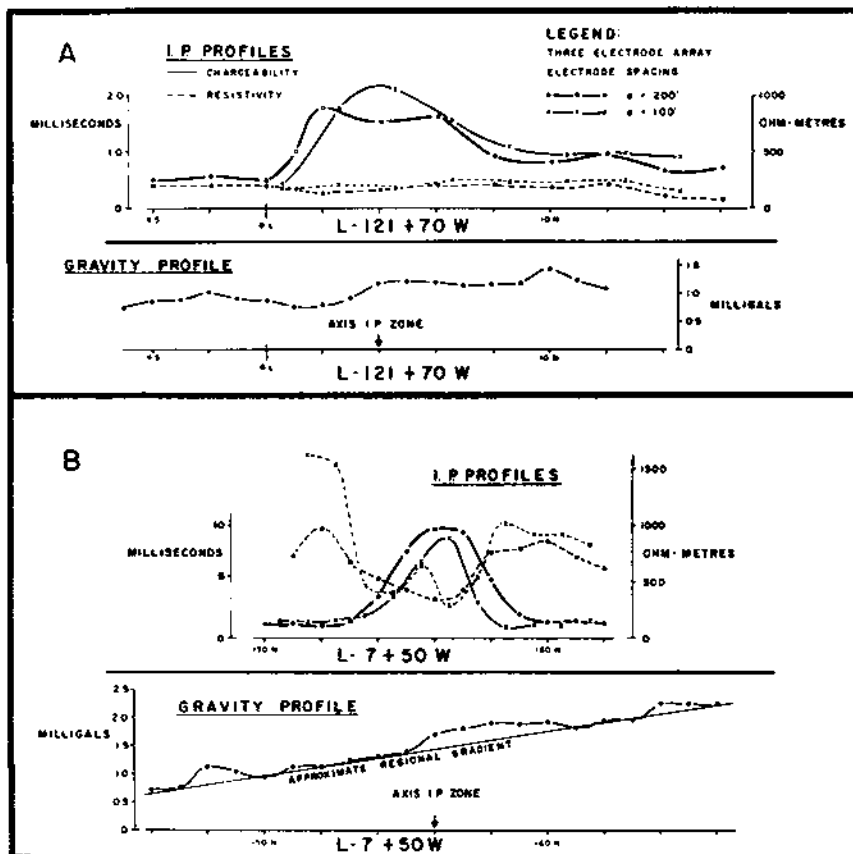

FIGURE 17

Possible Ambiguity of Induced Polarization Results, Pine Point Area, Northwest Territories, Canada.

3. The average earth resistivity is lower than about 25 ohm metres.

Electromagnetic effects are present in the time-domain measurements as well, of course, but are usually of lesser amplitude for the same array and earth conductivity, because the effective frequencies employed in the time domain are considerably lower (commonly 0.03 to 0.125 c.p.s.).

In the extreme, the electromagnetic response of a conducting earth may seriously interfere with useful I.P. measurements in either domain.

In the time domain I.P. measurements commonly only a single amplitude (at a specific time after current interruption) or an average amplitude over an interval of time after the current interruption is used to characterize the transient decay curve and act as a measure of the induced polarization characteristics of the medium in question.

It has been known since 1950 that useful secondary information is available in the shape of the transient decay curve associated with time domain induced polarization measurements. Equivalent remarks may be made in respect of frequency domain measurements where, instead of measuring the average slope of resistivity frequency over one decade of frequency, more information is obtained about the shape of this curve.

The type of information inherent in the curve shape relates primarily to two factors — (a) average metallic particle size associated with the source of an anomalous I.P. response, and (b) the presence of electromagnetic transients arising from highly conducting geologic units. For convenience we will restrict the following remarks to time domain measurements, although equivalent statements may be made in the frequency domain.

It has been established through laboratory measurements that (a) metallic conductors of large average particle size give rise to time domain decay curves of relatively long time constant, and (b) metallic conductors of small average particle size give rise to decay curves of relatively short time constant. For these reasons, if a shape factor as well as an amplitude factor of the decay curve can be established we may obtain information which is helpful in some of the following circumstances:

(1) very large or very small metallic particles — the response from these may distort the shape as well as the amplitude of the transient curve. Thus rather small amplitude anomalous metallic responses may be recognized in the presence of equal I.P. relief due only to non-metallic variations.

(2) two different types of anomalous

response materials, in the same survey area, but differing in average particle size and/or decay curve form — e.g. serpentine, graphitic particles of small average size and coarse grained metallic sulphides.

One additional and rather common circumstance is the presence of (ionically) highly conductive overburden or consolidated rock units (e.g. saline overburden or shales). These units can give rise to electromagnetic transients of sufficiently long time constant to affect the usual I.P. amplitude measurement.

The shape of the E.M. transient is, in practice, markedly different from that of the usual I.P. transient, having a much shorter time constant than the latter. In addition, the polarity of the E.M. transient is often reversed to that of the I.P. transient. Curve shape measurements can provide a clear indication of the presence of significant E.M. interference and even a semi-quantitative estimate of the latter, enough to allow a correction factor to be applied.

Equipment of the type illustrated in Figures 4 and 5 (e.g. Scintrex MK VII System) permit appropriate transient curve shape information to be obtained. Common to all the transmitters in this system is the ability to pass a repetitive, interrupted square wave pattern current

into the ground, as shown on Figure 4. The current-on time may be 2, 4, or 8 seconds and the current-off time may be likewise selected. Measurements of I.P. transient curve characteristics are made during the current-off time.

Figure 18 shows the quantities measured by the Newmont-type receiver. In these receivers one sets the gain of certain amplifiers common to both the primary voltage  $V_p$  and transient voltage  $V_t$  measurements so that these voltages are essentially normalized.

The usual amplitude measurement performed by these receivers consists of an integration of the area under the transient curve over a specified interval after the interruption of the primary current and is designated by the letter M — the "chargeability" namely, 0.45 seconds to 1.1 seconds.

The 0.45 second delay time allows most E.M. transients, switching transients and interline coupling effects to disappear prior to the making of the measurement. Different measuring intervals may be employed under specific conditions.

In addition to M, the Newmont-type MK VII receiver is equipped to measure a quantity "L" which is defined as the time integral of the area over the transient curve, for a specified time interval, taking as reference voltage the

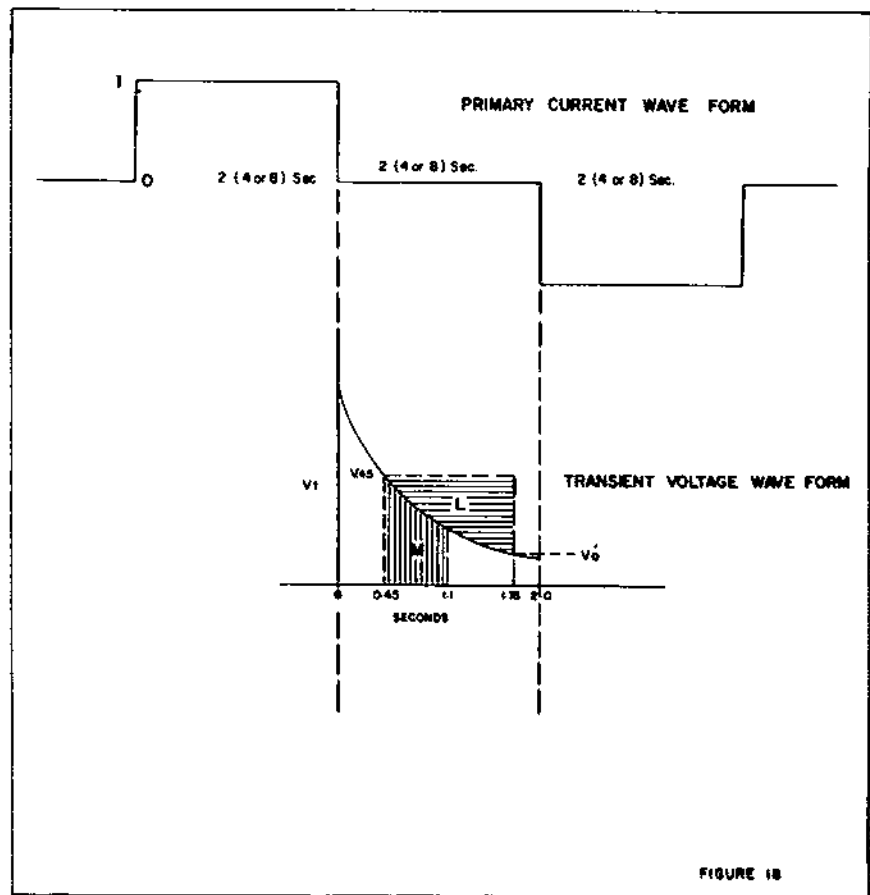

FIGURE 18

Operation of Scintrex Mk VII (Newmont-type) I.P. System.

transient voltage value at the beginning of the time interval. In practice, the interval selected is 0.45 seconds to 1.75 seconds, as shown on Figure 18, although different intervals may be employed under certain conditions.

The ratio of  $L/M$  is taken as a sensitive indication of transient curve shape. It has been well established, by many tens of thousands of I.P. measurements with these systems in many parts of the world, that the  $L/M$  measurements in non-metallically-mineralized areas, for a given current wave form, are constant within better than 20%.

Significant departures from these ratios usually imply an abnormal condition — either an anomalous metallic polarization response, electromagnetic or interline coupling.

Figure 19 shows a range of transient curves and their possible cause. For each case the "normal" transient curve is also shown. These cases illustrate the sensitivity of the  $L/M$  ratio to the transient time constant. A significant increase in  $L/M$  implies an abnormally short time constant, (Case A) reflecting either positive E.M. effects or small particle size. This should, in either case, normally be accompanied by an increase in apparent chargeability  $M$ .

A modest increase in  $L/M$  ratio, reflecting an increase in time constant (Case B) may reflect either the presence of large particle size metallic conductors, in which event an increase in  $M$  may or may not be appreciably reduced.

Cases C and D show the effect of reversed polarity E.M. transients of increasing amplitude. In Case C there is a short term  $V_t$  reversal and, although  $M$  is only slightly reduced,  $L/M$  is considerably reduced. In Case D, which is considerably more extreme,  $V_t$  is still rising at 0.45 seconds, so that  $L$  and thus  $L/M$  are, in fact, negative.  $M$  is considerably reduced from its normal value in this case, but a warning to this effect is clearly indicated by the  $L$  measurement.

A quantitative estimate of the E.M. transient response and, therefore, correction for it, may be obtained by one of a number of means. One may, for example, vary the current-on time, e.g. from 2 seconds to 8 seconds. The E.M. transient, being of relatively short time constant, will not change. The I.P. response will change by an amount which is fairly predictable, assuming a normal decay form. We thus obtain two equations in two unknowns from which the true I.P. response may be derived.

Curve shape measurements may be made in other ways as well, for example, by actually recording the complete transient decay curve. Whereas theoretically useful, such

measurements have proven unwieldy from a weight and time standpoint. To obtain clean decay curves requires a high signal/noise ratio and thus high powers.

In the frequency domain the equivalent curve form information would be obtained through the use of three or more properly selected operating frequencies.

There is a continuing rivalry between protagonists of time-domain and frequency domain measurements. All that is clear is that neither method is superior in all respects to the other. The same phenomenon is being measured in different ways often with different arrays and the results are presented different formats (pseudo-sections in the frequency domain versus profiles in or contour plans in the time domain).

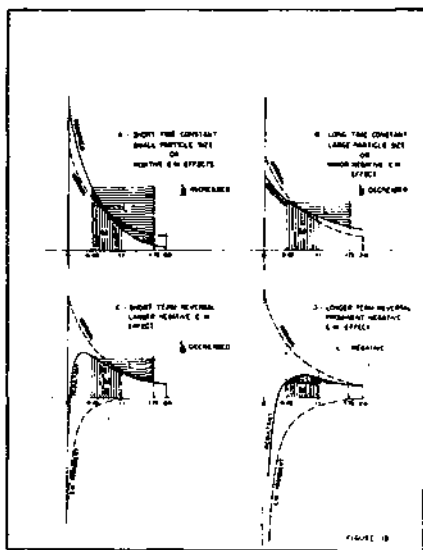

Significance of Curve Shape ( $L/M$ ) Information.

The "Metal Factor", which is a mixture of physical properties, is commonly presented with frequency domain measurements only. These differences are largely superficial and are based on separate historical developments and subjective preferences.

There is a direct mathematical transformation between I.P. measurements in the two domains. Theoretically, at least, the same information can be obtained in either domain. Practically, however, there are certain differences.

The time domain measurements are absolute, i.e. are measured in the absence of the steady state voltage and are disturbed only by earth noises as a background. The amplitude of these measurements is usually less than 1% of the steady state voltage, but even so they can usually be made to an accuracy of better than 10 per cent even in unmineralized rocks.

The limit of useful sensitivity is related only to the regional uniformity of the background I.P. response. In the frequency domain the I.P. response is measured as a difference in transfer impedances. This difference can be measured with an accuracy of only 0.3% with extremely stable equipment. Since the non-metallic background P.F.E. over the interval of 0.1 to 2.5 c.p.s. is usually less than 1%, the probable error of these measurements may be 30% or more.

For this reason it is seen that it is feasible to obtain greater sensitivity of measurement in the time domain. This increased sensitivity is of value in areas of low "geologic" and electrical noise. By "geologic noise" is meant the range of variation of I.P. parameters within the normal rock types of the area. The application of I.P. to groundwater prospecting may have to develop through the time domain avenue because of the sensitivity requirements.

The frequency domain equipment requires somewhat less primary power than the time domain equipment because the former measurements in an A.C. one with the ability to use tuned filters and amplifiers as well as devices as phase-lock detectors. This advantage is not so marked as it once was, as current time-domain equipment, with its self adjusting earth voltage balance and ability to sum any desired number of integrations, provides a high degree of noise rejection.

Under truly random noise conditions the summation of  $n$  integrations provides the usual  $1/\sqrt{n}$  reduction in statistical noise and is a powerful non-subjective means of noise suppression. The suppression of A.C. power line noise is much better with the time domain (integrating type) measurements than with frequency domain measurements.

Reference has already been made above to the relative effects of the electromagnetic response of the earth in both methods. Similar remarks apply to capacitative and inductive coupling effects between current and potential cables, although such effects can be largely avoided in any event by careful positioning of the cables, except possibly in drill hole surveying. So far, only in the time domain may useful drill hole measurements be made with both current and potential electrodes lying side by side in a small diameter bore hole.

An individual geologist or geophysicist may have had his first acquaintance with or instruction in the I.P. method using either the time domain or frequency domain. He becomes familiar with the arrays used and with the method of presentation of data employed. Thereafter, he tends to

resist switching to the other domain in the belief that not only will he have to deal with different geophysical equipment and electrode arrays but also with different quantities, presented in quite a different fashion. This is erroneous.

So far as arrays are concerned the time domain uses them all – dipole-dipole, pole-dipole (three electrode) Wenner and gradient (Schlumberger). The frequency domain commonly uses only the first two and is restricted from using the latter two because of interline coupling effects.

Of the quantities measured in both domains the resistivity is, of course, the same, making due allowance for units. The time domain "Chargeability" is, normally very nearly proportional to the "Percent Frequency Effect" or "P.F.E.". The so-called "Metal Factor" is the ratio of P.F.E./Resistivity, and would, therefore, be equivalent to the ratio of Chargeability/Resistivity.

The time domain data presentation

is commonly in the form of profiles and contour plans.

The frequency domain presentation is commonly in the form of "pseudo-sections" showing the different spacing results displaced progressively downwards with increased electrode spacing. Either type of data may be presented in either form of course, to suit the tastes and experience of the individual geologist or geophysicist.

The Gradient array is very useful in obtaining bedrock penetration where the bedrock is highly resistive compared to the overlying overburden. In such cases using the pole-dipole or dipole-dipole array very little current actually penetrates the bedrock and the I.P. characteristics observed are those of the overburden only. As was mentioned above, only time domain measurements may be carried out using this array.

There is a special practical advantage to the time domain measurements in areas where it is very difficult to make good ground contact. In such areas the

problem of keeping the primary current rigidly constant, necessary for the frequency domain measurements, becomes severe.

In the time domain, if the primary current varies by as much as 10% during the measurement the absolute error in the chargeability may only be about 5%, which is not significant. This problem is often encountered in very arid areas, e.g. parts of Peru, Chile and other desert regions.

Despite these slight effective differences both methods of I.P. exploration have amply demonstrated their value through important mineral discoveries in many parts of the world. The role of I.P. in mineral exploration is well acknowledged and rapidly expanding.

The writer wishes to thank the various sources of case histories and illustrations cited in the text and in particular, Dr. Keeva Vozoff and Dr. Philip Hallof for valuable contributions.

## Bibliography

- Bleil, D. F. (1953)  
"Induced Polarization, A Method of Geophysical Prospecting" – *Geophysics*, Vol. 18, pp. 636-661.
- Bodmer, R., Ward, S. H. and Morrison, H. F. (1968)  
"On Induced Electrical Polarization and Groundwater", *Geophysics*, Vol. 33, pp. 805-821.
- Dakhnov, B. N. (1941)  
"Electrical Well Logging, Interpretation of Electric Logs", Moscow, Chapter IV.
- Dieter, K., Paterson, N. R. and Grant, F. S. (1969)  
"I.P. and Resistivity Type Curves for Three Dimensional Bodies". *Geophysics*, Vol. 34, pp. 615-632.
- Hallof, P. G. (1957)  
"On the Interpretation of Resistivity and Induced Polarization Results" Doctoral Thesis, M.I.T. Department of Geology and Geophysics.
- Komarou, B. A. (1967)  
"Induced Polarization Method". Lecture read at Interregional Seminar of UNO on New Methods for Mineral Exploration with Emphasis on Geophysical Techniques. Moscow, U.S.S.R. July 1967.
- Madden, T. R. et al (1957)  
"Background Effects in the Induced Polarization Method of Geophysical Exploration", A.E.C. Report R.M.E. 3150.
- Marshall, D. J., and Madden, T. R. (1959)  
"Induced Polarization, a Study of its Causes" – *Geophysics* Vol. XXIV, pp. 790-816.
- Schlumberger, C. (1920)  
"Etude sur la Prospection Electrique du Sous Sol". Gauthier-Villars et Cie. Paris (1920) Chapter 8, (Revised 1930).
- Scott, W. J. and West, G. F. (1969)  
"Induced Polarization of Synthetic, High-Resistivity Rocks Containing Disseminated Sulphides" – *Geophysics*, Vol. 34, pp. 87-100.
- Seigel, H. O. (1948)  
"Theoretical Treatment of Selected Topics in Electromagnetic Prospecting" – National Research Council of Canada, Unpublished, pp. 34-53.
- Seigel, H. O. (1949)  
"Theoretical and Experimental Investigations into the Application of the Phenomenon of Overvoltage to Geophysical Prospecting" Unpublished Doctoral Dissertation, University of Toronto.
- Seigel, H. O. (1959)  
"Mathematical Formulation and Type Curves for Induced Polarization" *Geophysics* Vol. XXIV, pp. 547-563.
- Sunde, E. D. (1949)  
"Earth Conduction Effects in Transmission Systems" Van Nostrand Co., N. Y. (Monograph)
- Vacquier, V. et al (1957)  
"Prospecting for Ground Water by Induced Electrical Polarization" *Geophysics* Vol. 22, pp. 660-687.
- Wagg, D. M. and Seigel, H. O. (1963)  
"Induced Polarization in Drill Holes" *Can. Min. Journ.*, April.
- Wait, J. R. (Editor) (1959)  
"Overvoltage Research and Geophysical Applications" – Pergamon Press, London, 1959.

Additional copies of this reprint are available from:

Scintrex Limited,  
(HEAD OFFICE),  
222 Snidercroft Road,  
Concord, Ontario, Canada.  
Seigel Associates Limited,  
750-890 West Pender Street,  
Vancouver,  
British Columbia.  
Seigel Associates Limited,  
222 Snidercroft Road,  
Concord, Ontario, Canada.  
Scintrex Airborne  
Geophysics Inc.,  
4425-East 31st Street,  
Tulsa, Oklahoma, 74135.  
Seigel Associates Limited,  
115 Moorgate,  
London EC2, England.

Seigel Associates  
(International) Ltd.,  
P.O. Box 627,  
30 Duke Street,  
Kingston, Jamaica.  
Mineral Surveys Inc  
(Western Division),  
178 West 2950 South,  
Salt Lake City,  
Utah, 84115.  
Seigel Associates  
Australasia Pty. Ltd.,  
11 King Street, Boulder,  
West Australia, 6432.  
Seigel Asociados S.A.  
de C.V., Av. Hangares  
de Aviacion No. 41,  
Mexico 9, D.F.



**SCINTREX**



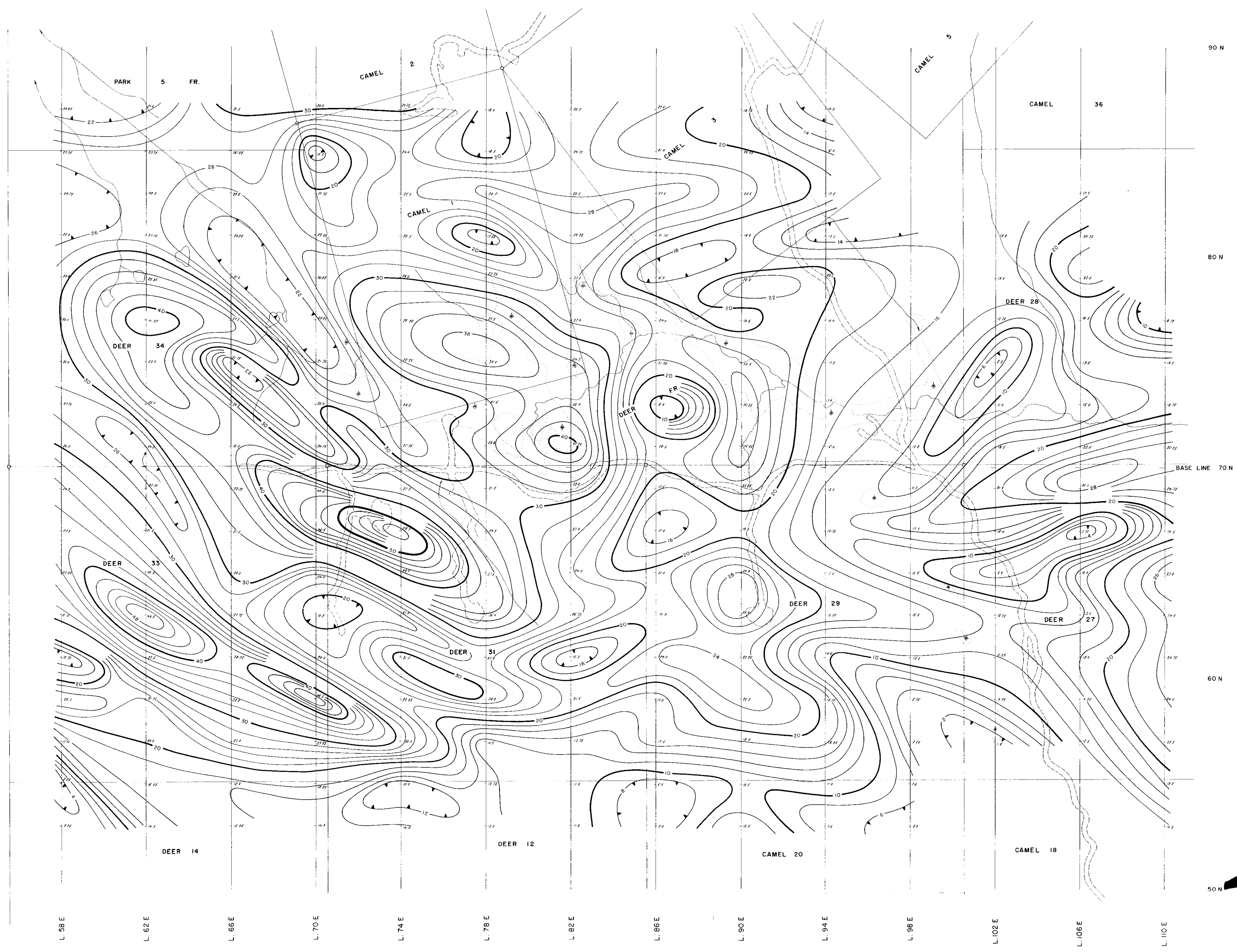

4867 M3

LEGEND  
 CONTOUR INTERVAL  
 10, 50 MILLISECOND  
 10, 20 MILLISECOND  
 2, 4 MILLISECOND  
 DEPRESSION

Department of Mines and Technical Surveys ASSESSMENT REPORT NO. 4867 MAP #3
AMAX EXPLORATION INC. DEER PARK PROPERTY, CASTLEGAR AREA, B.C. <b>CHARGEABILITY CONTOUR PLAN</b> n = 3 SCINTREX MARK VII 2.5 kw UNIT
SCALE: 1" = 200' TO ACCOMPANY A GEOPHYSICAL REPORT BY P.R. BAILEY AND M. LEWIS DATED DECEMBER 1973
SURVEY BY SCINTREX SURVEYS LTD NOVEMBER 1973

PLATE 1



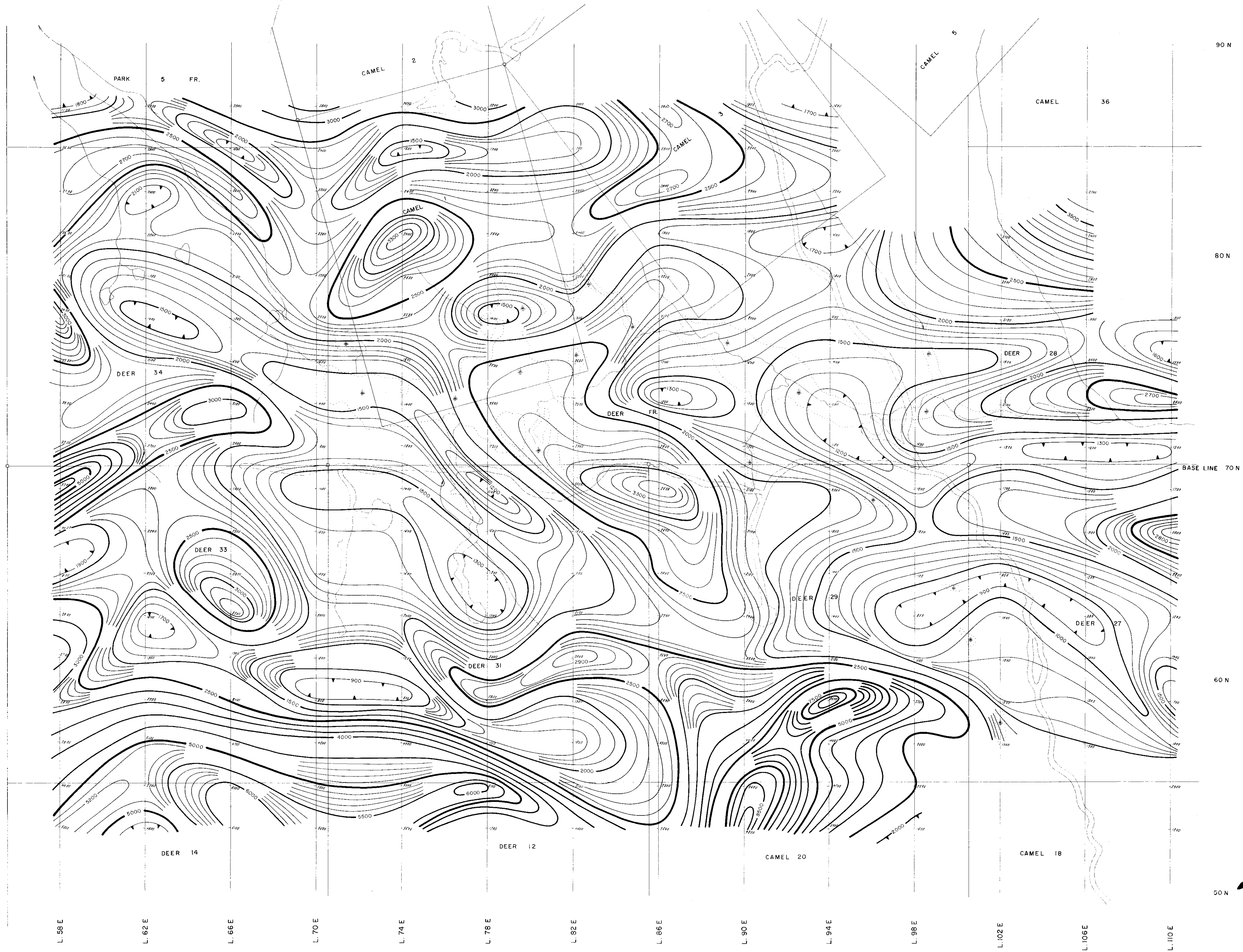

**LEGEND**

CONTOUR INTERVAL ..... 100 OHM-METERS

10, 2500 OHM-METERS .....

500, 1000 OHM-METERS .....

100, 200 OHM-METERS .....

DEPRESSION .....

**4867 M4**

NO. 4867 MAP #4

AMAX EXPLORATION INC.	
DEER PARK PROPERTY, CASTLEGAR AREA, B.C.	
<b>RESISTIVITY CONTOUR PLAN</b>	
n = 3	
SCINTREX MARK VII 2.5 kw UNIT	
SCALE: 1" = 200'	
SURVEY BY SCINTREX SURVEYS LTD. NOVEMBER 1973	<b>PLATE 2</b>

TO ACCOMPANY A GEOPHYSICAL REPORT  
BY P.R. BAILEY AND M. LEWIS DATED DECEMBER 1973



L. 58 E

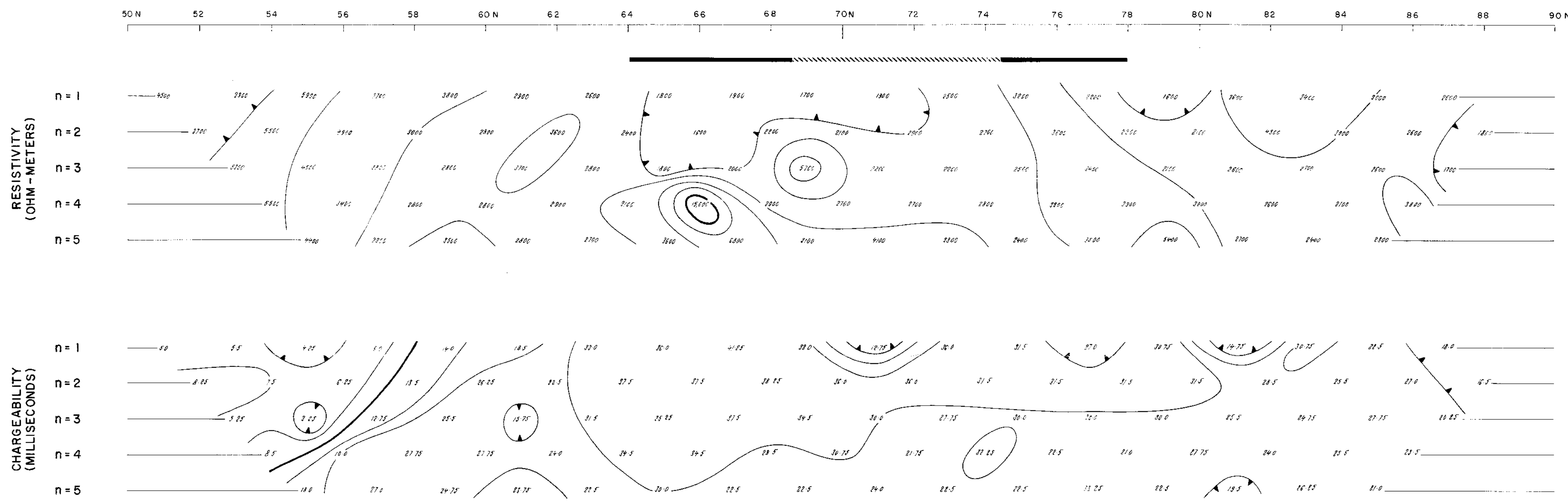

L. 62 E

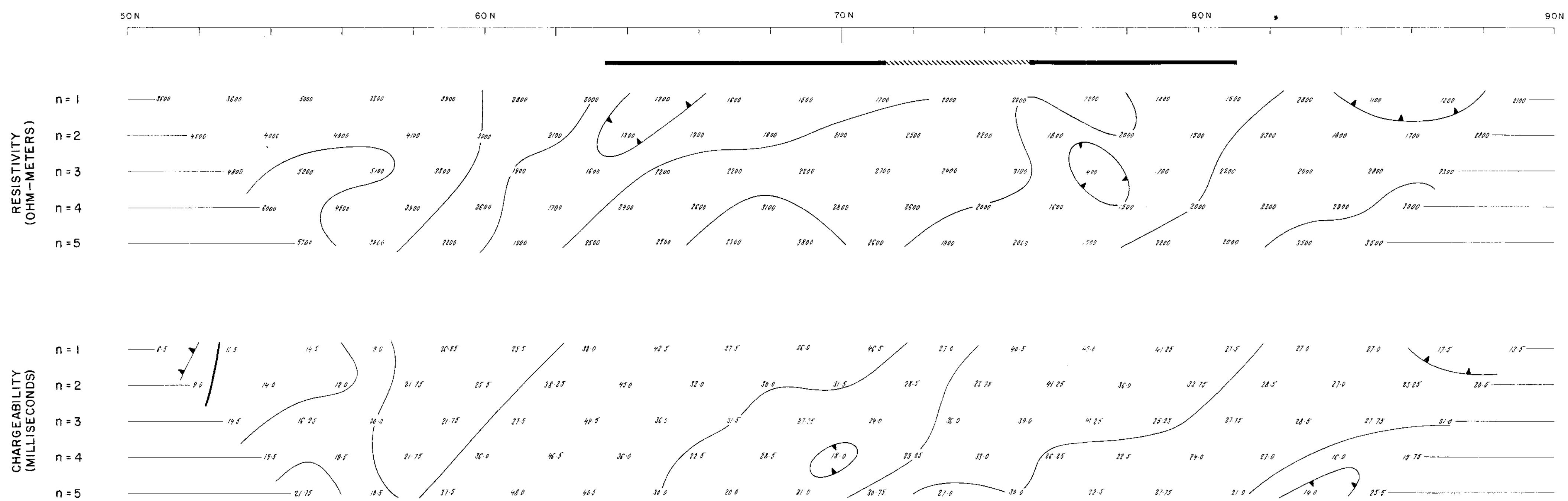

L. 66 E

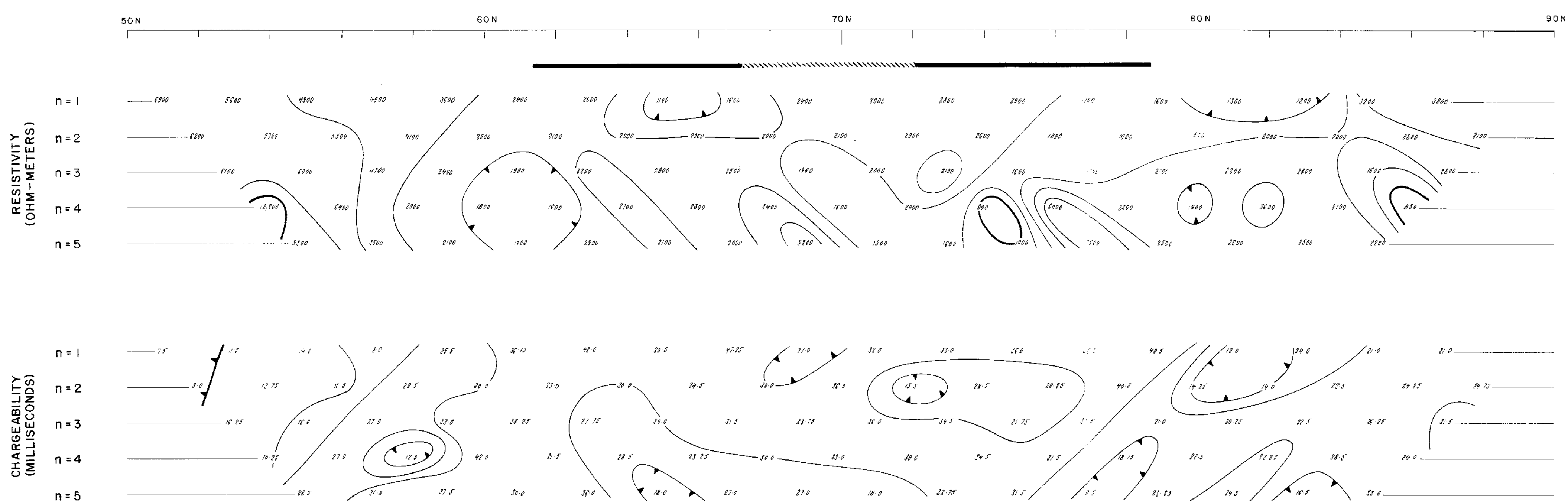

L. 70 E

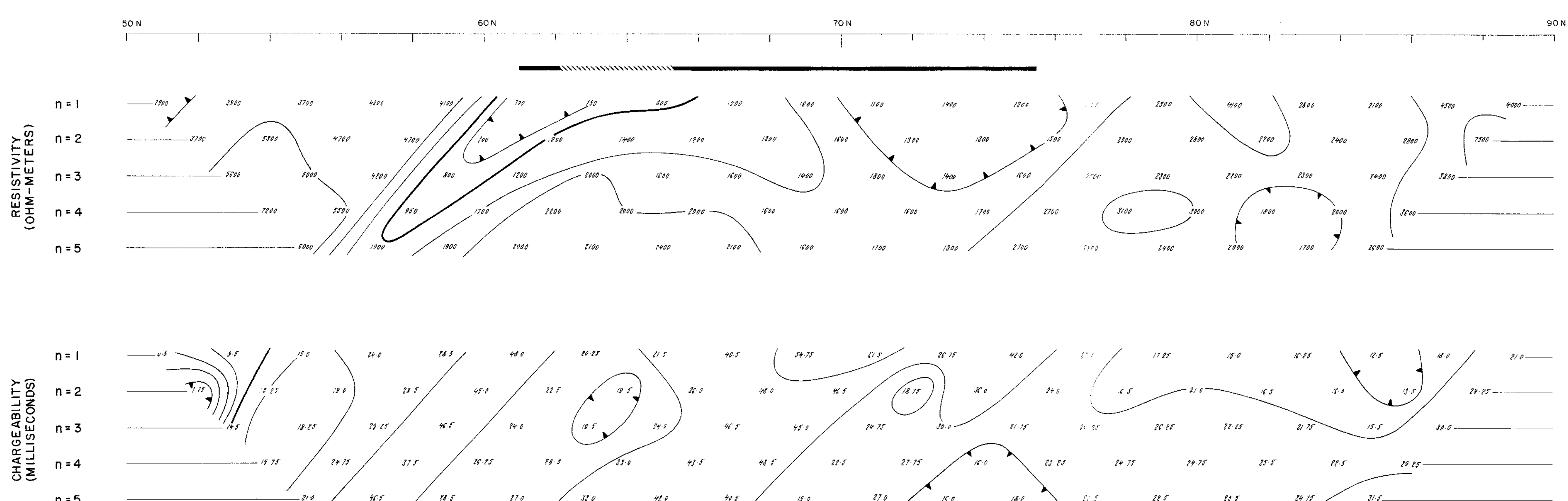

**LEGEND**  
 POLE-DIPOLE  
 CURRENT ELECTRODE TO SOUTH  
 LOGARITHMIC CONTOUR INTERVALS AT MULTIPLES OF RESISTIVITY  
 100, 1000  
 500, 2000, 5000, 7500  
 CHARGEABILITY  
 1, 10, 100  
 15, 2, 3, 5, 75  
**ANOMALY SYMBOLS**  
 DEFINITE  
 POSSIBLE

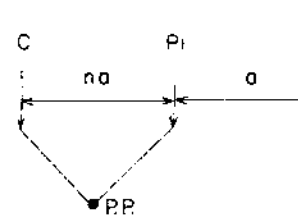

**4867**  
**M5**

4867 #5

AMAX EXPLORATION INC.  
 DEER PARK PROPERTY, CASTLEGAR AREA, B.C.  
**INDUCED POLARIZATION SURVEY**  
 PSEUDO-SECTIONS  
 SCINTREX MARK VII 2.5kw UNIT  
 SCALE: 1" = 200'  
 SURVEY BY SCINTREX SURVEYS LTD. NOVEMBER 1973  
 PLATE 3

TO ACCOMPANY A GEOPHYSICAL REPORT  
 BY P.R. BAILEY AND M. LEWIS DATED DECEMBER 1973

L. 74 E

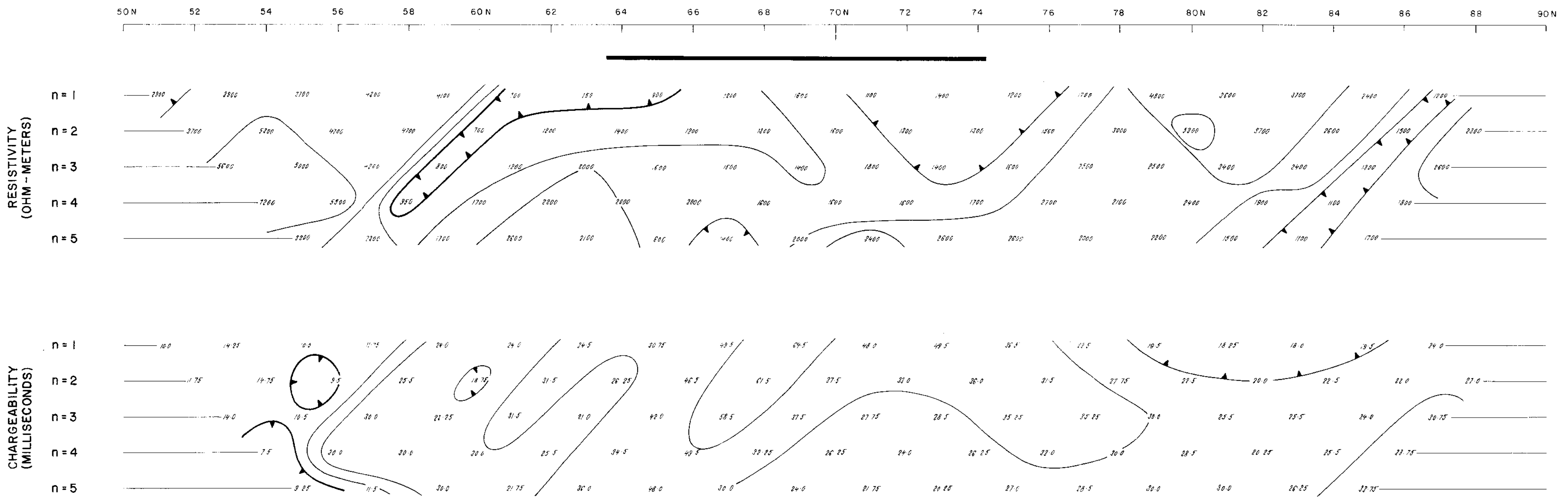

L. 78 E

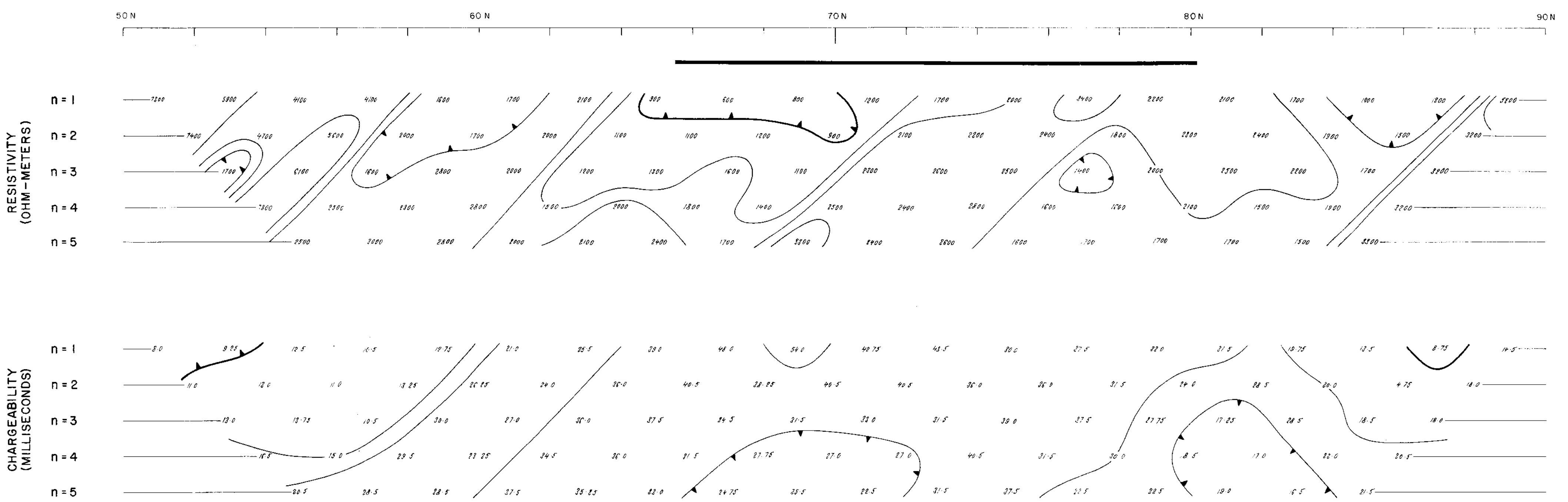

L. 82 E

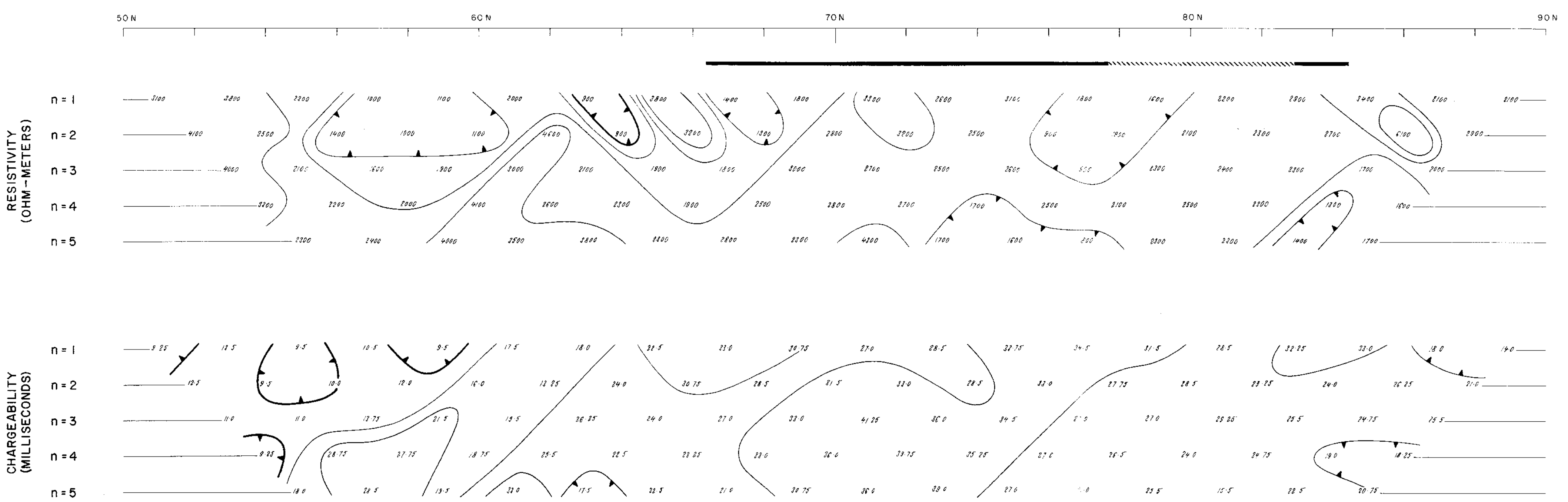

L. 86 E

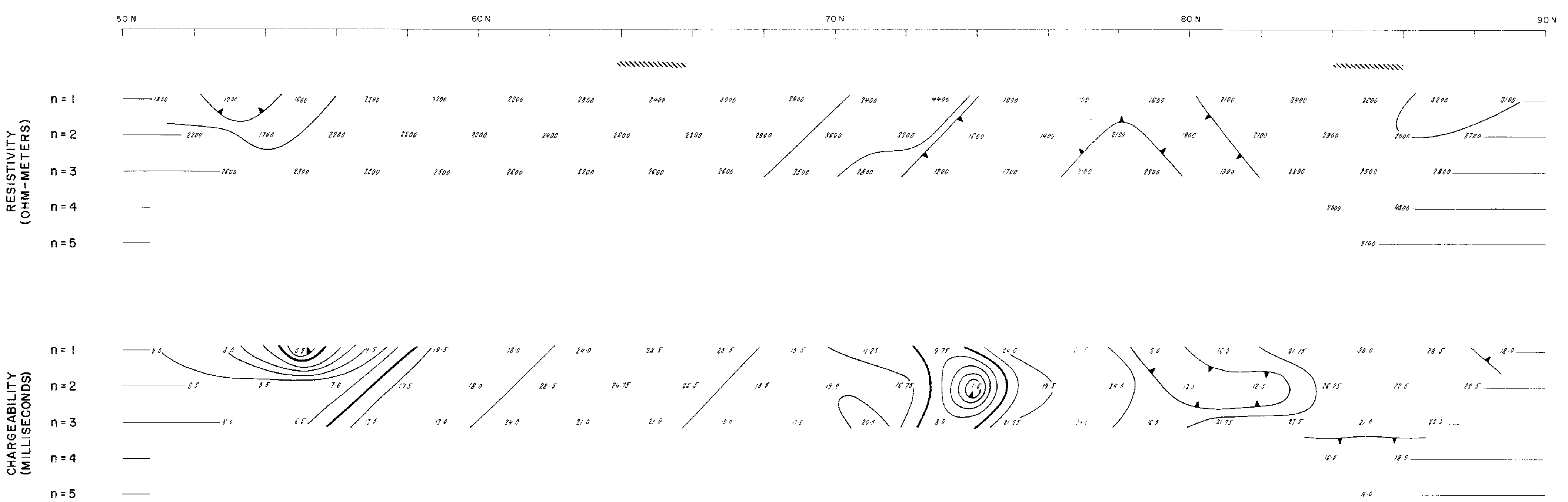

LEGEND

- POLE-DIPOLE CURRENT ELECTRODE TO SOUTH
- LOGARITHMIC CONTOUR INTERVALS AT MULTIPLES OF RESISTIVITY
  - 100, 500
  - 100, 500, 1000, 500, 750
- CHARGEABILITY
  - 1, 10
  - 1.5, 2, 3, 5, 7.5
- ANOMALY SYMBOLS
  - DEFINITE
  - POSSIBLE

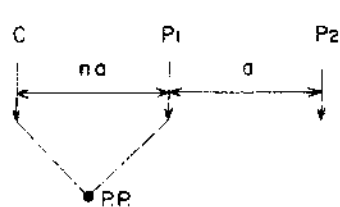

**4867** - ②  
**M6**

NO. 4867 #6
AMAX EXPLORATION INC.
DEER PARK PROPERTY, CASTLEGAR AREA, B.C.
INDUCED POLARIZATION SURVEY PSEUDO-SECTIONS SCINTREX MARK VII 2.5 kw UNIT
SCALE: 1" = 200'
SURVEY BY SCINTREX SURVEYS LTD. NOVEMBER 1973
PLATE 4

TO ACCOMPANY A GEOPHYSICAL REPORT  
BY P.R. BAILEY AND M. LEWIS DATED DECEMBER 1973

L. 90 E

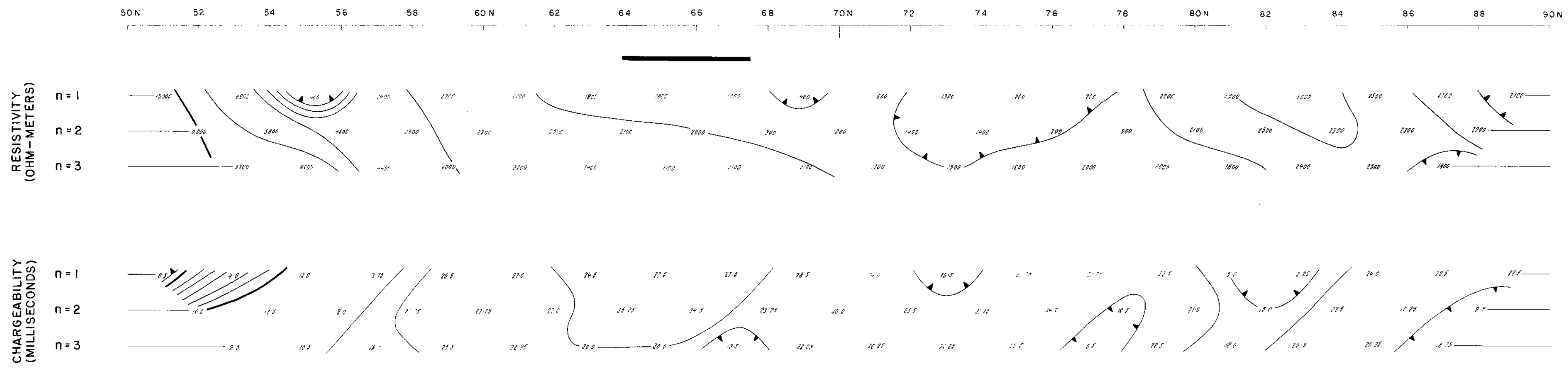

L. 94 E

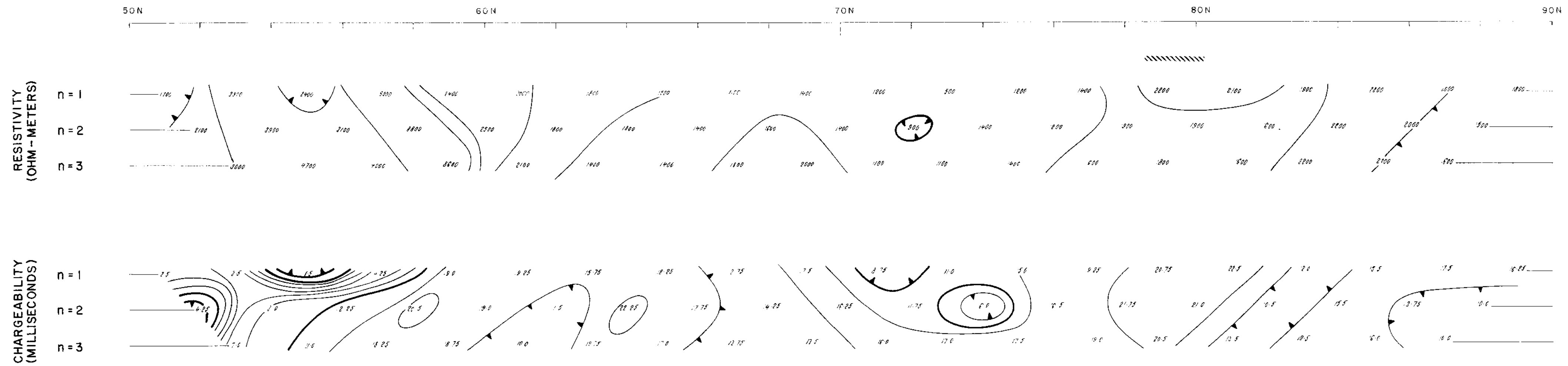

L. 98 E

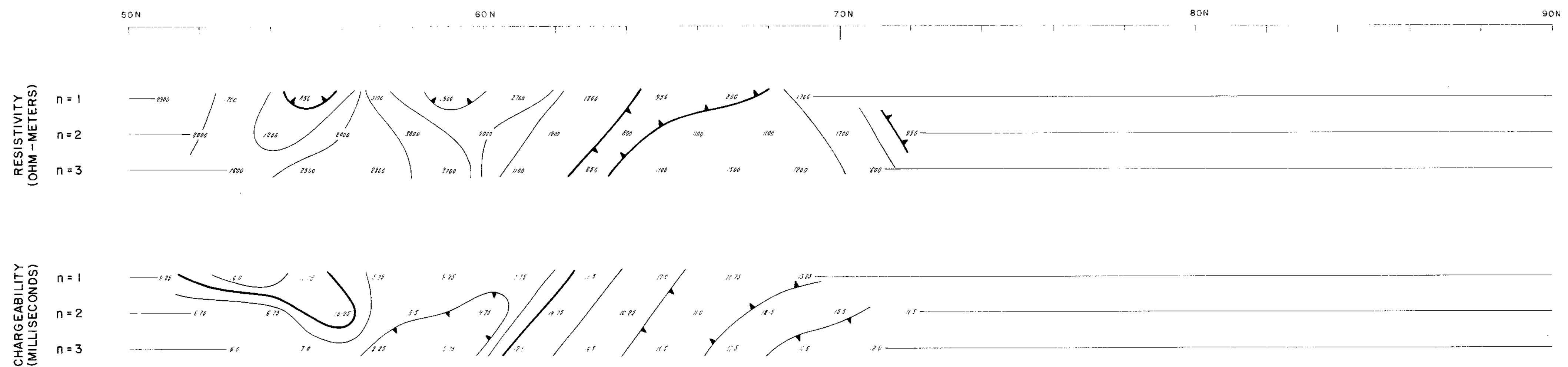

L. 102 E

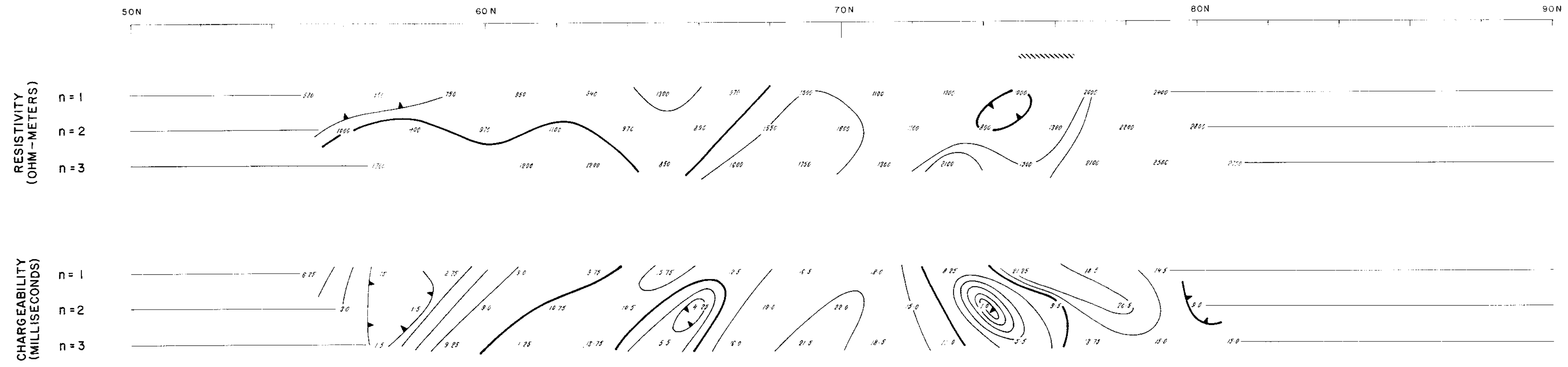

L. 106 E

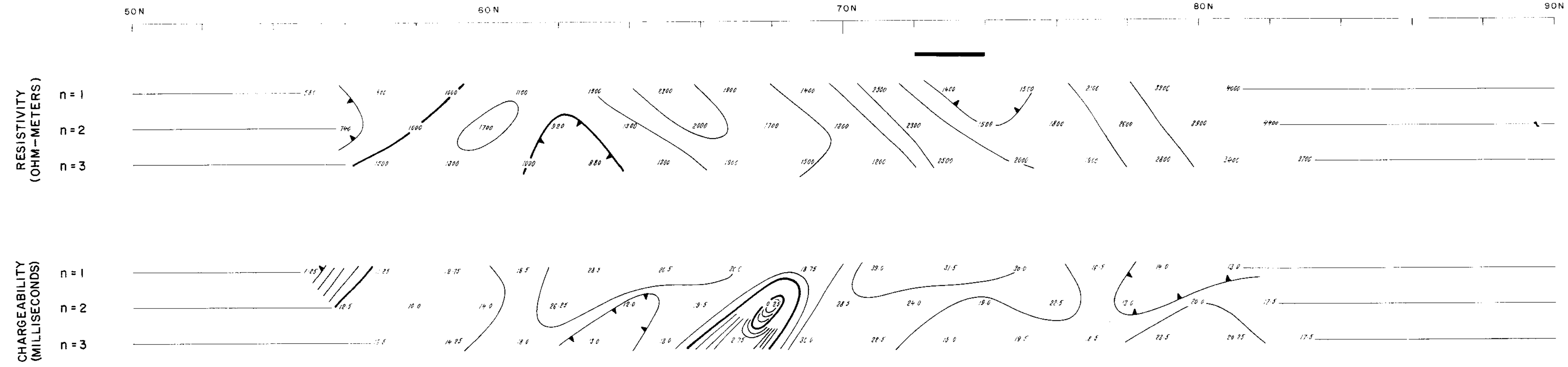

L. 110 E

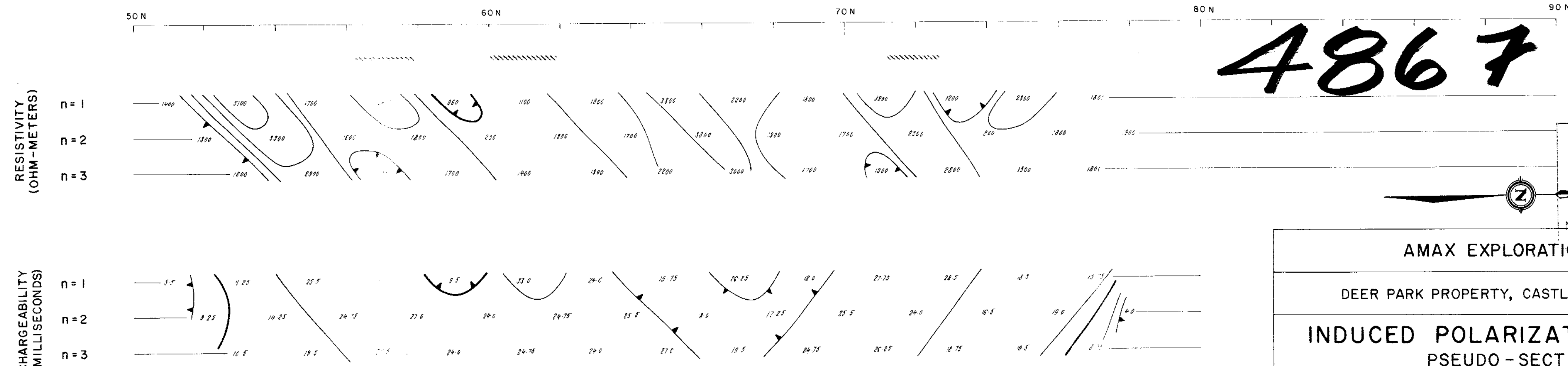

4867 M7

**LEGEND**

POLE-DIPOLE  
CURRENT ELECTRODE TO SOUTH  
LOGARITHMIC CONTOUR INTERVALS AT MULTIPLES OF RESISTIVITY  
100,000  
100,000,300,500,750,  
CHARGEABILITY  
1, 10,  
15, 2, 3, 5, 7.5.

**ANOMALY SYMBOLS**  
DEFINITE  
POSSIBLE

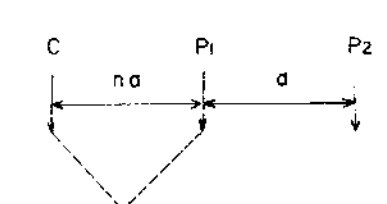

4867 #7

AMAX EXPLORATION INC.  
DEER PARK PROPERTY, CASTLEGAR AREA, B.C.

**INDUCED POLARIZATION SURVEY**  
PSEUDO-SECTIONS  
SCINTREX MARK VII 2.5kw UNIT

SCALE: 1" = 200'

TO ACCOMPANY A GEOPHYSICAL REPORT  
BY P.R. BAILEY AND M. LEWIS DATED DECEMBER 1973

SURVEY BY  
SCINTREX SURVEYS LTD.  
NOVEMBER 1973

PLATE 5



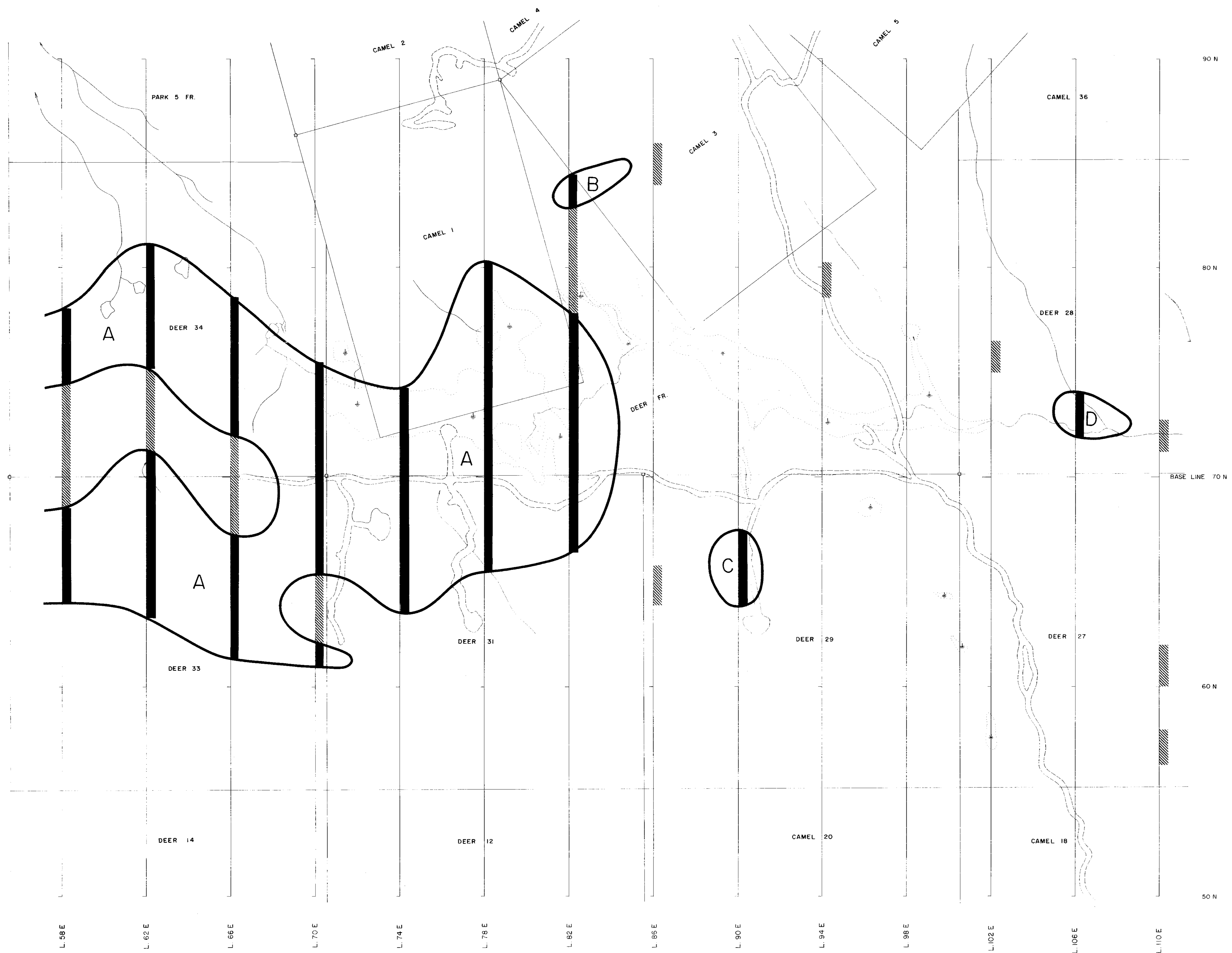

4867 MB

NO. 4867 #8

**LEGEND**  
 DEFINITE ANOMALY .....  
 POSSIBLE ANOMALY .....  
 INTERPRETED OUTLINE OF POLARIZABLE BODY PROJECTED TO SURFACE .....

AMAX EXPLORATION INC.	
DEER PARK PROPERTY, CASTLEGAR AREA, B.C.	
<b>ANOMALOUS ZONE PLAN</b>	
SCALE: 1" = 200'	
 SURVEY BY SCINTREX SURVEYS LTD NOVEMBER 1973	PLATE 6 <small>Approved under Order S. 1974</small>

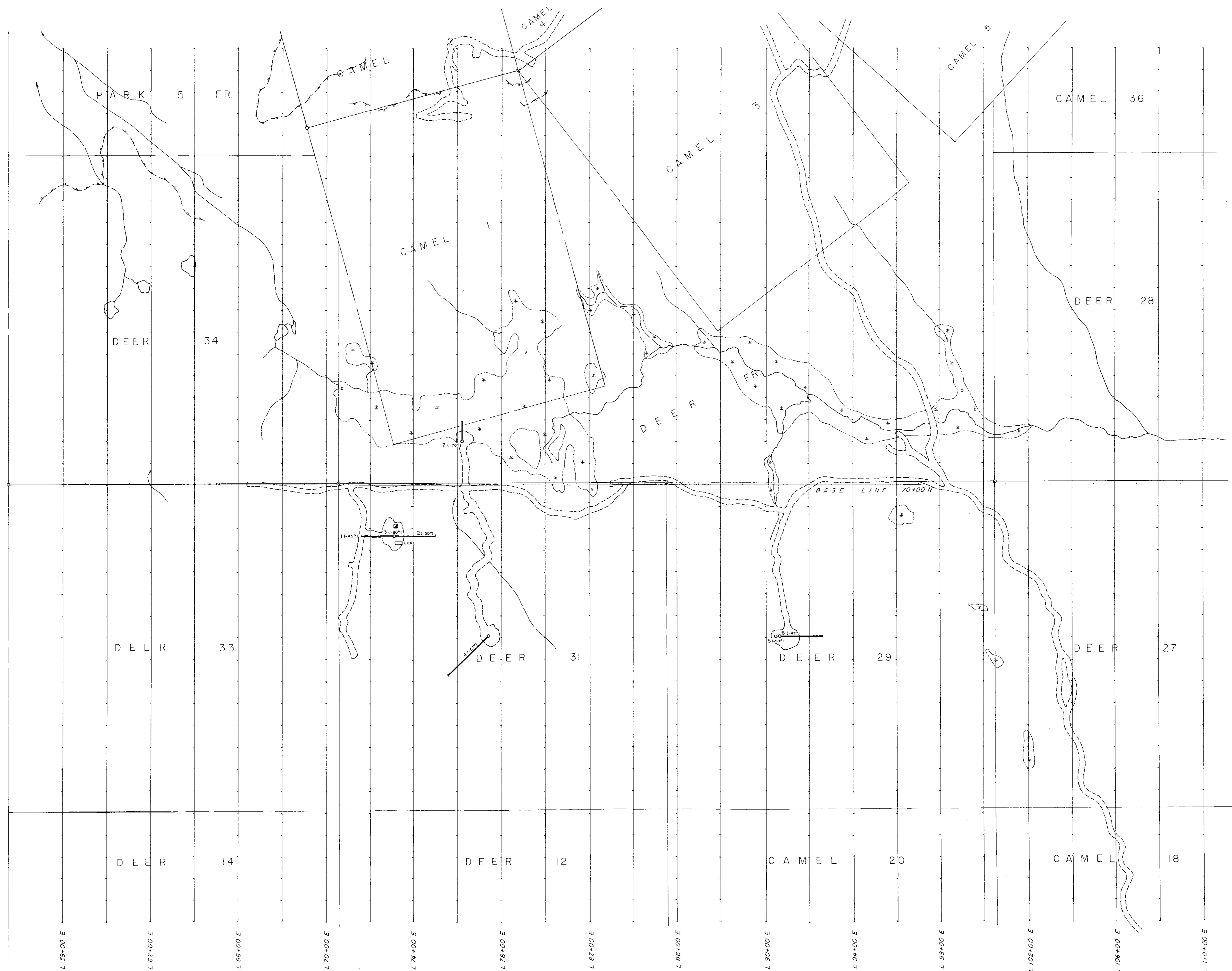

90+00 N  
80+00 N  
60+00 N  
50+00 N

Department of  
Mineral Resources  
4867 #9

TO ACCOMPANY A REPORT ON AN  
INDUCED POLARIZATION SURVEY  
ON THE DEER PARK PROPERTY.  
Deer 11-20, 27, 28, 29, 31-40, Doer Fr.,  
Park Fr. Park 5 Fr., Park 6-12, 14-24, Camel 1-42  
mineral claims  
Trail Creek M.D.  
Coordinates: 118002'W 49020'N  
By: Sciencex Surveys Ltd.  
For: Amex Exploration, Inc.  
Work Done - October 19 - Nov. 8, 1973

4867  
M9