

'85-10-# 13430



HARDY ASSOCIATES (1978) LTD.
CONSULTING ENGINEERING & PROFESSIONAL SERVICES

MAGNETIC AND VERY LOW FREQUENCY
ELECTROMAGNETIC SURVEYS
CARIBOO AREA, B.C. 1984

CLAIMS 5102(8), 5100(8), 5132(9), 5119(8), 5111(8),
5543(11), 5575(12), 5050(8), 5012(7), 5013(7), 4994(7),
4995(7), 439166-439171, 88211, 88212, 88213
Latitude 52°20'N Longitude 121°25'W
NTS 93A/3, 5, 6, 12

Prepared for:
ASAMERA INC.
Suite 2100, 144-4 Avenue S.W.
Calgary, Alberta

By:
HARDY ASSOCIATES (1978) LTD.
Calgary, Alberta

**GEOLOGICAL BRANCH
ASSESSMENT REPORT**

September, 1984

CG-12049

0.15

13,430
part 3 of 3



TABLE OF CONTENTS

		<u>Page</u>
1.0	INTRODUCTION	1
1.1	Property and Ownership - Rick Grid	1
1.2	Property and Ownership - Golden Falls Grid	2
1.3	Property and Ownership - Golden Cat Grid	3
1.4	Property and Ownership - Hot Grid	4
1.5	Exploration History	5
1.6	Itemized Cost Statement	6
2.0	EQUIPMENT	6
2.1	Magnetometer	6
2.2	VLF-EM	7
3.0	FIELD PROCEDURE	7
3.1	Magnetic Survey	7
3.2	VLF-EM Survey	7
4.0	SURVEY RESULTS	8
4.1	Rick Grid	8
	4.1.1 Magnetics	8
	4.1.2 VLF	9
4.2	Golden Falls Grid	10
	4.2.1 Magnetic Survey	10
	4.2.2 VLF Survey	10
4.3	Golden Cat Grid	11
	4.3.1 Magnetic Survey	11
	4.3.2 VLF Survey	12
4.4	Hot Grid	12
	4.4.1 Magnetic Survey	12
	4.4.2 VLF Survey	13
5.0	SUMMARY	13



LIST OF APPENDICES

- APPENDIX "A" - Principles and Operating Procedure of VLF
Instruments
- APPENDIX "B" - Generation of VLF Anomalies
- APPENDIX "C" - Field and Base Station Magnetometers

LIST OF PLATES

- Plate 1 - RICK GRID - Magnetic Contours
- Plate 2 - RICK GRID - Fraser Filtered VLF Data
- Plate 3 - GOLDEN FALLS GRID - Magnetic Contours
- Plate 4 - GOLDEN FALLS GRID - Fraser Filtered VLF Data
- Plate 5 - GOLDEN CAT GRID - Magnetic Contours
- Plate 6 - GOLDEN CAT GRID - Fraser Filtered VLF Data
- Plate 7 - HOT GRID - Magnetic Contours
- Plate 8 - HOT GRID - Fraser Filtered VLF Data
- Plate 9 - RICK GRID - Magnetometer Readings
- Plate 10 - RICK GRID - VLF Dip
- Plate 11 - RICK GRID - VLF Quadrature
- Plate 12 - GOLDEN FALLS GRID - Magnetometer Readings
- Plate 13 - GOLDEN FALLS GRID - VLF Dip
- Plate 14 - GOLDEN FALLS GRID - VLF Quadrature
- Plate 15 - GOLDEN CAT GRID - Magnetometer Readings
- Plate 16 - GOLDEN CAT GRID - VLF Dip
- Plate 17 - GOLDEN CAT GRID - VLF Quadrature
- Plate 18 - HOT GRID - Magnetometer Readings
- Plate 19 - HOT GRID - VLF Dip
- Plate 20 - HOT GRID - VLF Quadrature



1.0 INTRODUCTION

From June 28, 1984 to July 18, 1984, Hardy Associates (1978) Ltd. carried out a magnetic and a very low frequency electromagnetic (VLF-EM) survey on four grids in the Cariboo Mining Division of south-central B.C., near the eastern boundary of the Interior Plateau physiographic region. The four grids are in the vicinity of Horsefly, B.C., as shown in Figure 1. The field work was carried out by W. Hemstock, B.Sc. and D. Palos, B.Sc., of Hardy Associates (1978) Ltd. The survey consisted of 147 line-kilometres of VLF-EM and 150 line-kilometres of magnetometer survey.

1.1 PROPERTY AND OWNERSHIP - RICK GRID

The Rick property is comprised of three claim blocks totalling approximately 2950 acres. The property was acquired in late 1983 through an outright cash purchase agreement, subject to a 7.5% NPI. There are no work commitments relating to the claims and in each case ownership is 100% Asamera. Property data is summarized in Table 1.

TABLE 1

<u>NAME</u>	<u>RECORD #</u>	<u>RECORD DATE</u>	<u>UNIT *</u>	<u>ACREAGE</u>	<u>EXPIRY DATE+</u>
Impasse	5102(8)	Aug. 23/83	20 (16.77)	1036	Aug. 23/86
Goldmaster	5100(8)	Aug. 23/83	20 (12.92)	798	Aug. 23/86
Rick	5132(9)	Sept 16/83	18	1112	Sept 16/86
			<hr/>	<hr/>	
			47.69	2946	

* Figure in brackets indicates size of claim (approx.) after originally staked claim was reduced in size as a result of prior staking

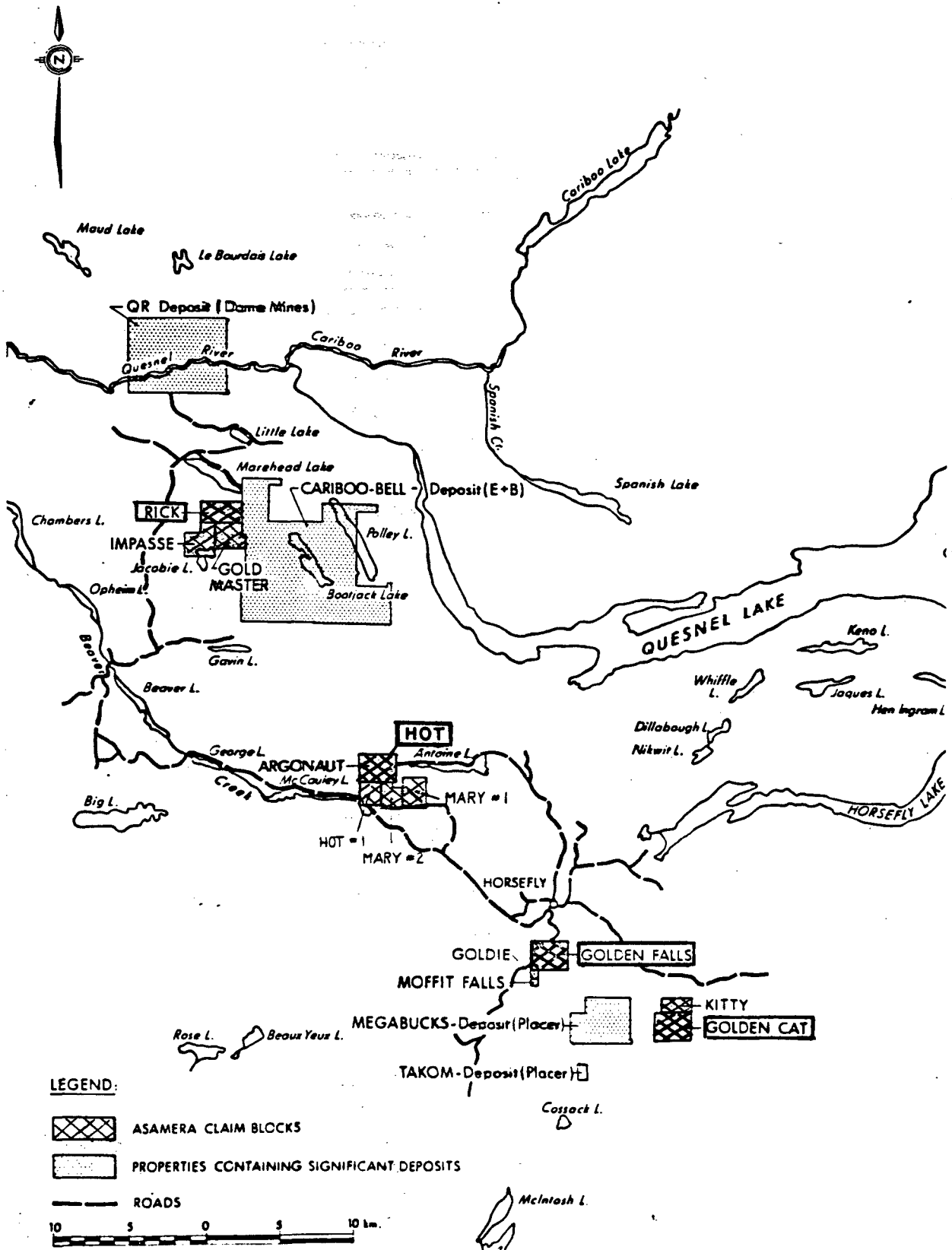

NTS 93A / 5, 6, 12



HARDY ASSOCIATES (1978) LTD.
CONSULTING ENGINEERING & PROFESSIONAL SERVICES

ASAMERA INC.
LOCATION MAP
CARIBOO GOLD PROJECT

CG12049



+ Reflects the submission of the linecutting only. To be amended after the technical data has been submitted for assessment credit.

The property is situated in the Cariboo Mining Division, approximately 60 kilometres northeast of Williams Lake in south-central B.C. Good access onto the claims is provided by a network of logging roads leading from Horsefly, a small community in the center of the project area, which is accessible by main roads from Williams Lake.

1.2 PROPERTY AND OWNERSHIP - GOLDEN FALLS GRID

The Goldie Property comprises one claim block - Golden Falls and two 2 post claims - Goldie and Moffat Falls, totalling approximately 1360 acres. The property was acquired in late 1983 through an outright cash purchase agreement subject to a 7.5% NPI. There are no work commitments relating to the claims and in each case ownership is 100% Asamera. Property data is summarized in Table 2.

TABLE 2

<u>NAME</u>	<u>RECORD #</u>	<u>RECORD DATE</u>	<u>UNITS</u>	<u>ACREAGE</u>	<u>EXPIRY DATE+</u>
Golden Falls	5051(8)	Aug. 9/83	20	1236	Aug. 9/85
Goldie	5012(7)	July 29/83	1	62	July 29/87
Moffat Falls	5013(7)	July 29/83	1	62	July 29/86
			<hr/> 22	<hr/> 1360	

+ Reflects the submission of the linecutting only. To be amended after the technical data has been submitted for assessment credit.



The property is situated in the Cariboo Mining District approximately 40 kilometres east of Williams Lake in south central B.C.

Good access to the claims is provided by two well maintained secondary (gravel) roads leading from Horsefly, a small community about 5 kilometres to the north.

1.3 PROPERTY AND OWNERSHIP - GOLDEN CAT GRID

The Kitty property is comprised of two claim blocks, six 2 post claims and three fractional claims totalling approximately 2200 acres. The two claim blocks were acquired in late 1983 through an outright cash purchase agreement subject to a 7.5% NPI. The six two post claims and two fractional claims were staked by Asamera in May '84. There are no work commitments relating to the claims and in each case ownership is 100% Asamera. Property data is summarized in Table 3.

TABLE 3

<u>NAME</u>	<u>RECORD #</u>	<u>RECORD DATE</u>	<u>UNITS</u>	<u>ACREAGE</u>	<u>EXPIRY DATE+</u>
Kitty	4994(7)	July 26/83	8	494	July 26/85
Golden Cat	4995(7)	July 26/83	20	1236	July 26/85
Char 1 - 6	439166 -				
	439171	May 5/84	6	372	May 5/85
Coal (Fr)	88211	June 8/84	Fraction	40	June 8/85
Coal 1 (Fr)	88212	June 8/84	Fraction	38	June 8/85
Coal 2 (Fr)	88213	June 8/84	Fraction	20	June 8/85
				<u>2200</u>	

+ Reflects the submission of the linecutting only. To be amended after the technical data has been submitted for assessment credit.



The property is situated in the Cariboo Mining Division approximately 45 kilometres east of Williams Lake in south central B.C. Access to the east edge of the claims is provided by a logging road leading from Horsefly, a small community approximately 15 kilometres northwest of the property.

1.4 PROPERTY AND OWNERSHIP - HOT GRID

The Hot property comprises four claim blocks totalling approximately 3050 acres. The Argonaut and Hot #1 claim blocks were acquired in late 1983 through an outright cash purchase agreement subject to a 7.5% NPI. The two additional blocks Mary and Mary #2 were later acquired with no overriding royalties. There are no work commitments relating to the claims and in each case ownership is 100% Asamera. Property data is summarized in Table 4.

TABLE 4

<u>NAME</u>	<u>RECORD #</u>	<u>RECORD DATE</u>	<u>UNIT *</u>	<u>ACREAGE</u>	<u>EXPIRY DATE+</u>
Argonaut	5119(8)	Aug. 26/83	20	1236	Aug. 26/86
Hot #1	5111(8)	Aug. 26/83	9	556	Aug. 26/86
Mary	5543(11)	Nov. 29/83	12	741	Nov. 29/86
Mary #2	5575(12)	Dec. 9/83	12 (8.16)	504	Dec. 9/86
				<u>3037</u>	

* Figures in brackets indicate size of claim after originally staked claim was reduced in size as a result of prior staking

+ Reflects the submission of the linecutting only. To be amended after the technical data has been submitted for assessment credit.



The property is situated in the Cariboo Mining Division approximately 60 km northeast of Williams Lake in south-central B.C.

Good access to the claims is provided by a network of logging roads leading from the Beaver Valley Road, a well maintained secondary road (gravel) between the small villages of Horsefly and Likely.

1.5 EXPLORATION HISTORY

Although the copper showings in this historic gold placer mining area probably were known locally for decades, no record exists of their exploration before 1964 when Mastoden-Highland Bell Mines Limited, jointly with Leitch Gold Mines Limited, discovered copper oxides at the site of a prominent aeromagnetic anomaly indicated by newly published federal-provincial surveys.

Results of initial work led to the formation of a new company, Cariboo-Bell Copper Mines Limited, which began drilling in 1966 and was joined subsequently by a consortium of Japanese companies that later withdrew on recognition of metallurgical difficulties resulting from the degree of oxidation of the deposit. In 1969, Teck Corporation acquired control of Cariboo-Bell Copper Mines Limited. E & B began work on the claims in 1981 and acquired control of the property in 1982. Total drilling on the property amounts to 120,940 feet including 77,662 feet of diamond drilling.

Several other gold deposits in the area were originally tested for their porphyry copper potential. These include the



Megabucks and Takom deposits which were staked as copper showings by Exploram in 1971. An initial program of reconnaissance I.P. and magnetic surveys, soil and rock sampling and diamond drilling outlined the two zones mentioned above which are currently being tested by Placer Development Ltd.

In addition to the above, early in 1983 Dome announced they had defined one million tons grading 0.2 ounces per ton gold on their QR deposit and that they were embarking on a major drill program. Although the results of the drilling are not yet public, Dome's initial success prompted an extensive staking rush in the area during the last half of 1983 and at least one other significant find (Eureka) was made.

1.6 ITEMIZED COST STATEMENT

The cost of the survey is as described below:

147 km of combined VLF and Magnetometer @ 135	19,845
3 km of magnetometer @ 70	210
Total Cost	<u>20,055</u>

2.0 EQUIPMENT

2.1 MAGNETOMETER

The magnetic measurements were made with an EDA PPM 350 Total Field Magnetometer. In order to correct the field observations for diurnal variations in the magnetic field an EDA PPM 375 Recording Base Station Magnetometer was used. Both the field and base station magnetometers were equipped



with digital memories to store data for the duration of the day. A detailed description of the field magnetometer is given in Appendix C.

2.2 VLF-EM

A Geonics EM 16 was used to carry out the VLF-EM survey. The sensor in the EM 16 is a signal coil with a small reference coil mounted orthogonally. This instrument measures the tilt and ellipticity of the VLF electromagnetic field. The tilt or dip angle are given as percent of the total primary field. The ellipticity or quadrature is also given as a percentage of the total primary field. A complete description of the Geonics EM 16 is included as Appendix A.

3.0 FIELD PROCEDURE

3.1 MAGNETIC SURVEY

Magnetic base stations were established for each grid. The locations of the base stations are shown on the contour maps of total magnetic field intensity. Readings were taken with the field magnetometer on the grid at 25 m intervals. At the end of the survey day the data sets from the field magnetometer and the base station were merged to provide magnetic readings corrected for diurnal variations. A base value of 56000 nanoTeslas (nT) was subtracted from all of the readings.

3.2 VLF-EM SURVEY

The transmitter NSS (Seattle, Washington) was used for the VLF survey on all four grids. VLF-EM dip angle and quadrature



measurements were recorded on voice tape recorder during the survey. These notes were transcribed to computer files. The slope of the ground surface between VLF stations was measured with a hand level. These slope measurements were used to apply a topographic correction to the VLF dip angle measurement.

The topographically corrected VLF dip angle data were processed with a Fraser filter and the results were contoured. Note that the Fraser filter values can only be calculated to within 62.5 m of the ends of the line.

4.0 SURVEY RESULTS

4.1 RICK GRID

4.1.1 Magnetics

The magnetic contours for the Rick Grid are shown on Plate 1. A value of 56,000 nT has been subtracted for all contour values.

The most obvious feature of the magnetic contour map is a general northwest trend. In addition a uniform level of magnetic relief is observed on most of the map.

There are five areas where the character of the magnetic contours is different from the general trends. The largest of these is an area of low magnetic relief which trends northwest from Jacobie Lake. There is a suggestion that the area may be circular but both ends are open at the property boundaries. The lack of magnetic relief in this area may be due to a less



magnetic rock underlying the area or due to deeper overburden.

The area from 400 W to 1500 E which is bounded on the north by Line 10S has a slight east-west trend. The trend is less developed than on the rest of the grid.

North of Line 10S is an area of higher magnetic relief that extends from 600 E to 1500 E and is bounded on the north by Line 4S. A significant high is centred at 750E between Lines 6S and 4S. Another area of high magnetic activity is located east of 1000E between Lines 2N and 10N. The trend of the contours is more northerly than on the rest of the grid.

The fifth area of different character is located north of Line 12N and east of the base line. The magnetic trend is similar to the rest of the grid but the magnetic relief is higher. A significant area of low magnetic intensity is centred at 450E between Lines 14N and 16N.

4.1.2 VLF

The general trend of the conductors derived from the Fraser filtered VLF data is in good agreement with the trend observed in the magnetic contours. The conductivities of the conductors on this grid range from poor to moderate. None of the conductors has sufficient amplitude to suggest that massive sulphides have been detected.

The area northwest of Jacobie Lake has only one poor conductor. This is in agreement with the lack of magnetic activity in this area.



The highest amplitude conductor on the grid is located on Line 6S at 400E. However, an anomaly with a peak amplitude of 60% is not expected to be due to a sulphide conductor.

4.2 GOLDEN FALLS GRID

4.2.1 Magnetic Survey

The magnetic contours for the Golden Falls grid are shown on Plate 3. The contour interval is 50 nT and 56,000 nT has been subtracted from all values.

The magnetic level changes from the west to east by approximately 200 nT. The level change occurs across a line extending from 400W at the south boundary to 1000W at the north boundary. To the west of this line there is a NNE trend to the contours.

To the east of the level change, there is a circular pattern centred at 150E on Line 4N.

4.2.2 VLF Survey

The contours of Fraser filtered VLF dip angles are shown on Plate 4. The contour interval is 10%.

The most prominent conductor outlined by the VLF contours coincides with the magnetic level change. The magnetics indicate that this is a boundary between two lithological units while the VLF indicates that there is probably a fault between the two units. The peak amplitude of the VLF anomaly (60%) is too low to indicate massive sulphides.



East of the fault there is general agreement between the magnetic trends and the VLF trends. The VLF conductors appear to be due to structural effects associated with the circular feature outlined by the magnetics.

On the western part of the grid there are three higher amplitude conductors in the southern part of the area. The conductor centred at 1200W is oriented approximately 60°E of the trend of the magnetic contours and the other conductors in the southwest area.

The VLF anomalies in the northwest part of the grid trend in a northerly direction. None of the anomalies in this area are significant conductors.

4.3 GOLDEN CAT GRID

4.3.1 Magnetic Survey

The magnetic contours for the Golden Cat grid are shown on Plate 5. The contour interval is 100 nT and 56,000 nT has been subtracted for all values.

The magnetic relief on this grid is less than that of the other grids. The general trend in the southern and eastern parts of the grid is northerly. A north-easterly trend is observed in the northwest part of the grid.

There is a prominent linear trend in the southeast corner of the grid at 650E from Line 265 to Line 20S. The limited width of this anomaly and the higher gradient found in two other localized areas (Line 245 at 800W and Line 45 at 1350W) indicate that the general lack of magnetic activity is due to



the relatively homogenous nature of the magnetic properties of the underlying rock rather than to deep overburden.

4.3.2 VLF Survey

The contours of Fraser filtered VLF dip angles are shown on Plate 6. The contour interval is 10%.

The trend of the anomalies outlined by the contours of Fraser filtered VLF data is a uniform northerly direction on the entire grid. The north-easterly trend exhibited by the magnetic contours in the northern part of the grid is not evidenced in the VLF contours.

The conductor at 700E on Lines 26S, 24S and 20S is coincident with a magnetic anomaly in this area.

A localized VLF anomaly with a peak amplitude of 70% is coincident with an area of higher magnetic gradient on Line 4S at 1350W.

4.4 HOT GRID

4.4.1 Magnetic Survey

The contours of magnetic field intensity are shown in Plate 7. The contour interval is 100 nT and a value of 56000 nT has been subtracted from each value.

The general trend of the magnetic contours is northerly. With the exception of one area in the northwest, the pattern of the



magnetic contours is complex with high magnetic relief. The area north of Line 10N has a low magnetic relief.

4.4.2 VLF Survey

The contours of Fraser filtered VLF dip angles are shown on Plate 8. The contour interval is 10%. The trend of the VLF contours is generally in a north direction. However, this trend is approximately 20° East of the trend which is observed in the magnetic contours.

The peak amplitude of the Fraser filtered VLF anomalies range from poor to moderate. The highest amplitude anomaly has a peak amplitude of 60%. This anomaly which is located at 850E on Line 16S through Line 8S is coincident with a magnetic high.

The area north of Line 10N has few VLF anomalies. The anomalies that exist in this area are very weak. This is in agreement with the lack of magnetic relief in the same area.

5.0 SUMMARY

During the period from June to July 1984, a magnetic and VLF-EM survey were carried out on four grids in the Cariboo mining district in the vicinity of the town of Horsefly. The general trend of both the magnetic and VLF contours is in a northerly direction. East-west trends in the VLF survey



cannot be ruled out as features in this direction would be poorly coupled with the VLF transmitter used in the survey.

Respectfully submitted, -

HARDY ASSOCIATES (1978) LTD.

Frank K. Maxwell

Per:

F. Maxwell, Ph.D.
Senior Geophysicist

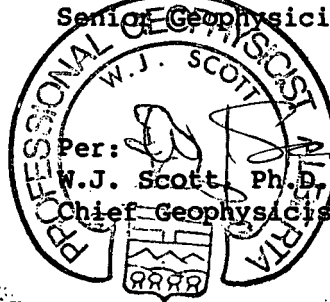

FM/bac



HARDY ASSOCIATES (1978) LTD.
CONSULTING ENGINEERING & PROFESSIONAL SERVICES

APPENDIX "A"

PRINCIPLES AND OPERATING PROCEDURE OF VLF INSTRUMENTS



APPENDIX "A"

The VLF stations operating for communications with submarines transmit in the frequency range from 15 kHz to 25 kHz. The EM 16 is simply a sensitive receiver covering the frequency band of the VLF-transmitting stations.

The receiver has two inputs; one receiving coil has normally vertical axis and the other horizontal. The signal from both coils is first minimized by tilting the instrument so that the vertical axis coil is aligned with the total magnetic field. The tilt angle meter, calibrated in percentage, gives the tangent of the dip angle, from which the vertical component of the secondary magnetic field can be calculated. Any remaining signal in the tilted coil is due to the vertical quadrature component of the secondary magnetic field. The quadrature dial, which is calibrated in percent, is rotated to cancel out any remaining signal in the coil. The instrument gives the amplitude of the quadrature signal as a percent of the total magnetic field. Therefore if the vertical secondary field is small compared to the horizontal primary field, the mechanical tilt-angle is an accurate measure of the vertical real-component and the compensation indicated by the dial a measure of the vertical quadrature component. In this case the total field vector as shown in Figure 1a is comparable in length to the horizontal primary vector. However, if the vertical secondary field is large relative to the horizontal primary field then, as shown in Figure 1b, the measurement of the quadrature



signal as a percentage of the horizontal primary field is not accurate. A correction as a function of the tilt-angle is possible although unnecessary below an angle of approximately 17° (30%). For example, 17° would give an error of 4% on the quadrature measurement.

For optimum results from VLF-EM the horizontal axis coil should be aligned with the primary magnetic field which consists of concentric circles around the VLF transmitter. In this case the grid lines should be perpendicular to the azimuth of the transmitting station. Small deviations from 90° are tolerable and do not affect the results significantly.

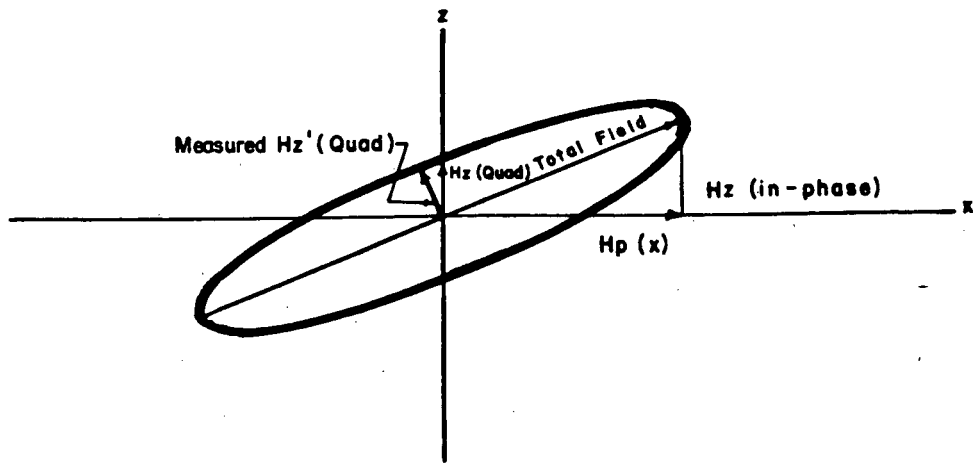

FIG. 1 a

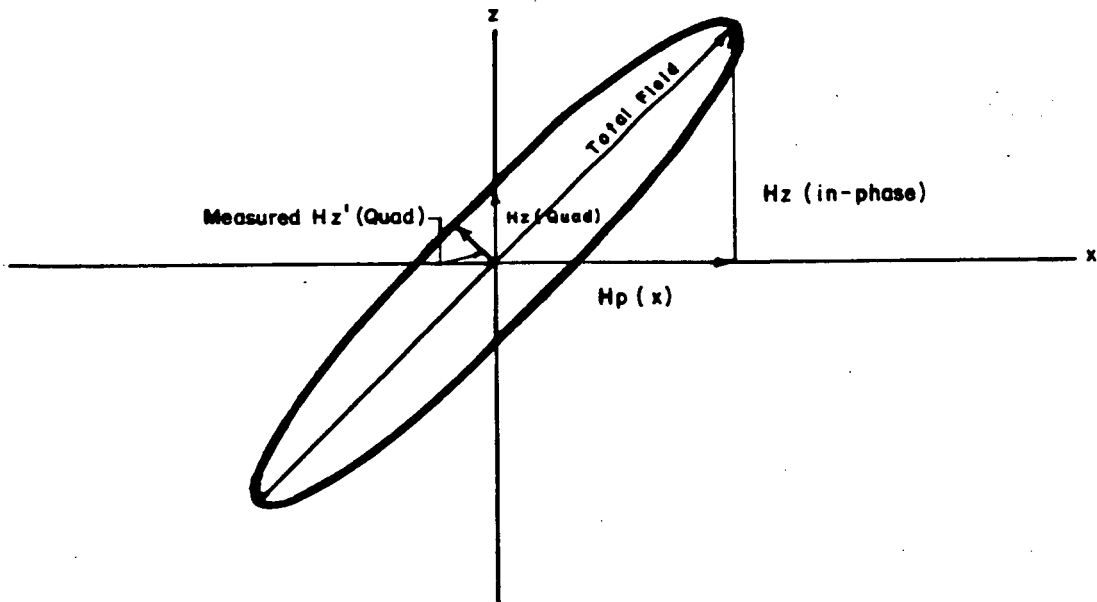

FIG. 1 b



HARDY ASSOCIATES (1979) LTD.
CONSULTING ENGINEERING & PROFESSIONAL SERVICES

1a For small Hz (in phase) $H_z' \text{ (Quad)} \approx H_z \text{ (Quad)}$
1b For large Hz (in phase) $H_z' \text{ (Quad)} \ll H_z \text{ (Quad)}$

Fig. 1

EM16

VLF Electromagnetic Unit

Pioneered and patented exclusively by Geonics Limited, the VLF method of electromagnetic surveying has been proven to be a major advance in exploration geophysical instrumentation.

Since the beginning of 1965 a large number of mining companies have found the EM16 system to meet the need for a simple, light and effective exploration tool for mining geophysics.

The VLF method uses the military and time standard VLF transmissions as primary field. Only a receiver is then used to measure the secondary fields radiating from the local conductive targets. This allows a very light, one-man instrument to do the job. Because of the almost uniform primary field, good response from deeper targets is obtained.

The EM16 system provides the *in-phase* and *quadrature* components of the secondary field *with the polarities indicated*.

Interpretation technique has been highly developed particularly to differentiate deeper targets from the many surface indications.

Principle of Operation

The VLF transmitters have vertical antennas. The magnetic signal component is then horizontal and concentric around the transmitter location.

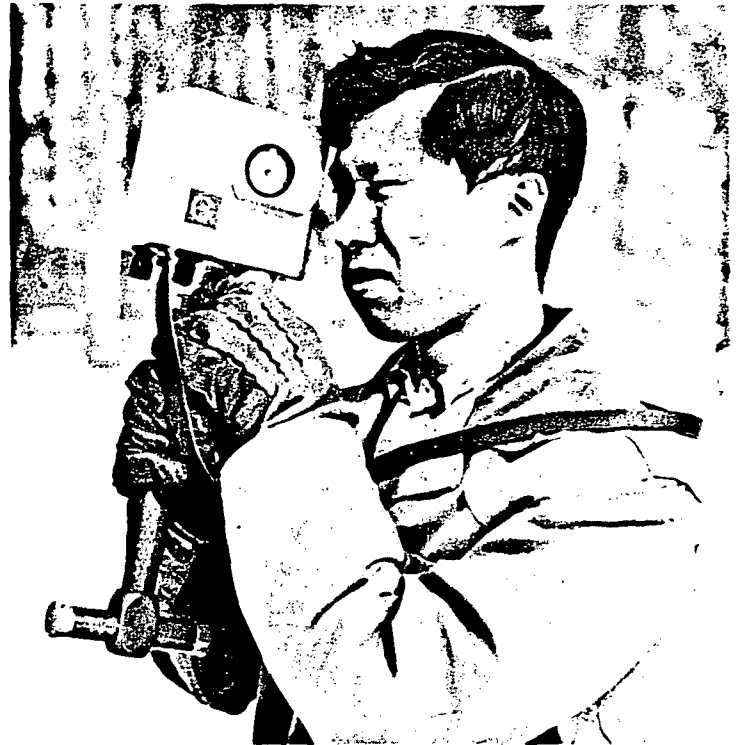

Specifications

Source of primary field	VLF transmitting stations.	Reading time	10-40 seconds depending on signal strength.
Transmitting stations used	Any desired station frequency can be supplied with the instrument in the form of plug-in tuning units. Two tuning units can be plugged in at one time. A switch selects either station.	Operating temperature range	-40 to 50° C.
Operating frequency range	About 15-25 kHz.	Operating controls	ON-OFF switch, battery testing push button, station selector, switch, volume control, quadrature, dial $\pm 40\%$, inclinometer dial $\pm 150\%$.
Parameters measured	(1) The vertical in-phase component (tangent of the tilt angle of the polarization ellipsoid). (2) The vertical out-of-phase (quadrature) component (the short axis of the polarization ellipsoid compared to the long axis).	Power Supply	6 size AA (penlight) alkaline cells. Life about 200 hours.
Method of reading	In-phase from a mechanical inclinometer and quadrature from a calibrated dial. Nulling by audio tone.	Dimensions	42 x 14 x 9 cm (16 x 5.5 x 3.5 in.)
Scale range	In-phase $\pm 150\%$; quadrature $\pm 40\%$.	Weight	1.6 kg (3.5 lbs.)
Readability	$\pm 1\%$.	Instrument supplied with	Monotonic speaker, carrying case, manual of operation, 3 station selector plug-in tuning units (additional frequencies are optional), set of batteries.
		Shipping weight	4.5 kg (10 lbs.)



GEONICS LIMITED

Designers & manufacturers
of geophysical instruments

2 Thorncliffe Park Drive
Toronto/Ontario/Canada
M4H 1H2
Tel: (416) 425-1821
Cables: Geonic's

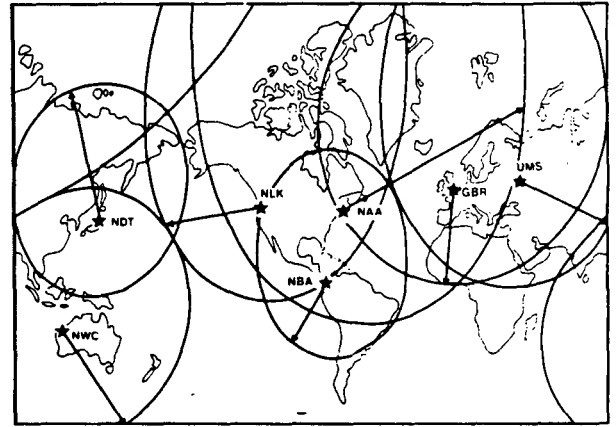
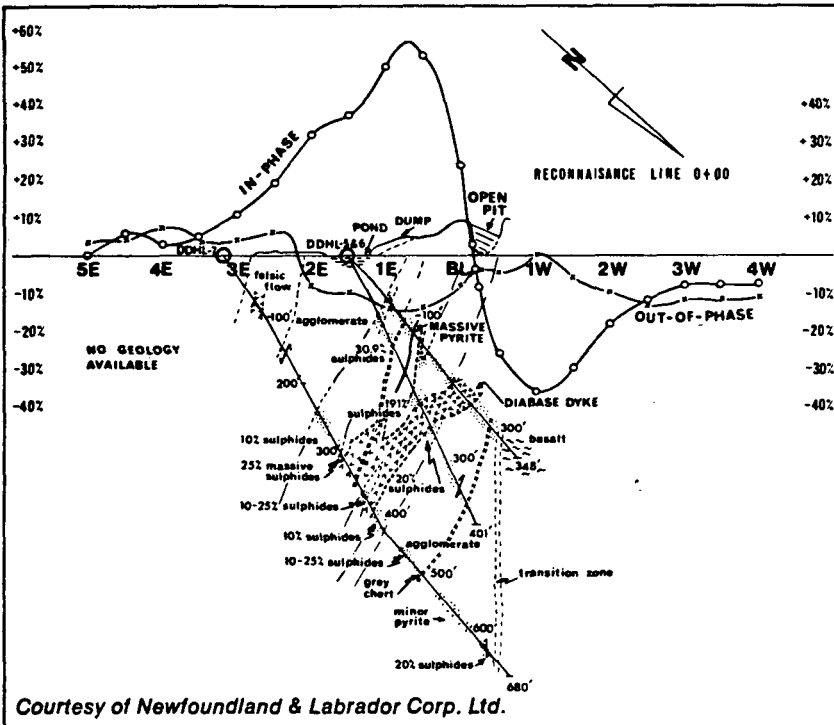

Areas of VLF Signals

Coverage shown only for well-known stations. Other reliable, fully operational stations exist. For full information regarding VLF signals in your area consult Geonics Limited. Extensive field experience has proved that the circles of coverage shown are very conservative and are actually much larger in extent.

EM 16 Profile over Lockport Mine Property, Newfoundland

Additional case histories on request.

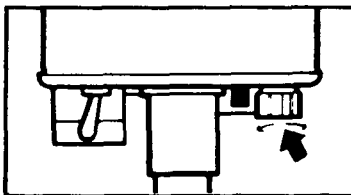

Station Selector
Two tuning units can be plugged in at one time. A switch selects either station.

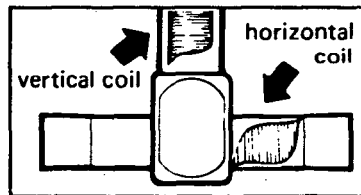

Receiving Coils
Vertical receiving coil circuit in instrument picks up any vertical signal present. Horizontal receiving coil circuit, after automatic 90° signal phase shift, feeds signal into quadrature dial in series with the receiving coil.

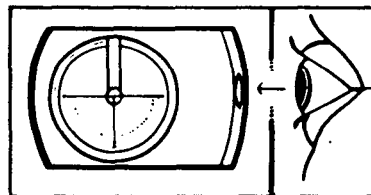

In-Phase Dial
Shows the tilt-angle of the instrument for minimum signal. This angle is the measure of the vertical in-phase signal expressed in percentage when compared to the horizontal field.

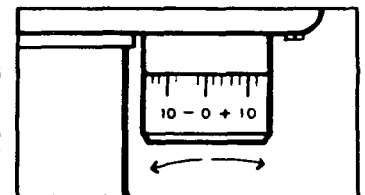

Quadrature Dial
is calibrated in percentage markings and nulls the vertical quadrature signal in the vertical coil circuit.

By selecting a suitable transmitter station as a source, the EM 16 user can survey with the most suitable primary field azimuth.

The EM 16 has two receiving coils, one for the pick-up of the horizontal (primary) field and the other for detecting any anomalous vertical secondary field. The coils are thus orthogonal, and are mounted inside the instrument "handle".

The actual measurement is done by first tilting the coil assembly to minimize the signal in the vertical (signal) coil and then further sharpening the null by using the reference signal to buck out the remaining signal. This is done by a calibrated "quadrature" dial.

The tangent of the tilt angle is the measure of the vertical in-phase component and the quadrature reading is the signal at right angles to the total field. All readings are obtained in percentages and do not depend on the absolute amplitude of the primary signals present.

The "null" condition of the measurement is detected by the drop in the audio signal emitted from the patented resonance loudspeaker. A jack is provided for those preferring the use of an earphone instead.

The power for the instrument is from 6 penlight cells. A battery tester is provided.



APPENDIX "B"

GENERATION OF VLF ANOMALIES



APPENDIX "B"

VLF anomalies can be generated in two ways, by inductive coupling or by current channeling. In the case of inductive coupling the primary VLF field interacts inductively with a local conductor to produce a local secondary electro-magnetic field which is seen as a perturbation in the primary field. Inductive coupling generates significant anomalies only when local structures have conductivity-thickness products of 1 mho or better.

The other way of generating VLF anomalies is known as current channeling. The remote transmitter may be thought of as a source with current flowing up into the sky, radiating out in all directions, and returning radially to the transmitter through the earth. If the earth is homogeneous, the return current density is uniform. However, if there are local zones in the earth that are lower in resistivity, then the return current will be channeled through these zones. The strike of these conductors relative to the azimuth of the exciting station is important. If the difference is close to zero then the maximum amount of current will be channeled through the conductor. For current channeling situations the amplitude of the anomaly due to a conductor is proportional to the cosine of the angle between the conductor strike and the exciting station azimuth. For example, if a conductor is 45° off the azimuth of the station then the anomaly amplitude is reduced to 70% of the possible maximum. This reduction is not serious for a strong anomaly. However,



in the case of a weaker anomaly the peak-to-peak response of the conductor could possibly be reduced into the noise level.

Figure 1 shows some generalized VLF profiles that can arise from different conductor configurations. Shown in Figure 1a is a typical crossover that arises from inductive coupling with a conductor. In this case the quadrature usually follows the shape of the inphase response, but can have the same or opposite sign. For a poorly conductive fault or shear zone the quadrature is usually weak, indicating that the VLF response is mostly a result of current channeling. In both cases the distance between the maximum positive and maximum negative readings on the tilt profile is comparable to the depth from the ground surface to the center of the conductor.

Figure 1b is an example of a VLF profile across a contact, with contrasting resistivities on either side. In this case the peak of the asymmetrically shaped inphase response is directly over the contact. The steeper slope of the profile is on the less-resistive side of the contact. The quadrature consists of a single-polarity response similar to the inphase, but with a sharp minimum directly over the contact. For increasing thicknesses of overburden over the contact, the total response of both the inphase and quadrature is reduced and local minimum of the quadrature is increased. For increasing resistivity contrast across the contact both inphase and quadrature responses increase.



Figure 1c shows a generalized VLF profile over a flat lying conductive body. The prominent feature of this type of response is the positive peak of the inphase at one end of the structure and a negative type of response in the presence of conductive sediments on the bottom of a lake.

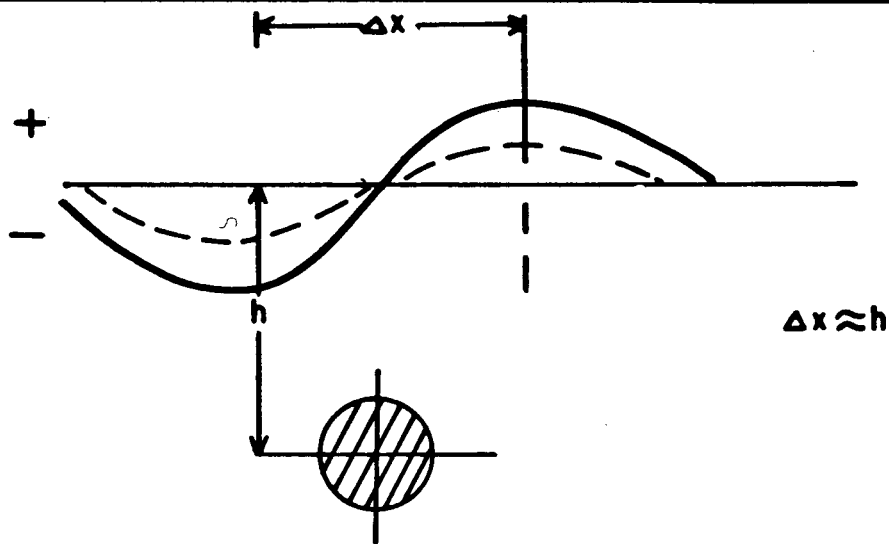

Fig. 1a

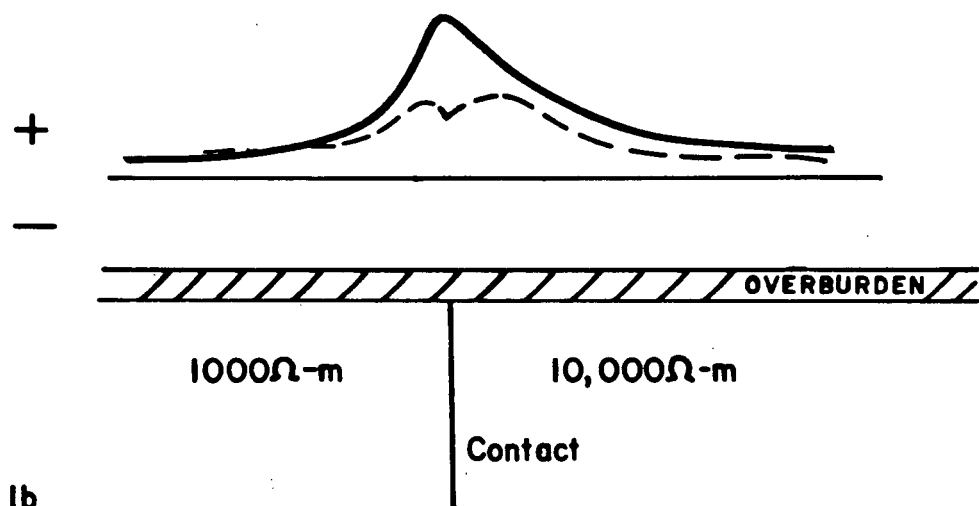

Fig. 1b

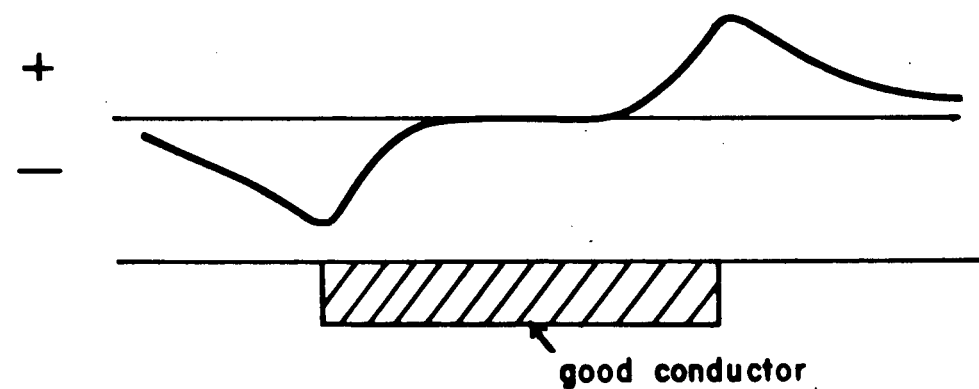

Fig. 1c

--- Quadrature
 ——— In-phase



HARDY ASSOCIATES (1978) LTD.
 CONSULTING ENGINEERING & PROFESSIONAL SERVICES

**SOME TYPICAL VLF PROFILES
 AND THEIR MODELS**

Fig. 1

OMNIMAG® PPM-375 Portable/Base Station Magnetometer

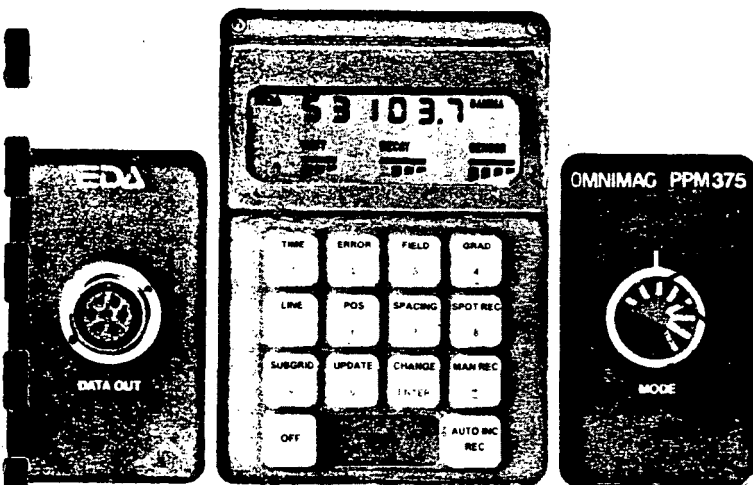

The PPM-375 is the most recent addition to EDA's OMNIMAG series of magnetometers and gradiometers. It combines features of EDA's PPM-350 Total Field Magnetometer and PPM-400 Base Station Magnetometer in one dual-purpose unit. This user oriented approach exemplifies EDA's pioneering efforts in the development of advanced geophysical systems.

This approach is another reason why EDA has shipped more microprocessor-based proton precession ground magnetometers in the highly competitive Canadian market than any other company in recent years.



As a portable field unit . . .

- Faster Surveys
- Simplified Fieldwork
- Highly Repeatable Data
- Easier Data Interpretation
- Computer Compatible



As a base station . . .

- Automatic Diurnal Corrections
- Programmable Base Field
- Automatic Base Field Calculations
- Calculates Differential Field Variations
- Programmable Cycling Interval
- Computer Compatible

OMNIMAG® PPM-375 Portable/Base Station Magnetometer

As a portable field unit...



the PPM-375 OMNIMAG is a portable proton precession survey magnetometer that measures and records in memory the earth's magnetic field at the touch of a key. It identifies and records the location, time of each measurement, computes the statistical error of the reading and records the decay and strength of

the signal being measured.

Features

Packaged in a compact, lightweight rugged housing, the PPM-375 provides:

- A visual readout and storage of the following information in an absolutely secure memory that prevents data loss or tampering:

- total field magnitude
- time of measurement
- grid coordinates for every reading
- direction of travel along grid lines
- statistical error of the total field reading
- signal strength and decay measurement

Users have a choice of three data storage modes:

- manual record
- spot record
- automatic update record

Each reading is automatically assigned a record number which can also be used to identify readings measured off the grid. This also serves to recall data, simply by entering the record number.

- More than one reading can be taken at one point without updating the current station number.
- Sub-grid coordinates and position update are given, permitting more detailed study within the main grid, without altering main grid data.

Major Benefits

Faster Surveys

Survey productivity is significantly increased with the PPM-375 because:

- a reading can be taken and stored in only 4 seconds
- a second reading is normally not required because the data is so repeatable
- the statistical error is calculated for each reading providing an indication of whether an additional reading may be required.

Using the PPM-375, operators have covered as much as 15km per day in ideal conditions.

Simplified Fieldwork

The PPM-375 solid state memory makes surveys easier to conduct because:

- the need to write down results is eliminated. Time, field reading, grid co-ordinates, etc., are simultaneously stored.
- diurnal corrections can be done automatically with the use of another PPM-375 or PPM-400 to eliminate 2-3 hours of tedious calculations.

Highly Repeatable Data

The PPM-375 provides users with repeatable data that significantly reduces the requirement for multiple station readings. Typical tie-line accuracies of ± 0.5 gammas are obtained.

This data quality is due to:

- a patented* Signal Processing Technique
- Constant Energy Polarization that maintains equal energy to the sensor
- processing sensitivity to ± 0.02 gamma
- Automatic Fine Tuning which uses the previous reading as the base for the next.

*the signal processing technique utilized in the OMNIMAG series is protected by patents granted in various countries.

Easier Data Interpretation

The PPM-375 makes geophysical interpretation easier because:

- more information such as statistical error, the signal strength and decay rate measurement is displayed and stored with every reading
- line profiles can be obtained immediately with portable field computers such as the HP-85 through available software.

Computer Compatible

All EDA OMNIMAG systems can be interfaced with many commercial computers which are compatible with RS-232C. This enables the operator to:

- obtain contour or other maps, immediately after the end of survey
- store permanently in the DCU-200 or field computer cassettes the data for further analysis.

Other Benefits

• Error Analysis

This unique feature is a great time saver because the calculation of the statistical error of each reading lets the operator make an on-the-spot decision whether that reading should be stored or not.

• Higher Gradient Tolerance

Higher tolerance to local gradients is possible due to a patented signal processing method and to a miniature sensor design utilizing a highly optimized sensor geometry.

• Complete Data Protection

Field data stored in memory is totally protected for 4 years by the lithium backup battery. This battery also provides power to the real-time clock.

• Data Recall

Daily readings can be recalled either by record number or in sequence.

• Power Supply Versatility

Users can choose from non-magnetic rechargeable sealed lead-acid battery cartridges or belts and disposable "C" cell battery cartridges or belts.

• Decimal Spacing

Intermediate readings can be stored every 12.5 units, while using the usual 25-unit station interval.



As a base station . . .



the PPM-375 OMNIMAG measures and stores in its memory the daily fluctuations of the earth's magnetic field. Used with other OMNIMAG units, the PPM-375 base

station corrects automatically, in just a few minutes, total field data for diurnal variations.

Features

- The PPM-375 OMNIMAG in the base station mode:
 - Automatically corrects magnetic field data for diurnal variations and base field values.
 - Records each base station value in the following format:
 - time of measurement
 - magnitude of total field
 - difference from the base field value
 - difference from the previous reading
 - sequential record number
 - Stores 2550 sets of readings, the equivalent to 10.6 hours of continuous unattended monitoring at 15-second sample interval.
 - Simultaneously outputs data to a choice of data collection units as it is being stored in memory.
 - Outputs data in a choice of three (3) formats:
 - corrected total field data
 - uncorrected total field data
 - base station data only

Major Benefits

Automatic Diurnal Corrections

The PPM-375 OMNIMAG Base Station corrects automatically the field data for diurnal variations when used with another PPM-375, with a PPM-350 or with a PPM-500 Vertical Gradiometer. A linear interpolation algorithm is used for corrections.

Programmable Base Field

Once the operator has identified the ideal base field value at the end of the first day, he can reprogram the base field and the PPM-375 will recalculate all stored readings with reference to the new base field.

Automatic Base Field Calculations

The PPM-375 calculates automatically for each reading the difference between the measured earth's field and the base field value previously entered in by the operator.

Calculates Differential Field Variations

The PPM-375 calculates automatically the difference between the current reading and the previous one, to 0.1 gamma.

Programmable Cycling Interval

The operator can have the PPM-375 cycle at any interval, in one second increments, from a minimum of 5 seconds to a maximum of 60 minutes.

Computer Compatible

All EDA OMNIMAG systems can be interfaced with many commercial computers which are compatible with RS-232C.

Other Benefits

- Stores & Prints Data Simultaneously**
The PPM-375 can record and print out data simultaneously. Printed data can still be retained in memory.
- Three Data Output Capabilities**
Linked with another OMNIMAG the PPM-375 provides a choice of 3 data formats as shown below.
- Power Supply Flexibility**
The PPM-375 Base Station can be operated from:
 - a 12 volt DC car battery
 - rechargeable sealed lead-acid battery cartridge or belt
 - disposable "C" cell battery cartridge or belt
- Versatile Charging Options**
The sealed lead-acid batteries can be recharged with:
 - a 12 volt DC car battery, through the DCU-400 Thermal Printer, or
 - any other AC power source
- Expanded Memory Capability**
The PPM-375 memory capability of 2550 sets of readings can be expanded to 11,475 readings when used with the DCU-200 Digital Magnetic Recorder.
- Internal Real Time Clock**
Real time clocks can be synchronized to the nearest second when using the PPM-375 with any other OMNIMAG unit.
- Environmental Dependability**
PPM-375 operates in temperature extremes of -40°C to +55°C. At -25°C, a heater is automatically activated to ensure LCD performance.

```

PPM300 #30023 B=75
08/04 15:00:39
OP #7
15:00:35 57508.4 .10 #1 88
15:00:43 57508.3 .08 #2 88
15:00:47 57508.0 .08 #3 88
15:00:51 57501.9 .10 G 5400 3250 #4 88
15:00:56 57504.1 .08 G 5400 3300A 88
15:01:00 57503.1 .07 G 5400 3350A 88
15:01:05 57511.1 .07 G 5400 3400A 88
15:01:09 57514.9 .09 G 5400 3450A 88
15:01:17 57511.1 .08 G 5400 3500A 88
  
```

PPM-375 Uncorrected Data

```

PPM400 #30078 B=73
08/04 14:54:14
OP #2
15:00:33 57500.0 0 0 77
15:00:38 57517.8 -0.4 17.8 77
15:00:43 57508.6 -0.2 8.6 78
15:00:47 57511.7 3.1 11.7 79
15:00:49 57510.5 -1.2 10.5 80
15:00:53 57518.0 7.5 18.0 81
15:00:58 57525.9 7.9 25.9 82
15:01:03 57514.8 -11.1 14.8 83
15:01:08 57508.4 -6.4 18.4 84
15:01:13 57512.9 4.0 12.9 85
15:01:18 57512.7 -0.2 12.7 86
  
```

PPM-375 Data in Base Station Mode

```

PPM300 #30023 B=75
08/04 15:00:39
OP #7
57514.1 -5.7 .10 0 #1 88
57511.7 -5.4 .08 #2 88
57510.7 -5.7 .08 #3 88
57515.0 -13.1 .10 5400 3250 #4 88
57522.7 -18.6 .08 5400 3300A 88
57521.5 -18.4 .07 5400 3350A 88
57512.2 -11.1 .07 5400 3400A 88
57509.3 5.6 .09 5400 3450A 88
57512.7 -1.6 .08 5400 3500A 88
  
```

Corrected Data Output Format: Corrected total field reading; applied drift direction; statistical error; line & position numbers; recording mode; normalized decay rate and amplitude of sensor signal.

Specifications

Dynamic Range	18,000 to 103,000 gammas
Capture Range	±25% relative to ambient field strength of last stored value
Tuning Method	Tuning value is calculated accurately utilizing a specially developed tuning algorithm.
Display Resolution	0.1 gamma.
Processing Sensitivity	±0.02 gamma.
Mathematical Truncation Error	±0.02 gamma.
Statistical Error Resolution	0.01 gamma.
Absolute Accuracy	±15 ppm at 23°C, 50 ppm over the operating temperature range.
Standard Memory Capacity	2550 data blocks or readings
Display	Custom-designed, ruggedized liquid crystal display with an operating temperature range from -40°C to +55°C. The display contains six numeric digits, decimal point, battery status monitor, signal decay rate and signal amplitude monitor and function descriptors.
Gradient Tolerance	5,000 gammas per meter (typical).
Test Mode	A) Diagnostic testing (data and program-mable memory) B) Self Test (hardware)
Sensor	Optimized miniature design. Magnetic cleanliness is consistent with the specified absolute accuracy.
Sensor Cable	Remains flexible in temperature range specified; includes strain-relief connector.
Cycling Time (Base Station Mode)	Programmable from 5 seconds up to 60 minutes in 1 second increments
Operating Environmental Range	-40°C to +55°C; 0-100% relative humidity; weatherproof.
Power Supply	Non-magnetic rechargeable sealed lead-acid battery cartridge or belt; or Disposable "C" cell battery cartridge or belt; or 12V DC power source option for base station operation.
Battery Cartridge/Belt Life	2,000 to 5,000 readings, depending upon ambient temperature and rate of readings.
Weight and Dimensions	
Instrument Console only	3.4kg, 238 × 150 × 250mm
Lead-Acid Battery Cartridge	1.9kg, 235 × 105 × 90mm
Sensor	1.2kg, 56mm diameter × 200mm
System Complement	Instrument console; sensor; 3-meter cable, 30-meter cable for base station (for sales only), aluminum sectional sensor staff, power supply, harness assembly, operations manual.

The OMNIMAG PPM-375 interfaces with a variety of data collection units, including . . .

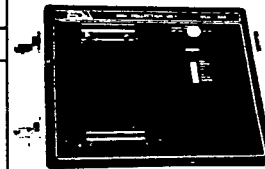

DCU-200 Digital Magnetic Recorder, AC and internal DC operation.

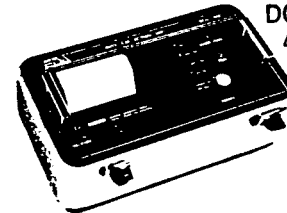

DCU-400 40-Character Thermal Printer, AC and internal/external DC operation.

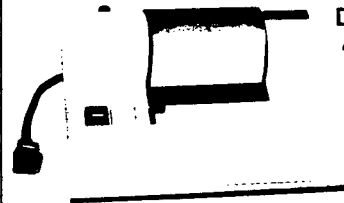

DCU-040 40-Character Thermal Printer, AC operation only.

EDA Instruments Inc.
1 Thorncliffe Park Drive
Toronto, Ontario
Canada M4H 1G9
Telex: 06 23222 EDA TOR
Cable: Instruments Toronto
(416) 425-7800

In U.S.A.
EDA Instruments Inc.
5151 Ward Road
Wheat Ridge, Colorado
U.S.A. 80033
Telex: 00 450681 DVR
(303) 422-9112

®OMNIMAG is a registered trademark of EDA Instruments Inc.

OMNIMAG PPM-350 Total Field Magnetometer

EDA



The PPM-350 is the latest addition to EDA's OMNIMAG*™ series of magnetometers and gradiometers. It is engineered to provide users with the latest state-of-the-art advances in microprocessor technology, including many features that are unique in the field.

Major benefits and features include:

- Significant increase in productivity
- Lowered survey costs
- Automatic diurnal correction
- Programmable grid coordinates
- Highly reproduceable data
- Ergonomic design
- Simplified fieldwork
- Computer-compatible

OMNIMAG PPM-350 Total Field Magnetometer

Description

The EDA OMNIMAG PPM-350 is a high-technology, proton precession total field magnetometer that measures and records the earth's magnetic field at the simple touch of a key. It identifies and records the location, time of each measurement, computes the statistical error, and records the decay and strength of the signal being measured.

The PPM-350 is a microprocessor-based system and employs a memory magnetometer concept pioneered by EDA.

Packaged in a compact, lightweight, rugged housing, the PPM-350 incorporates ergonomic-design features that provide maximum comfort and ease-of-operation in the field. It is used in a chest-mounted mode with a shoulder-harness. It has a large Liquid Crystal Display for easy reading, even in direct sunlight, and its oversized touch-sensitive keyboard permits cold-weather operation without having to remove gloves.



Functions

In a typical field survey operation, the PPM-350 can perform all of the following functions:

- A visual readout and storage of the following information *in an absolutely secure memory that prevents data loss or tampering*:
 - total magnetic field magnitude
 - time of measurement
 - grid coordinates for every reading
 - statistical error of total field reading
 - signal strength and decay measurement
- Users have a choice of three *input*, or data storage, modes:
 - manual record
 - spot record
 - automatic update record
- Users also have a choice of three *output* modes:
 - to a DCU-200 magnetic cassette recorder
 - to a DCU-040 or DCU-400 thermal printer
 - to any RS-232C-compatible microcomputer
- Each reading is automatically assigned a record number which can also be used to identify locations of measurements taken off the grid. This also serves to recall data, as well, simply by keying in the record number.
- Sub-grid coordinates and position up-date are given, permitting more detailed study within the main grid, without altering main grid data.
- Many readings can be taken at one point to verify a reading, without updating the position.

Features and Benefits

Productivity Up, Costs Down

Users of the OMNIMAG PPM-350 can enjoy increases in survey productivity by as much as 50% because of the solid-state features that are designed into it. This increase in productivity, with resultant lower survey costs, is made possible because it enables the operator to take measurements faster and with greater accuracy than conventional techniques permit. This, in turn, allows the survey operator to spend more time in the field surveying significantly more area than would be otherwise possible.



Automatic Diurnal Correction

Diurnal variations are corrected automatically and in just a few minutes, instead of the two or three hours required in manual operation. The raw total field data collected and stored in the PPM-350 is corrected by the PPM-400 Base Station Magnetometer through a single cable link. Using the linear interpolation method, corrected data is produced faster and more accurately, because the possibility of human error is reduced.

Programmable Grid Coordinates

Measurements are also made faster and more accurately because the location of each reading is taken automatically on an incremental basis, and recorded along with the time of that measurement. An additional benefit of this feature is that it can provide the basis for computer plotting to obtain survey profiles.

Highly Reproduceable Data

The PPM-350 provides users with the highest confidence level in the

Other Features

industry. Its highly reproduceable data is a result of four leading-edge design features that eliminate the need for taking multiple readings:

- An exclusive Signal Processing Technique*
- Constant Energy Polarization that maintains equal energy to the sensor even when the main battery supply decreases
- Sensitivity to ± 0.02 gamma that ensures repeatability of readings
- Automatic Fine-Tuning that takes the previous reading as the base for the next

Ergonomic Design

Operator comfort and efficiency were prime considerations in the design of the new PPM-350. It is lightweight and is encased in a rugged housing that permits operation in a wide variety of field conditions. The oversize keyboard enables the operator to take measurements without removing gloves. Large LCD's make reading much easier, even in bright sunlight.

Fieldwork Simplified

Since each reading is automatically stored in a non-volatile memory, the need to make handwritten notebook entries on total field magnitude, time of reading, line and station numbers, etc. is eliminated. This reduces the need for notebook usage by the operator, thereby improving productivity. Also, it allows field surveys to be made under all weather conditions.

Computer Compatible

All EDA OMNIMAG systems can interface with any computer using RS-232C standard. This enables generation of profiles, contour maps, etc.

- **Data Recall.** Daily readings can be recalled either by record number or in sequence.
- **Non-Volatile Memory.** A lithium battery with a life-expectancy of 4 years provides total protection of data stored in memory and of the real-time clock in case the primary battery runs down or is removed.
- **Environmental Dependability.** PPM-350 operates in temperature extremes of -35°C to 55°C . At -25°C , a heater automatically activates to ensure LCD performance. Environmental sealing allows operation in very high humidity and in driving rain.
- **Higher Gradient Tolerance.** More accurate readings are obtained because the PPM-350's optimized sensor geometry and reduced size result in higher tolerances to local gradients.
- **Power Supply Versatility.** Users can choose from a variety of power packages:
 - rechargeable sealed lead acid battery belt or cartridge
 - disposable alkaline "C" cell battery belt or cartridge.
- **Error Analysis.** This unique feature is a great time saver because the calculation of the statistical error of each reading lets the operator make an on-the-spot decision whether that reading should be stored or not.
- **Memory Upgrade.** The standard memory of 1383 readings is optionally expandable up to 2555 readings.
- **Decimal Spacing.** Intermediate readings can be stored every 12.5 units, while using the usual 25-unit station interval.
- **Internal Real-Time Clock.** More accurate and reliable measurements can be made and stored because time is taken to the nearest second. Also, the operator need not wear a wrist-watch, which is a common and often overlooked source of magnetic interference.

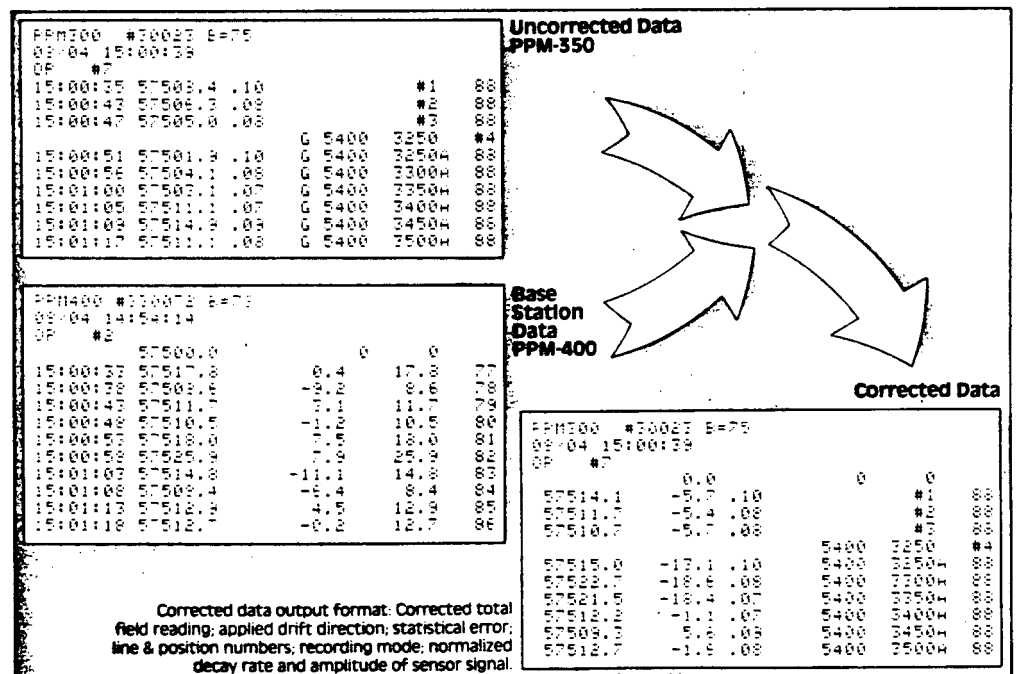

*Patent Pending



Specifications

Dynamic Range	18,000 to 93,000 gammas
Sensitivity	± 0.02 gamma
Statistical Error Resolution	0.01 gamma
Standard Memory Capacity	1383 data blocks or readings
Absolute Accuracy	± 15 ppm at 23°C, 50 ppm over the operating temperature range
Display Resolution	0.1 gamma
Capture Range	$\pm 25\%$ relative to ambient field strength of last stored value
Display	Custom-designed, ruggedized liquid crystal display with an operating temperature range from -35°C to $+55^{\circ}\text{C}$
Gradient Tolerance	5,000 gammas per meter
Sensor	Optimized miniature design. Magnetic cleanliness is consistent with the specified absolute accuracy
Sensor Cable	Remains flexible in temperature range; includes low strain connector
Operating Environmental Range	-35°C to $+55^{\circ}\text{C}$; 0-100% relative humidity; weather-proof
Power Supply	Non-magnetic rechargeable sealed lead acid battery cartridge or belt; or, Disposable "C" cell battery cartridge or belt
Battery Cartridge Life	2,000 to 5,000 readings, depending upon ambient temperature and rate of readings
Weight and Dimensions	
Instrument Console only	3.4 kg, 238 x 150 x 250 mm
Lead Acid Battery Cartridge	1.9 kg
Sensor	1.2 kg, 56 mm diameter x 200 mm
System Complement	Electronics console; sensor with 3-meter cable; sensor staff; power supply; harness assembly; operation manual.

EDA is a pioneer in the development of advanced geophysical systems and has created many innovations that increase field productivity and lower survey costs.

EDA's OMNIMAG series consists of the PPM-350 Total Field Magnetometer, PPM-400 Base Station Magnetometer, and the PPM-500 Vertical Gradiometer. Contact us **now** for details.

EDA Instruments Inc.
1 Thorncliffe Park Drive
Toronto, Ontario
Canada M4H 1G9
Telex: 06 23222 EDA TOR
Cable: Instruments Toronto
(416) 425-7800

In U.S.A.
EDA Instruments Inc.
5151 Ward Road
Wheat Ridge, Colorado
U.S.A. 80033
Telex: 00 450681 DVR
(303) 422-9112

OMNIMAG® PPM-375 Portable/Base Station Magnetometer

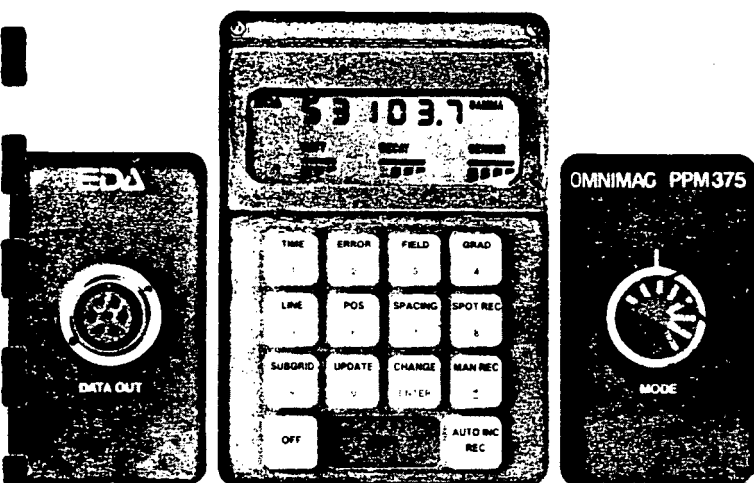

The PPM-375 is the most recent addition to EDA's OMNIMAG series of magnetometers and gradiometers. It combines features of EDA's PPM-350 Total Field Magnetometer and PPM-400 Base Station Magnetometer in one dual-purpose unit. This user oriented approach exemplifies EDA's pioneering efforts in the development of advanced geophysical systems.

This approach is another reason why EDA has shipped more microprocessor-based proton precession ground magnetometers in the highly competitive Canadian market than any other company in recent years.



As a portable field unit . . .

- Faster Surveys
- Simplified Fieldwork
- Highly Repeatable Data
- Easier Data Interpretation
- Computer Compatible

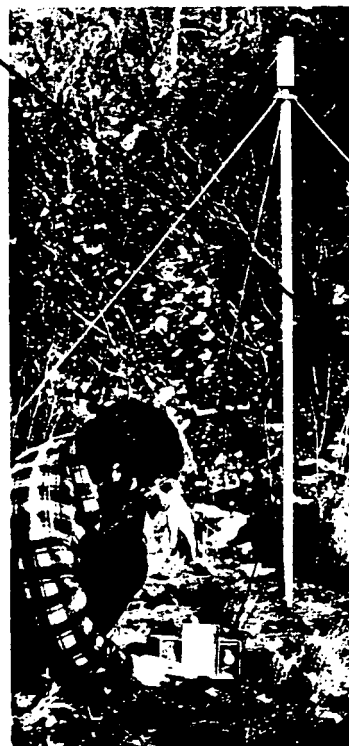

As a base station . . .

- Automatic Diurnal Corrections
- Programmable Base Field
- Automatic Base Field Calculations
- Calculates Differential Field Variations
- Programmable Cycling Interval
- Computer Compatible

OMNIMAG® PPM-375

Portable/Base Station Magnetometer

As a portable field unit...



the PPM-375 OMNIMAG is a portable proton precession survey magnetometer that measures and records in memory the earth's magnetic field at the touch of a key. It identifies and records the location, time of each measurement, computes the statistical error of the reading and records the decay and strength of

the signal being measured.

Features

Packaged in a compact, lightweight rugged housing, the PPM-375 provides:

- A visual readout and storage of the following information in an absolutely secure memory that prevents data loss or tampering:

- total field magnitude
- time of measurement
- grid coordinates for every reading
- direction of travel along grid lines
- statistical error of the total field reading
- signal strength and decay measurement

Users have a choice of three data storage modes:

- manual record
- spot record
- automatic update record

Each reading is automatically assigned a record number which can also be used to identify readings measured off the grid. This also serves to recall data, simply by entering the record number.

- More than one reading can be taken at one point without updating the current station number.
- Sub-grid coordinates and position update are given, permitting more detailed study within the main grid, without altering main grid data.

Major Benefits

Faster Surveys

Survey productivity is significantly increased with the PPM-375 because:

- a reading can be taken and stored in only 4 seconds
- a second reading is normally not required because the data is so repeatable
- the statistical error is calculated for each reading providing an indication of whether an additional reading may be required.

Using the PPM-375, operators have covered as much as 15km per day in ideal conditions.

Simplified Fieldwork

The PPM-375 solid state memory makes surveys easier to conduct because:

- the need to write down results is eliminated. Time, field reading, grid co-ordinates, etc., are simultaneously stored.
- diurnal corrections can be done automatically with the use of another PPM-375 or PPM-400 to eliminate 2-3 hours of tedious calculations.

Highly Repeatable Data

The PPM-375 provides users with repeatable data that significantly reduces the requirement for multiple station readings. Typical tie-line accuracies of ± 0.5 gammas are obtained.

This data quality is due to:

- a patented* Signal Processing Technique
- Constant Energy Polarization that maintains equal energy to the sensor
- processing sensitivity to ± 0.02 gamma
- Automatic Fine Tuning which uses the previous reading as the base for the next.

*the signal processing technique utilized in the OMNIMAG series is protected by patents granted in various countries.

Easier Data Interpretation

The PPM-375 makes geophysical interpretation easier because:

- more information such as statistical error, the signal strength and decay rate measurement is displayed and stored with every reading
- line profiles can be obtained immediately with portable field computers such as the HP-85 through available software.

Computer Compatible

All EDA OMNIMAG systems can be interfaced with many commercial computers which are compatible with RS-232C. This enables the operator to:

- obtain contour or other maps, immediately after the end of survey
- store permanently in the DCU-200 or field computer cassettes the data for further analysis.

Other Benefits

• Error Analysis

This unique feature is a great time saver because the calculation of the statistical error of each reading lets the operator make an on-the-spot decision whether that reading should be stored or not.

• Higher Gradient Tolerance

Higher tolerance to local gradients is possible due to a patented signal processing method and to a miniature sensor design utilizing a highly optimized sensor geometry.

• Complete Data Protection

Field data stored in memory is totally protected for 4 years by the lithium backup battery. This battery also provides power to the real-time clock.

• Data Recall

Daily readings can be recalled either by record number or in sequence.

• Power Supply Versatility

Users can choose from non-magnetic rechargeable sealed lead-acid battery cartridges or belts and disposable "C" cell battery cartridges or belts.

• Decimal Spacing

Intermediate readings can be stored every 12.5 units, while using the usual 25-unit station interval.

As a base station . . .



the PPM-375 OMNIMAG measures and stores in its memory the daily fluctuations of the earth's magnetic field. Used with other OMNIMAG units, the PPM-375 base

station corrects automatically, in just a few minutes, total field data for diurnal variations.

Features

The PPM-375 OMNIMAG in the base station mode:

- Automatically corrects magnetic field data for diurnal variations and base field values.
- Records each base station value in the following format:
 - time of measurement
 - magnitude of total field
 - difference from the base field value
 - difference from the previous reading
 - sequential record number
- Stores 2550 sets of readings, the equivalent to 10.6 hours of continuous unattended monitoring at 15-second sample interval.
- Simultaneously outputs data to a choice of data collection units as it is being stored in memory. Outputs data in a choice of three (3) formats:
 - corrected total field data
 - uncorrected total field data
 - base station data only

Major Benefits

Automatic Diurnal Corrections

The PPM-375 OMNIMAG Base Station corrects automatically the field data for diurnal variations when used with another PPM-375, with a PPM-350 or with a PPM-500 Vertical Gradiometer. A linear interpolation algorithm is used for corrections.

Programmable Base Field

Once the operator has identified the ideal base field value at the end of the first day, he can reprogram the base field and the PPM-375 will recalculate all stored readings with reference to the new base field.

Automatic Base Field Calculations

The PPM-375 calculates automatically for each reading the difference between the measured earth's field and the base field value previously entered in by the operator.

Calculates Differential Field Variations

The PPM-375 calculates automatically the difference between the current reading and the previous one, to 0.1 gamma.

Programmable Cycling Interval

The operator can have the PPM-375 cycle at any interval, in one second increments, from a minimum of 5 seconds to a maximum of 60 minutes.

Computer Compatible

All EDA OMNIMAG systems can be interfaced with many commercial computers which are compatible with RS-232C.

Other Benefits

• Stores & Prints Data Simultaneously

The PPM-375 can record and print out data simultaneously. Printed data can still be retained in memory.

• Three Data Output Capabilities

Linked with another OMNIMAG the PPM-375 provides a choice of 3 data formats as shown below.

• Power Supply Flexibility

The PPM-375 Base Station can be operated from:

- a 12 volt DC car battery
- rechargeable sealed lead-acid battery cartridge or belt
- disposable "C" cell battery cartridge or belt

• Versatile Charging Options

The sealed lead-acid batteries can be recharged with:

- a 12 volt DC car battery, through the DCU-400 Thermal Printer, or
- any other AC power source

• Expanded Memory Capability

The PPM-375 memory capability of 2550 sets of readings can be expanded to 11,475 readings when used with the DCU-200 Digital Magnetic Recorder.

• Internal Real Time Clock

Real time clocks can be synchronized to the nearest second when using the PPM-375 with any other OMNIMAG unit.

• Environmental Dependability

PPM-375 operates in temperature extremes of -40°C to +55°C. At -25°C, a heater is automatically activated to ensure LCD performance.

```

PPM300 #30023 B=75
08/04 15:00:39
OP #7
15:00:35 57508.4 .10 #1 88
15:00:43 57508.3 .08 #2 88
15:00:47 57505.0 .08 #3 88
15:00:51 57501.9 .10 G 5400 3250 #4
15:00:56 57504.1 .08 G 5400 3250A 88
15:01:00 57503.1 .07 G 5400 3300A 88
15:01:05 57511.1 .07 G 5400 3400A 88
15:01:09 57514.9 .03 G 5400 3450A 88
15:01:17 57511.1 .08 G 5400 3500A 88
    
```

PPM-375 Uncorrected Data

```

PPM400 #330072 B=75
08/04 14:54:14
OP #2
15:00:33 57500.0 0 0 77
15:00:38 57517.8 0.4 17.8 77
15:00:38 57508.6 -9.2 8.6 78
15:00:43 57511.7 3.1 11.7 79
15:00:48 57518.5 -1.2 10.5 80
15:00:53 57518.0 7.5 18.0 81
15:00:58 57525.9 7.9 25.9 82
15:01:03 57514.8 -11.1 14.8 83
15:01:08 57508.4 -6.4 8.4 84
15:01:13 57512.9 4.5 12.9 85
15:01:18 57512.7 -0.2 12.7 86
    
```

PPM-375 Data in Base Station Mode

```

PPM300 #30023 B=75
08/04 15:00:39
OP #7
57514.1 -5.7 .10 0 #1 88
57511.7 -5.4 .08 #2 88
57510.7 -5.7 .08 #3 88
57515.0 -13.1 .10 5400 3250 #4
57522.7 -18.6 .08 5400 3250A 88
57521.5 -18.4 .07 5400 3300A 88
57512.8 -1.1 .07 5400 3400A 88
57509.3 5.6 .03 5400 3450A 88
57512.7 -1.6 .08 5400 3500A 88
    
```

Corrected Data Output Format: Corrected total field reading; applied drift direction; statistical error; line & position numbers; recording mode; normalized decay rate and amplitude of sensor signal.



Specifications

Dynamic Range	18,000 to 103,000 gammas
Capture Range	± 25% relative to ambient field strength of last stored value
Tuning Method	Tuning value is calculated accurately utilizing a specially developed tuning algorithm.
Display Resolution	0.1 gamma.
Processing Sensitivity	± 0.02 gamma.
Mathematical Truncation Error	± 0.02 gamma.
Statistical Error Resolution	0.01 gamma.
Absolute Accuracy	± 15 ppm at 23°C, 50 ppm over the operating temperature range.
Standard Memory Capacity	2550 data blocks or readings
Display	Custom-designed, ruggedized liquid crystal display with an operating temperature range from -40°C to +55°C. The display contains six numeric digits, decimal point, battery status monitor, signal decay rate and signal amplitude monitor and function descriptors.
Gradient Tolerance	5,000 gammas per meter (typical).
Test Mode	A) Diagnostic testing (data and program-mable memory) B) Self Test (hardware)
Sensor	Optimized miniature design. Magnetic cleanliness is consistent with the specified absolute accuracy.
Sensor Cable	Remains flexible in temperature range specified; includes strain-relief connector.
Cycling Time (Base Station Mode)	Programmable from 5 seconds up to 60 minutes in 1 second increments
Operating Environmental Range	-40°C to +55°C; 0-100% relative humidity; weatherproof.
Power Supply	Non-magnetic rechargeable sealed lead-acid battery cartridge or belt; or Disposable "C" cell battery cartridge or belt; or 12V DC power source option for base station operation.
Battery Cartridge/Belt Life	2,000 to 5,000 readings, depending upon ambient temperature and rate of readings.
Weight and Dimensions	
Instrument Console only	3.4kg, 238 × 150 × 250mm
Lead-Acid Battery Cartridge	1.9kg, 235 × 105 × 90mm
Sensor	1.2kg, 56mm diameter × 200mm
System Complement	Instrument console; sensor; 3-meter cable, 30-meter cable for base station (for sales only), aluminum sectional sensor staff, power supply, harness assembly, operations manual.

The OMNIMAG PPM-375 interfaces with a variety of data collection units, including . . .

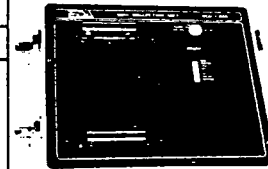

DCU-200 Digital Magnetic Recorder, AC and internal DC operation.

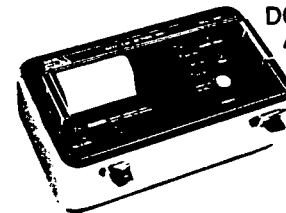

DCU-400 40-Character Thermal Printer, AC and internal/external DC operation.

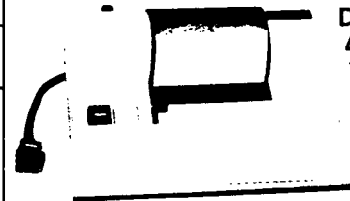

DCU-040 40-Character Thermal Printer, AC operation only.

EDA Instruments Inc.
1 Thorncliffe Park Drive
Toronto, Ontario
Canada M4H 1G9
Telex: 06 23222 EDA TOR
Cable: Instruments Toronto
(416) 425-7800

In U.S.A.
EDA Instruments Inc.
5151 Ward Road
Wheat Ridge, Colorado
U.S.A. 80033
Telex: 00 450681 DVR
(303) 422-9112

®OMNIMAG is a registered trademark of EDA Instruments Inc.

OMNIMAG PPM-350 Total Field Magnetometer

EDA



The PPM-350 is the latest addition to EDA's OMNIMAG*™ series of magnetometers and gradiometers. It is engineered to provide users with the latest state-of-the-art advances in microprocessor technology, including many features that are unique in the field.

Major benefits and features include:

- Significant increase in productivity
- Lowered survey costs
- Automatic diurnal correction
- Programmable grid coordinates
- Highly reproduceable data
- Ergonomic design
- Simplified fieldwork
- Computer-compatible

OMNIMAG PPM-350 Total Field Magnetometer

Description

The EDA OMNIMAG PPM-350 is a high-technology, proton precession total field magnetometer that measures and records the earth's magnetic field at the simple touch of a key. It identifies and records the location, time of each measurement, computes the statistical error, and records the decay and strength of the signal being measured.

The PPM-350 is a microprocessor-based system and employs a memory magnetometer concept pioneered by EDA.

Packaged in a compact, lightweight, rugged housing, the PPM-350 incorporates ergonomic-design features that provide maximum comfort and ease-of-operation in the field. It is used in a chest-mounted mode with a shoulder-harness. It has a large Liquid Crystal Display for easy reading, even in direct sunlight, and its oversized touch-sensitive keyboard permits cold-weather operation without having to remove gloves.



Functions

In a typical field survey operation, the PPM-350 can perform all of the following functions:

- A visual readout and storage of the following information *in an absolutely secure memory that prevents data loss or tampering*:
 - total magnetic field magnitude
 - time of measurement
 - grid coordinates for every reading
 - statistical error of total field reading
 - signal strength and decay measurement
- Users have a choice of three *input*, or data storage, modes:
 - manual record
 - spot record
 - automatic update record
- Users also have a choice of three *output* modes:
 - to a DCU-200 magnetic cassette recorder
 - to a DCU-040 or DCU-400 thermal printer
 - to any RS-232C-compatible microcomputer
- Each reading is automatically assigned a record number which can also be used to identify locations of measurements taken off the grid. This also serves to recall data, as well, simply by keying in the record number.
- Sub-grid coordinates and position up-date are given, permitting more detailed study within the main grid, without altering main grid data.
- Many readings can be taken at one point to verify a reading, without updating the position.

Features and Benefits

Productivity Up, Costs Down



Users of the OMNIMAG PPM-350 can enjoy increases in survey productivity by as much as 50% because of the solid-state features that are designed into it. This increase in productivity, with resultant lower survey costs, is made possible because it enables the operator to take measurements faster and with greater accuracy than conventional techniques permit. This, in turn, allows the survey operator to spend more time in the field surveying significantly more area than would be otherwise possible.

Automatic Diurnal Correction

Diurnal variations are corrected automatically and in just a few minutes, instead of the two or three hours required in manual operation. The raw total field data collected and stored in the PPM-350 is corrected by the PPM-400 Base Station Magnetometer through a single cable link. Using the linear interpolation method, corrected data is produced faster and more accurately, because the possibility of human error is reduced.

Programmable Grid Coordinates

Measurements are also made faster and more accurately because the location of each reading is taken automatically on an incremental basis, and recorded along with the time of that measurement. An additional benefit of this feature is that it can provide the basis for computer plotting to obtain survey profiles.

Highly Reproduceable Data

The PPM-350 provides users with the highest confidence level in the

Other Features

Industry. Its highly reproducible data is a result of four leading-edge design features that eliminate the need for taking multiple readings:

- An exclusive Signal Processing Technique*
- Constant Energy Polarization that maintains equal energy to the sensor even when the main battery supply decreases
- Sensitivity to ± 0.02 gamma that ensures repeatability of readings
- Automatic Fine-Tuning that takes the previous reading as the base for the next

Ergonomic Design

Operator comfort and efficiency were prime considerations in the design of the new PPM-350. It is lightweight and is encased in a rugged housing that permits operation in a wide variety of field conditions. The oversize keyboard enables the operator to take measurements without removing gloves. Large LCD's make reading much easier, even in bright sunlight.

Fieldwork Simplified

Since each reading is automatically stored in a non-volatile memory, the need to make handwritten notebook entries on total field magnitude, time of reading, line and station numbers, etc. is eliminated. This reduces the need for notebook usage by the operator, thereby improving productivity. Also, it allows field surveys to be made under all weather conditions.

Computer Compatible

All EDA OMNIMAG systems can interface with any computer using RS-232C standard. This enables generation of profiles, contour maps, etc.

- **Data Recall.** Daily readings can be recalled either by record number or in sequence.
- **Non-Volatile Memory.** A lithium battery with a life-expectancy of 4 years provides total protection of data stored in memory and of the real-time clock in case the primary battery runs down or is removed.
- **Environmental Dependability.** PPM-350 operates in temperature extremes of -35°C to 55°C . At -25°C , a heater automatically activates to ensure LCD performance. Environmental sealing allows operation in very high humidity and in driving rain.
- **Higher Gradient Tolerance.** More accurate readings are obtained because the PPM-350's optimized sensor geometry and reduced size result in higher tolerances to local gradients.
- **Power Supply Versatility.** Users can choose from a variety of power packages:
 - rechargeable sealed lead acid
 - battery belt or cartridge
 - disposable alkaline "C" cell battery belt or cartridge.
- **Error Analysis.** This unique feature is a great time saver because the calculation of the statistical error of each reading lets the operator make an on-the-spot decision whether that reading should be stored or not.
- **Memory Upgrade.** The standard memory of 1383 readings is optionally expandable up to 2555 readings.
- **Decimal Spacing.** Intermediate readings can be stored every 12.5 units, while using the usual 25-unit station interval.
- **Internal Real-Time Clock.** More accurate and reliable measurements can be made and stored because time is taken to the nearest second. Also, the operator need not wear a wrist-watch, which is a common and often overlooked source of magnetic interference.

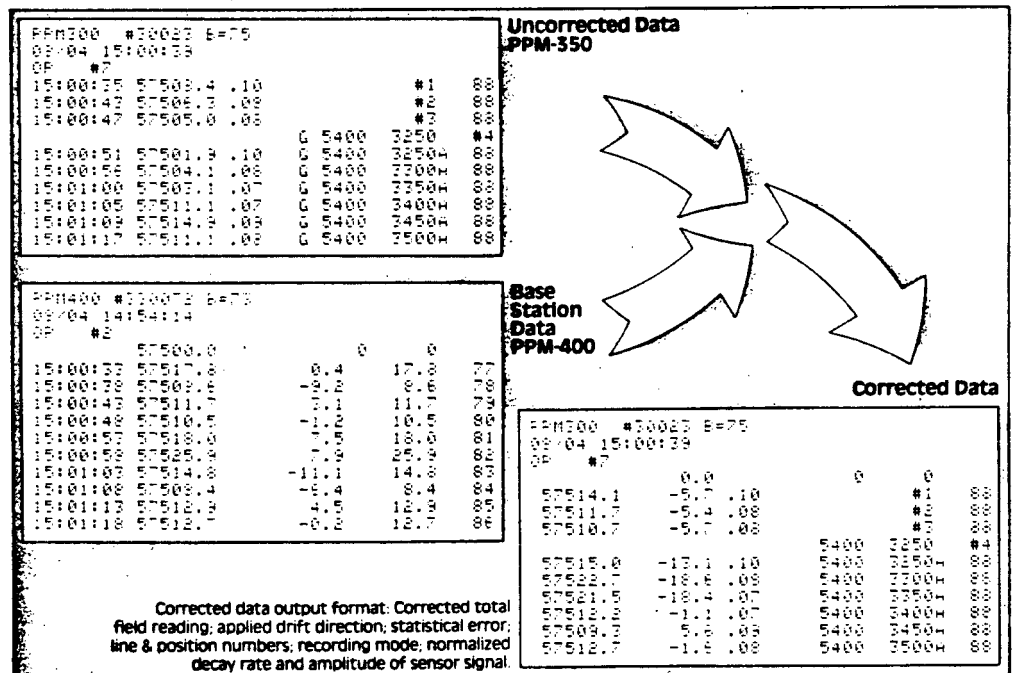

*Patent Pending



Specifications

Dynamic Range	18,000 to 93,000 gammas
Sensitivity	± 0.02 gamma
Statistical Error Resolution	0.01 gamma
Standard Memory Capacity	1383 data blocks or readings
Absolute Accuracy	± 15 ppm at 23°C, 50 ppm over the operating temperature range
Display Resolution	0.1 gamma
Capture Range	$\pm 25\%$ relative to ambient field strength of last stored value
Display	Custom-designed, ruggedized liquid crystal display with an operating temperature range from -35°C to $+55^{\circ}\text{C}$
Gradient Tolerance	5,000 gammas per meter
Sensor	Optimized miniature design. Magnetic cleanliness is consistent with the specified absolute accuracy
Sensor Cable	Remains flexible in temperature range; includes low strain connector
Operating Environmental Range	-35°C to $+55^{\circ}\text{C}$; 0–100% relative humidity; weather-proof
Power Supply	Non-magnetic rechargeable sealed lead acid battery cartridge or belt; or, Disposable "C" cell battery cartridge or belt
Battery Cartridge Life	2,000 to 5,000 readings, depending upon ambient temperature and rate of readings
Weight and Dimensions	
Instrument Console only	3.4 kg, 238 x 150 x 250 mm
Lead Acid Battery Cartridge	1.9 kg
Sensor	1.2 kg, 56 mm diameter x 200 mm
System Complement	Electronics console; sensor with 3-meter cable; sensor staff; power supply; harness assembly; operation manual.

EDA is a pioneer in the development of advanced geophysical systems and has created many innovations that increase field productivity and lower survey costs.

EDA's OMNIMAG series consists of the PPM-350 Total Field Magnetometer, PPM-400 Base Station Magnetometer, and the PPM-500 Vertical Gradiometer. Contact us **now** for details.

EDA Instruments Inc.
1 Thorncliffe Park Drive
Toronto, Ontario
Canada M4H 1G9
Telex: 06 23222 EDA TOR
Cable: Instruments Toronto
(416) 425-7800

In U.S.A.
EDA Instruments Inc.
5151 Ward Road
Wheat Ridge, Colorado
U.S.A. 80035
Telex: 00 450681 DVR
(303) 422-9112

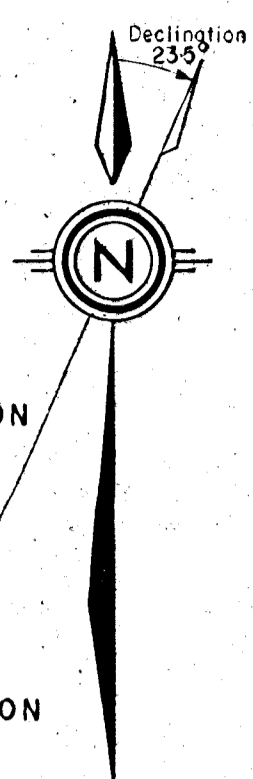
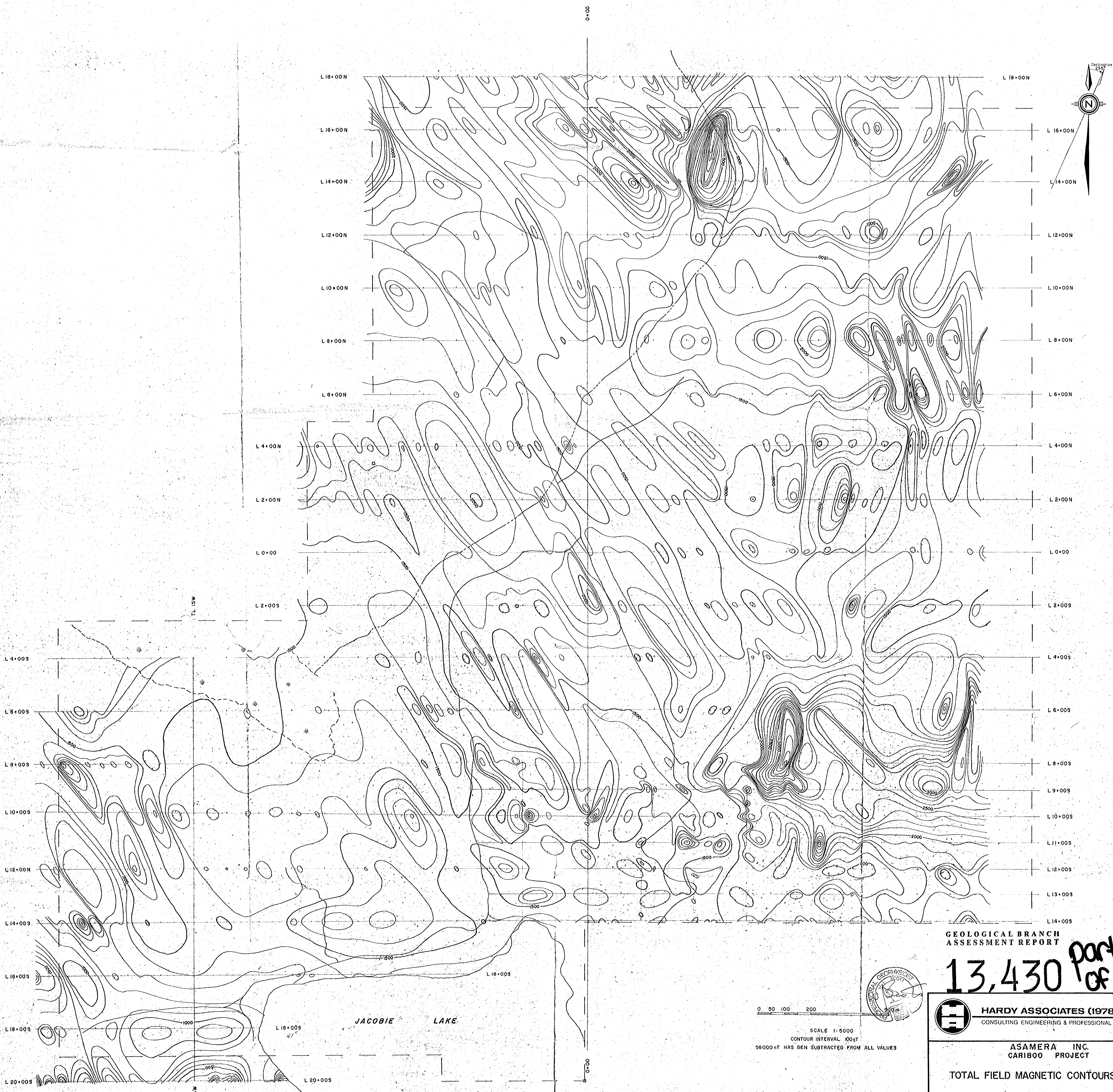

GEOLOGICAL BRANCH
ASSESSMENT REPORT

13,430 *part 3 of 3*

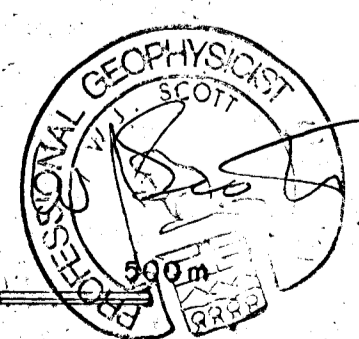

0 50 100 200
SCALE 1:5000
CONTOUR INTERVAL 100G
56000G HAS BEEN SUBTRACTED FROM ALL VALUES

HARDY ASSOCIATES (1978) LTD.
CONSULTING ENGINEERING & PROFESSIONAL SERVICES

ASAMERA INC.
CARIBOO PROJECT

TOTAL FIELD MAGNETIC CONTOURS (nT)

RICK GRID PLATE 1

CG12049

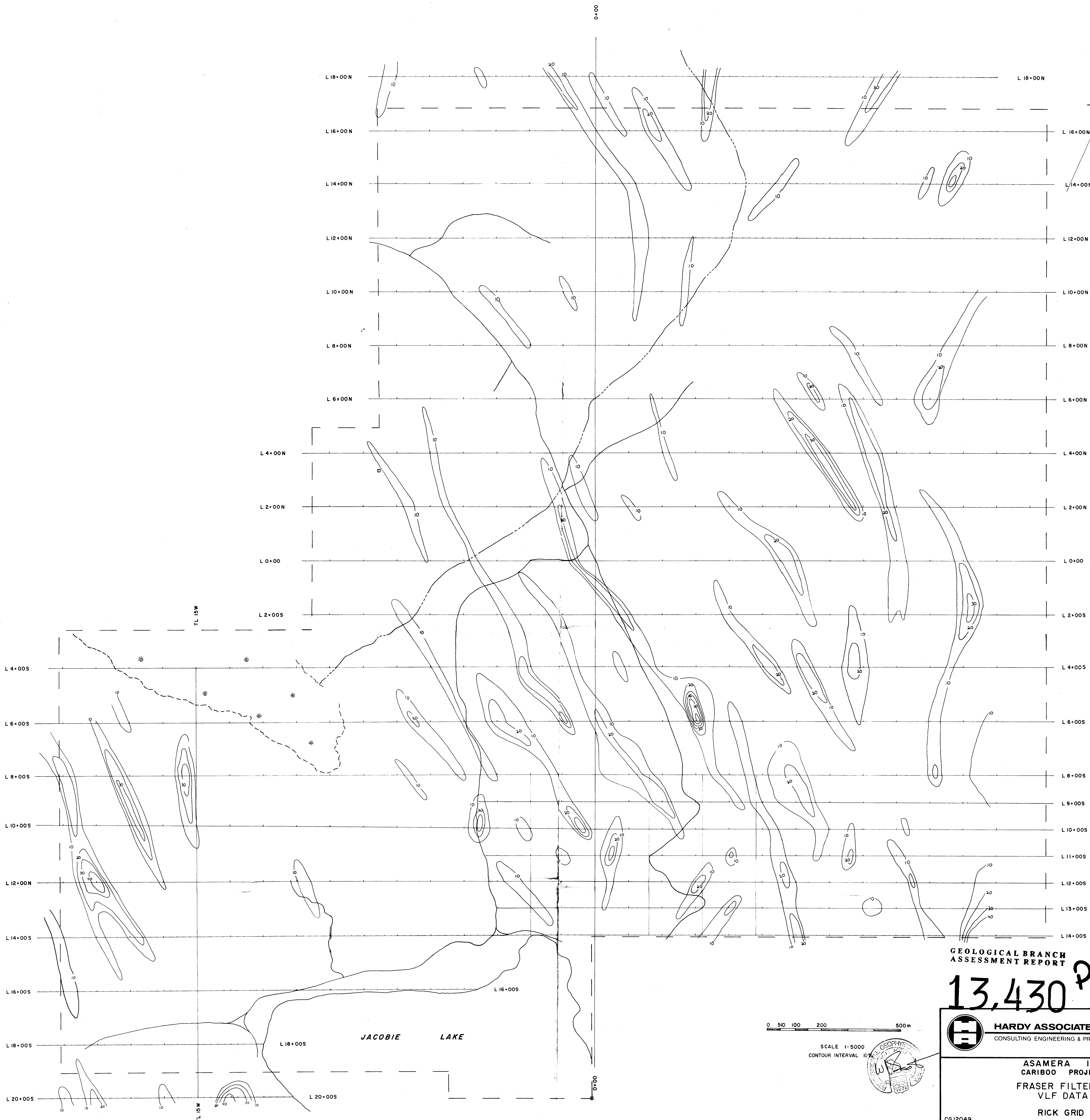

GEOLOGICAL BRANCH
ASSESSMENT REPORT

13,430 Part 3
OF 3



SCALE 1:5000
CONTOUR INTERVAL 10'



HARDY ASSOCIATES (1978) LTD.
CONSULTING ENGINEERING & PROFESSIONAL SERVICES

ASAMERA INC.
CARIBOO PROJECT
FRASER FILTERED
VLF DATA

RICK GRID

CG12049

PLATE 2

0+00

L 18+00N

L 18+00N

L 16+00N

L 16+00N

L 14+00N

L 14+00N

L 12+00N

L 12+00N

L 10+00N

L 10+00N

L 8+00N

L 8+00N

L 6+00N

L 6+00N

L 4+00N

L 4+00N

L 2+00N

L 2+00N

L 0+00

L 0+00

L 2+00S

L 2+00S

L 4+00S

L 4+00N

L 6+00S

L 6+00S

L 8+00S

L 8+00S

L 10+00S

L 10+00S

L 12+00N

L 12+00S

L 14+00S

L 14+00S

L 16+00S

L 16+00S

L 18+00S

L 18+00S

L 20+00S

L 20+00S

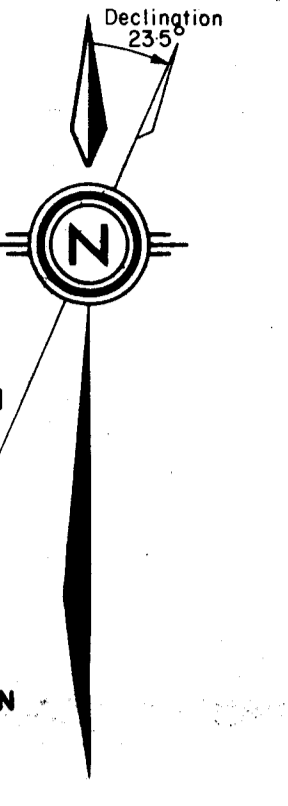

TL 15W

TL 15W

GEOLOGICAL BRANCH
ASSESSMENT REPORT

13,430
part 3 of 3

HARDY ASSOCIATES (1978) LTD.
CONSULTING ENGINEERING & PROFESSIONAL SERVICES



ASAMERA INC.
CARIBOO PROJECT
TOTAL FIELD MAGNETIC DATA (nT)
RICK GRID

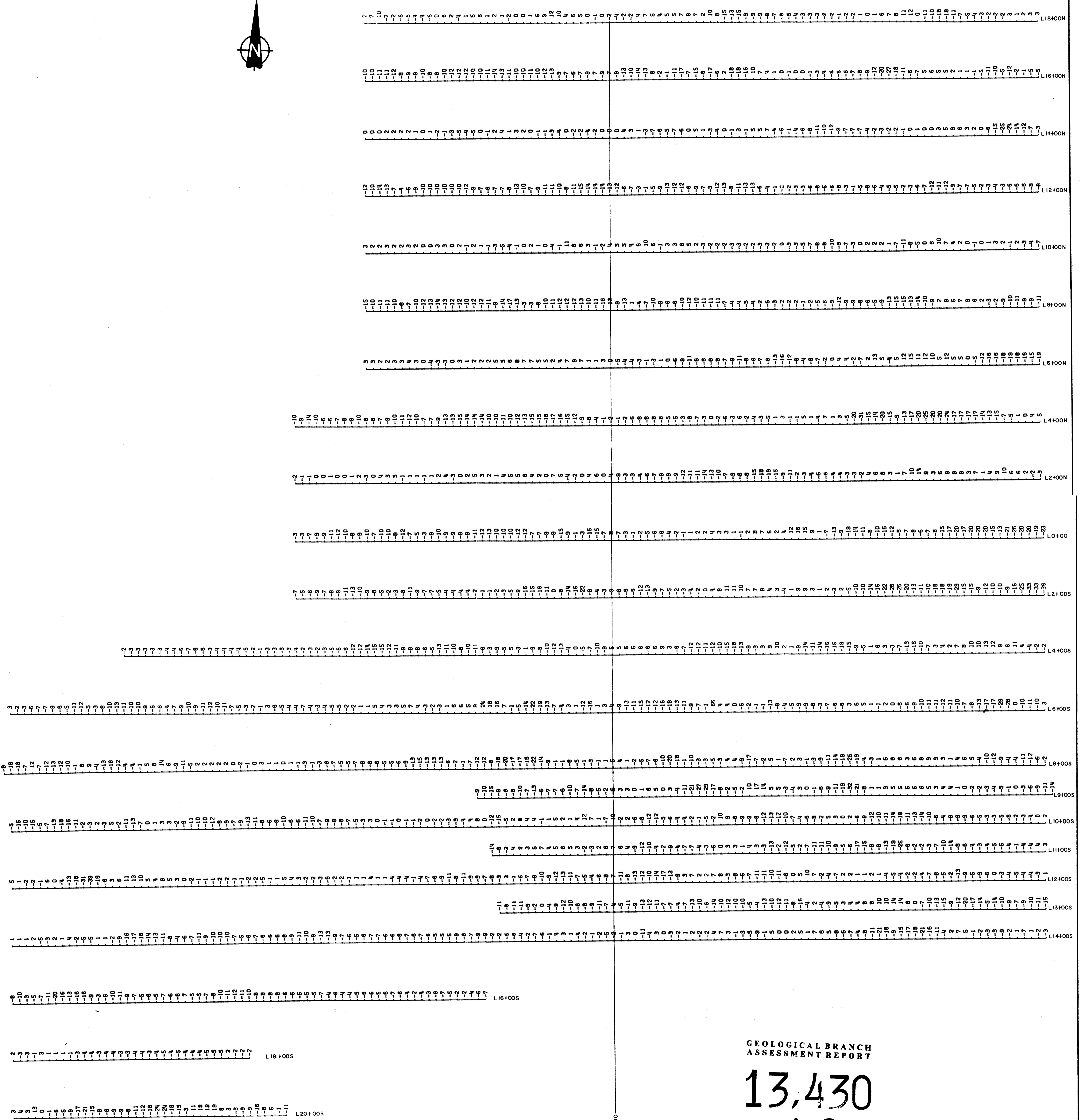
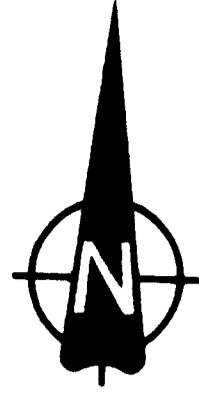

GEOLOGICAL BRANCH
ASSESSMENT REPORT

13,430
Part 3
of 3

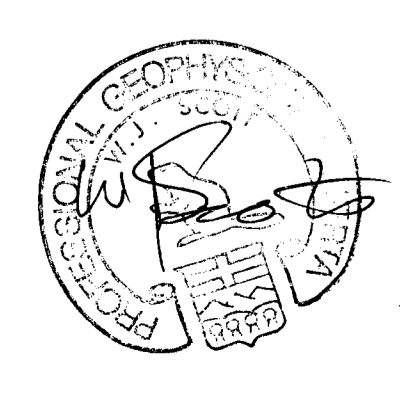
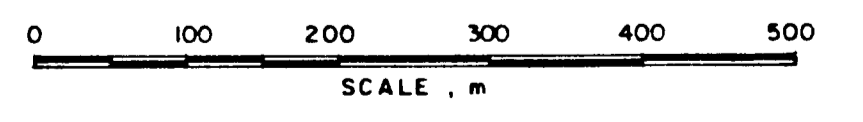

HARDY ASSOCIATES (1978) LTD.
CONSULTING ENGINEERING & PROFESSIONAL SERVICES

ASAMERA INC.
CARIBOO PROJECT
RICK GRID
VLF SURVEY
DIP (%)

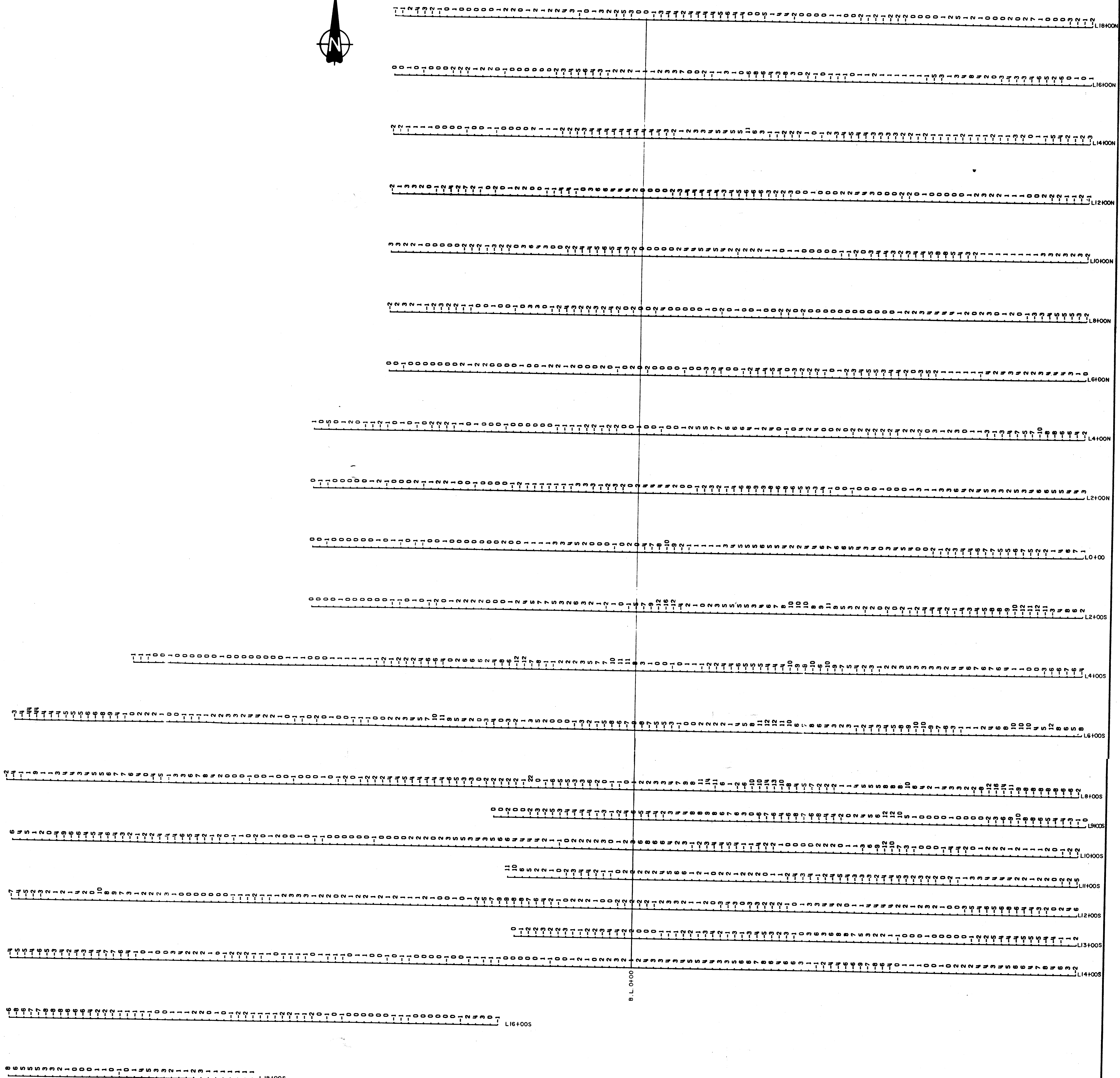
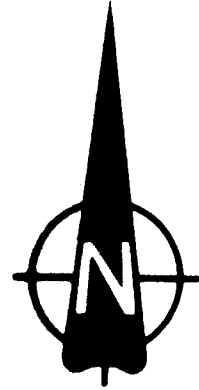

L164000

L184000

L204000

GEOLOGICAL BRANCH
ASSESSMENT REPORT

13,430
part 3 of 3

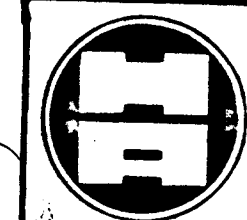
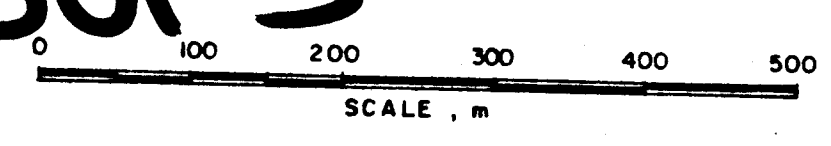

HARDY ASSOCIATES (1978) LTD.
CONSULTING ENGINEERING & PROFESSIONAL SERVICES

ASAMERA INC.
CARIBOO PROJECT
RICK GRID
VLF SURVEY
QUADRATURE (%)