

RECEIVED
APR 02 1998
Gold Commissioner's Office
VANCOUVER, B.C.

AMEROK GEOSCIENCES LTD.

XPLORER GOLD CORP.

**GROUND TOTAL MAGNETIC SURVEY
FIELD AND HLEM SURVEY AT THE
KING SALMON BLOCK
ON THE REDCAP PROPERTY,
TULSEQUAH AREA
NORTHWESTERN BRITISH COLUMBIA**

Carmen Lee, B.Sc.
AMEROK GEOSCIENCES LTD.

CLAIM
REDCAP 1-5
CAT 5

OWNERSHIP
XPLORER GOLD CORP. 100%
XPLORER GOLD CORP. 100%

Operator: Xplorer Gold Corp.
Centred at: 58°47'N, 133°15'W
NTS: 104 K/14
Mining District: Atlin
Date: March 26, 1998

GEOLOGICAL SURVEY BRANCH
ASSESSMENT REPORT

25,460

SUMMARY

Ground total magnetic field and horizontal loop electromagnetic field (HLEM) surveys were conducted on the Red Cap property south of Atlin, BC from March 2 to 8, 1998. The surveys were conducted to delineate the flat lying Stuhini volcanics and to possibly locate mineralization associated with this unit based on the geophysical responses. HLEM surveys were conducted using a coil spacing of 100 metres, station spacing of 25 metres, and reading frequencies of 222, 888, and 3555 Hz. Total magnetic field surveys were conducted over the same grid with a station spacing of 12.5 metres. A total of 1.0 line-km were gridded and surveyed on the King Salmon grid.

In total two anomalies were identified on the King Salmon grid. Anomaly **KS-1** represents a flat lying response and may be associated with the Stuhini volcanics in contact with the King Salmon sediments to the east.

TABLE OF CONTENTS

1.0	INTRODUCTION	1
2.0	LOCATION AND ACCESS	1
3.0	PROPERTY	1
4.0	TOPOGRAPHY AND VEGETATION	2
5.0	HLEM THEORY AND INTERPRETATION PROCEDURES	2
6.0	SURVEY DESCRIPTION AND DATA PRESENTATION	4
7.0	PROPERTY GEOLOGY AND ECONOMIC MINERALIZATION	5
8.0	GEOPHYSICAL RESPONSES	6
9.0	CONCLUSIONS	6
10.0	RECOMMENDATIONS	7
	REFERENCES CITED	8
APPENDIX A.	STATEMENT OF QUALIFICATIONS	9
APPENDIX B.	STATEMENT OF COSTS	10
APPENDIX C.	SURVEY LOG	11

LIST OF FIGURES

Figure 1.	Location and access	following page 1
Figure 2.	Claim location	following page 1
Figure 3.	Grid location for the King Salmon grid	following page 1
Figure 4.	Maxmin Plots (MM1 - MM4)	following page 2
Figure 5a.	King Salmon Grid Total Magnetic Field line plot	back
Figure 5b.	Maxmin profile plot at 222 Hz	back
Figure 5c.	Maxmin profile plot at 888 Hz	back
Figure 5d.	Maxmin profile plot at 3555 Hz	back
Figure 5e.	Composite EM profile plot	back

1.0 INTRODUCTION

Amerok Geosciences Ltd. was retained by Xplorer Gold Corp. to conduct horizontal loop electromagnetic field (HLEM) and ground total magnetic field surveys on the King Salmon block of the Red Cap Property south of Atlin, BC. A total of 1.0 line-km were surveyed on the King Salmon block from March 2 to 8, 1998 to locate Besshi-type volcanogenic massive sulphide mineral deposit. This report describes the surveyed performed, the data, and the results and interpretation.

2.0 LOCATION AND ACCESS

The King Salmon block of the Red Cap Property is situated within the Atlin mining district, northern British Columbia and is located within the area bounded by 58°50'N, 133°20'W and 58°42'N, 133°05'W. The property is located approximately 93 kilometres south south-east of Atlin, BC (see figure 1). Access to the property is by helicopter from Atlin.

3.0 PROPERTY

The King Salmon block consists of the following claims; Red Cap, Red Cap 1-8, Kap 1-10, Cat 5, and King 1-5 (Figure 2). The King Salmon block is located within the Red Cap Property which is bounded by the Taku River to the northwest, the Zohini Creek to the south, and by Lisadele Lake to the southeast. The grid location of the King Salmon block is shown in Figure 3. The claims are described as follows:

<u>Claim</u>	<u>Tenure No.</u>	<u>Ownership (percentage)</u>	<u>Expiry date¹</u>	<u>Units</u>
Red Cap 1	345066	Xplorer Gold Corp. (100%)	98/03/28	20
Red Cap 2	345067	Xplorer Gold Corp. (100%)	98/03/28	20
Red Cap 3	355000	Xplorer Gold Corp. (100%)	98/04/14	20
Red Cap 4	355001	Xplorer Gold Corp. (100%)	98/04/14	20
Red Cap 5	345065	Xplorer Gold Corp. (100%)	98/03/28	8
Cat 5	325569	Xplorer Gold Corp. (100%)	98/05/15	5

¹Expiry dates as of March 25, 1998 per information provided by the BC Department of Mines



YUKON TERRITORY

BRITISH COLUMBIA

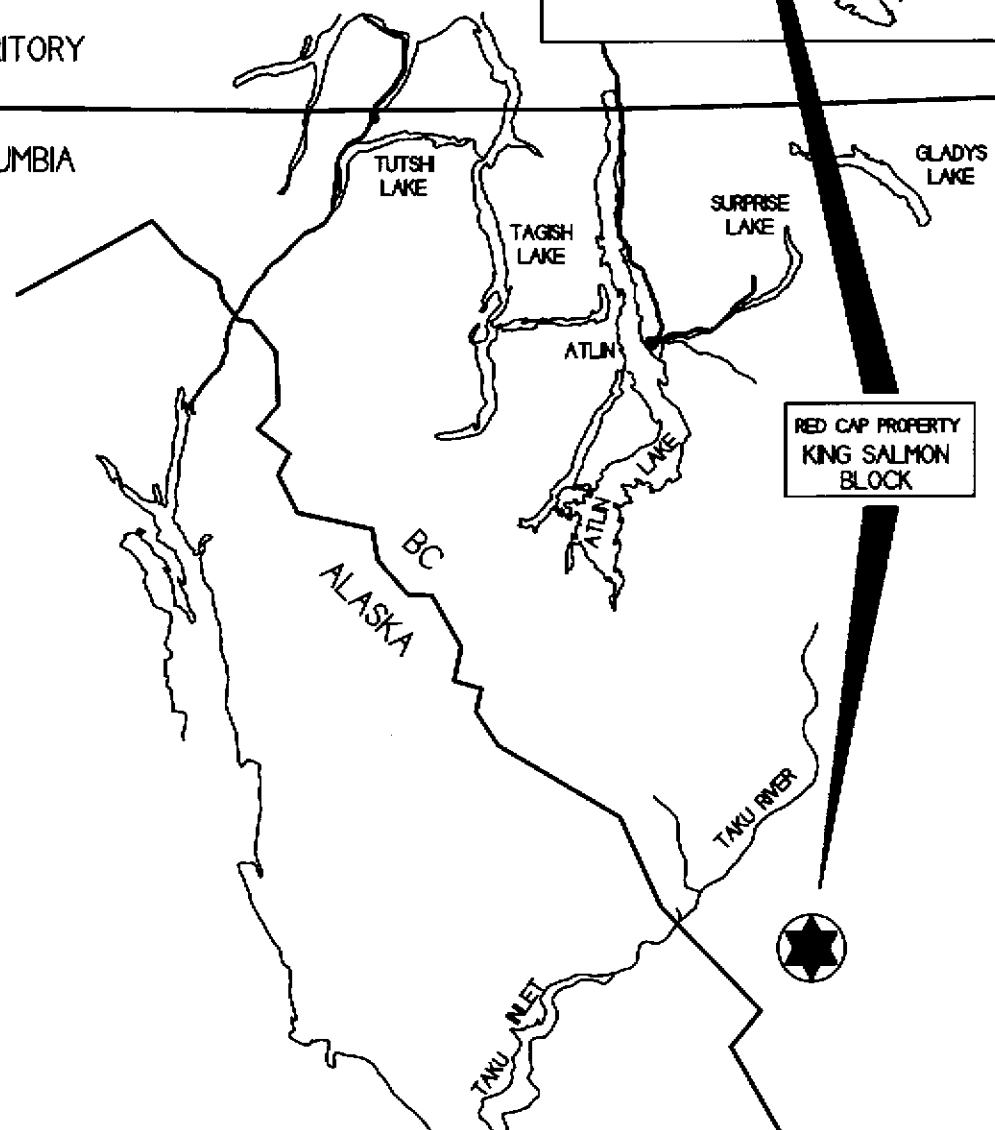





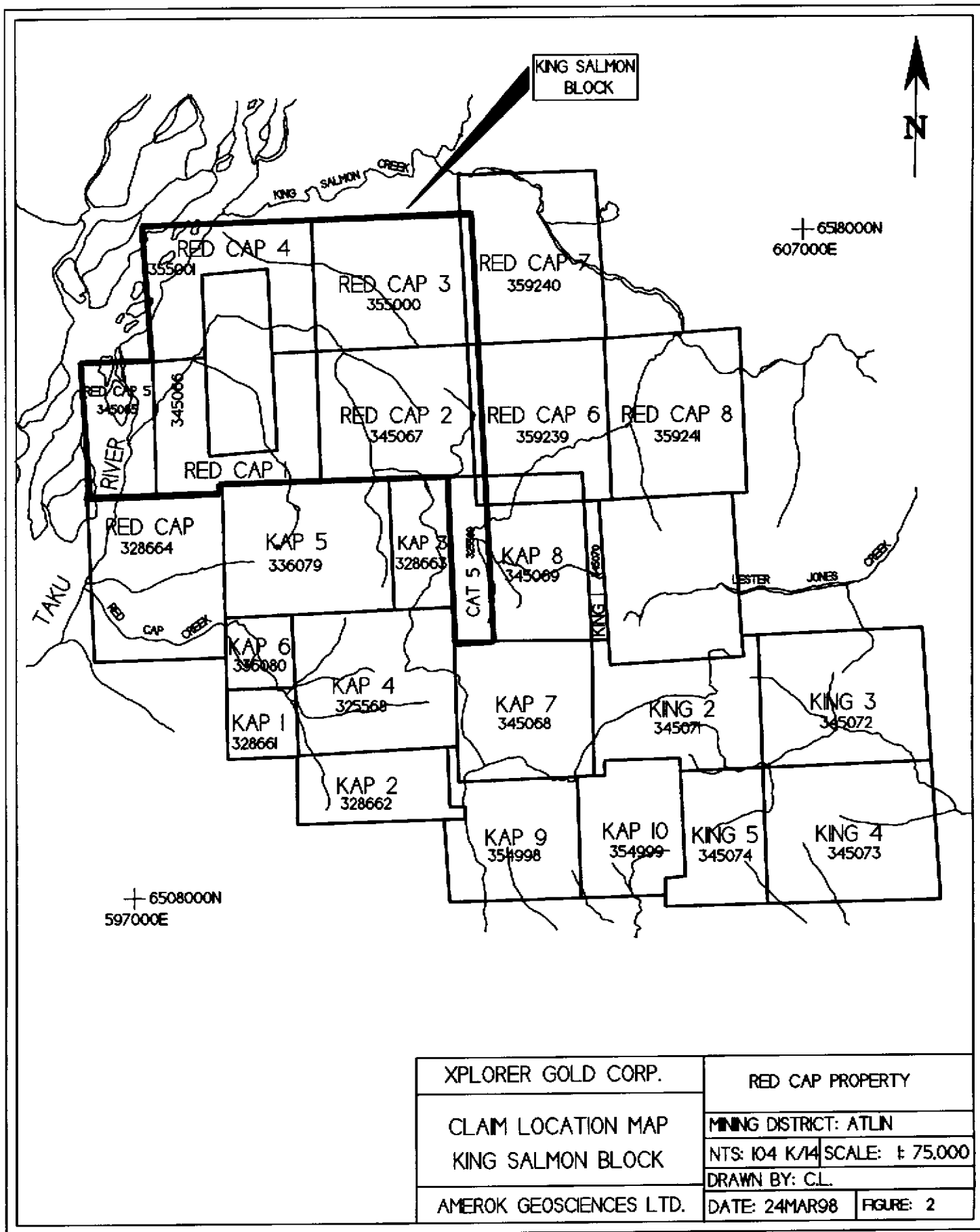

RED CAP PROPERTY
KING SALMON
BLOCK

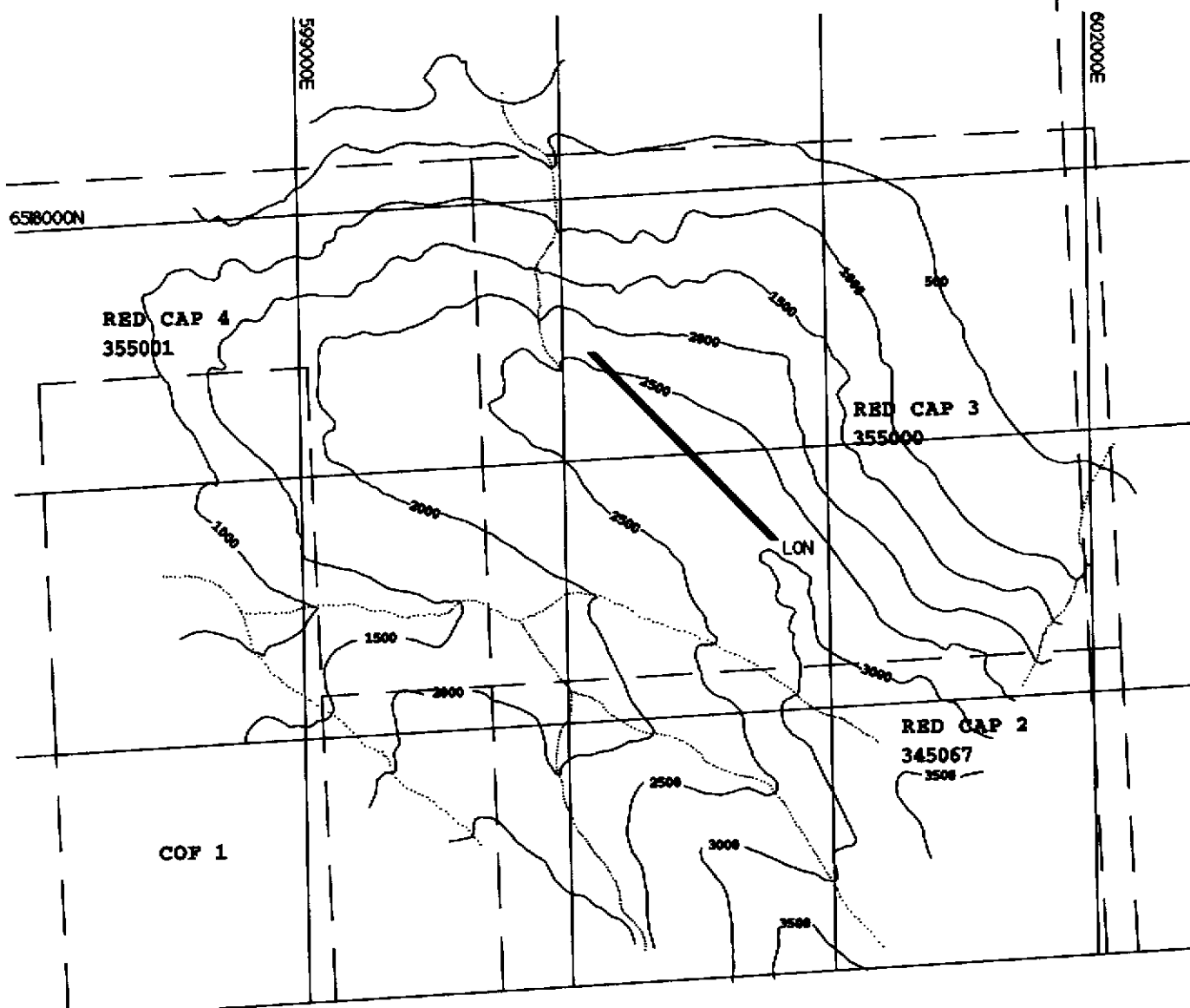
XPLORER GOLD CORP.	RED CAP PROPERTY CLAIMS: KING REDCAP.KAP.CAT
LOCATION AND ACCESS KING SALMON BLOCK	MINING DISTRICT: ATLIN
	NTS: J04 K/14 SCALE: 1:457,700(A)
	DRAWN BY: C.L.
AMEROK GEOSCIENCES LTD.	DATE: 18 MARCH 98 FIGURE: 1

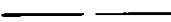

XPLORER GOLD CORP.	RED CAP PROPERTY	
CLAIM LOCATION MAP KING SALMON BLOCK	MINING DISTRICT: ATLIN	
	NTS: 104 K/14	SCALE: 1:75,000
AMEROK GEOSCIENCES LTD.	DRAWN BY: C.L.	
	DATE: 24MAR98	FIGURE: 2



-  3000 ELEVATION ABOVE SEA LEVEL
-  CLAIM BOUNDARY
-  UTM (NAD 27)
-  DRAINAGES
-  SURVEY LINE

XPLORER GOLD CORP.		RED CAP PROPERTY CLAIMS: RED CAP 3	
KING SALMON GRID		MINING DISTRICT: ATLIN	
		NTS: 104K/14	SCALE: 1:25,000
AMEROK GEOSCIENCES LTD.		DRAWN BY: G.S./C.L.	
		DATE: 21 MARCH 98	FIGURE: 3

4.0 TOPOGRAPHY AND VEGETATION

The Red Cap property is located within the Coast Mountain Boundary Ranges with elevations ranging from 2900 feet at the King Salmon grid to 5800 feet at the Kap grid. The topography at the King Salmon grid is a narrow 'hummocky' ridge covered with open stands of pine and spruce bounded on either side by outcrops semi-exposed by snow cover. Both the Kap and the Lester Jones grids are located on ridge tops above the tree line. The Kap grid is surrounded by cliffy outcrops and snowfields whereas the Lester Jones grid is situated on top of a broad generally flat ridge with sparse pockets of small spruce.

5.0 HLEM THEORY AND INTERPRETATION PROCEDURES

The horizontal loop EM method is well described in standard text such as Telford et. Al. (1990) and Ketola and Puranen (1967). This section summarizes the key features of the HLEM method and describes the interpretation algorithms used in this survey program.

The HLEM method involves the use of a pair of separated horizontal coils (Figure MM1). Most commonly, the surveys are conducted in the frequency domain. In this method, a sine wave of variable frequency is sent through one of the coils to create a time-varying vertical magnetic dipole source. The second coil is a receiver which detects both the primary signal from the transmitting coil and a secondary signal created by magnetic induction in a conductive target in the earth. There are two variants of the method in the frequency domain are the Slingram or conventional HLEM method and the Genie method. Slingram is often referred to as HLEM despite the more general nature of this term and we follow this convention throughout the remainder of this report.

The HLEM method requires that a sample of the transmitted signal be sent along a wire to the receiver where it is used to synchronize the phase of the receiver with the transmitter. This permits the receiver to remove the effect of the transmitter signal (primary field) and to split the remaining secondary field into two components. One phase with the primary field (in-phase component). The second component is the portion of the secondary field which lags the primary field by one quarter cycle (90° - quadrature component). The ratio of the in-phase to quadrature components is used to determine the electrical conductance of a target.

HLEM instruments remove the primary field from the signal to leave only the secondary field. By convention, a secondary field in the same direction as the primary field is

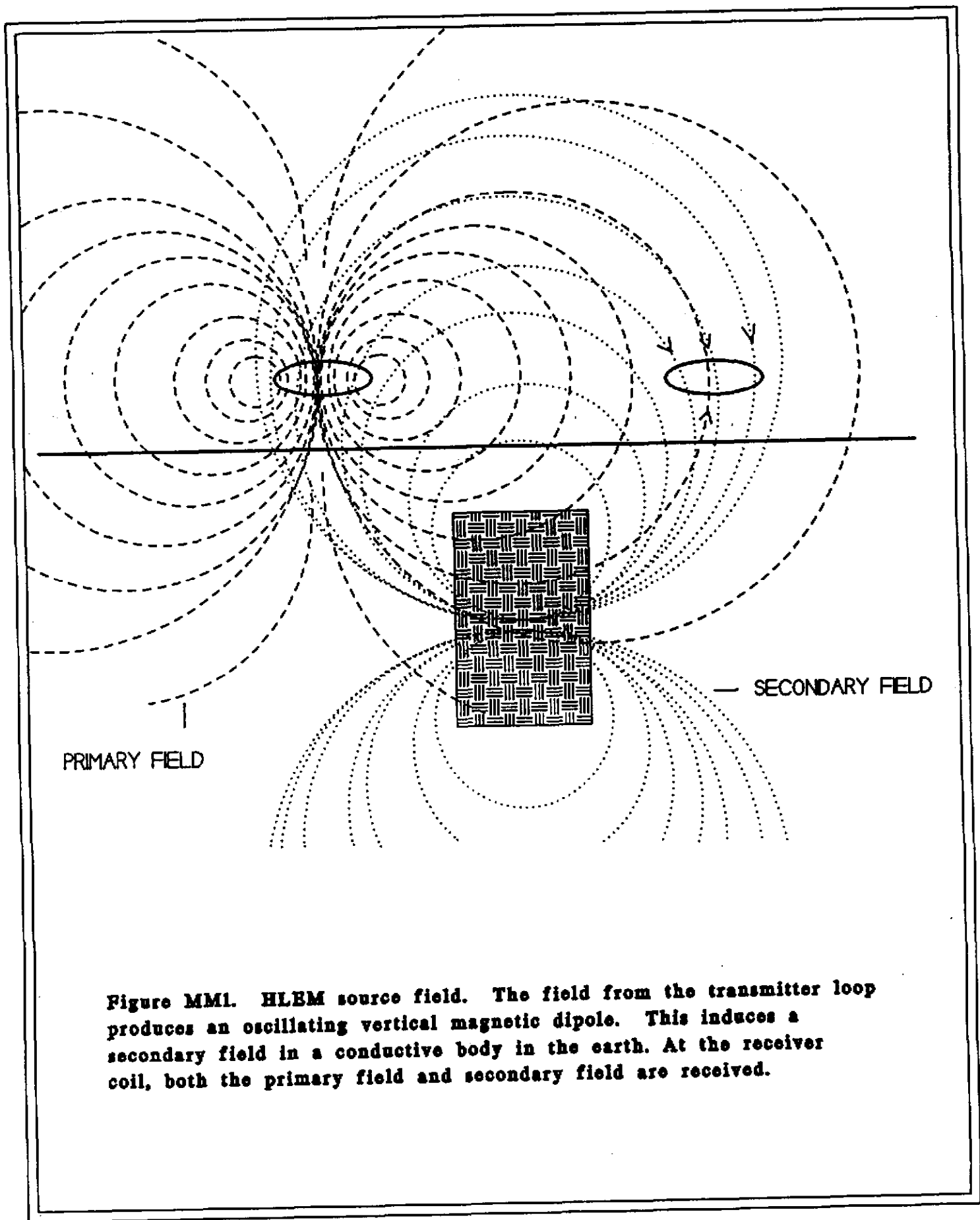

Figure MM1. HLEM source field. The field from the transmitter loop produces an oscillating vertical magnetic dipole. This induces a secondary field in a conductive body in the earth. At the receiver coil, both the primary field and secondary field are received.

recorded as positive while a secondary field in the opposite direction to the primary field is recorded as negative. HLEM data is commonly plotted as profiles with the reading plotted at the midpoint between the transmitter and receiver. The reason for this is that the response from a steeply dipping conductor, the most common target of this method, is strongest when the two coils straddle the conductor. Normally, the in-phase response is plotted as a solid line and the quadrature response as a dashed line.

The HLEM response of a flat lying body is shown in Figure MM2. Magnetic field lines (flux) are directed primarily into the region beneath the transmitter loop. Lenz's Law dictates that the induced secondary field will oppose the primary field. Consequently, at the receiver, both the primary and secondary field will be in the same direction. As a result, the response from a flat lying conductor consists of a positive response over the target. At the edge of the conductor, there is a negative response which occurs when both coils are straddling the edge of the conductor. When either the transmitter or receiver coil is over the edge of the conductor, there is no secondary field and the response is zero. As the depth to the flat lying conductor increases, the strength of the response is attenuated. The effective depth of investigation of the HLEM method for a flat lying conductor is approximately 1.5 times the coil spacing.

The HLEM response of a steeply dipping conductor is shown in Figure MM3. Field lines from the transmitter are horizontal at a point midway between the two coils and in this orientation, cut the conductor at right angles creating the best coupling. Lenz's Law dictates that the secondary field will oppose the primary field and at the receiver coil, the secondary field is in the opposite direction to the primary field. As a result, the response when profiling over a steeply dipping conductor consists of a trough with peak negative value occurring when the coils straddle the conductor. The flanking positive peaks result from induction effects as the pair of coils are close to but not straddling the conductor. When either of the coils is directly over the target, the response is zero because the primary field is not well coupled with the target (i.e., it is perpendicular to the edge of the conductor) and little secondary field is created.

A dipping tabular conductor can be specified by the dip and dip direction, depth to top, target width, and electrical conductance (conductivity thickness product or σt). The effect of varying these parameters is shown in Figure MM3 for the case of a response from a single isolated HLEM conductor. Asymmetry in the positive shoulders indicates the dip direction and the ratio of the positive shoulder responses can be used to estimate the dip (Figure MM3(a)). The strength of the response is largely determined by the depth to the top of the conductor. Increasing the depth to the top of the conductor decreases the amplitude of the response but does not otherwise change the shape of the response (Figure MM3(b)). The effective depth of investigation of the

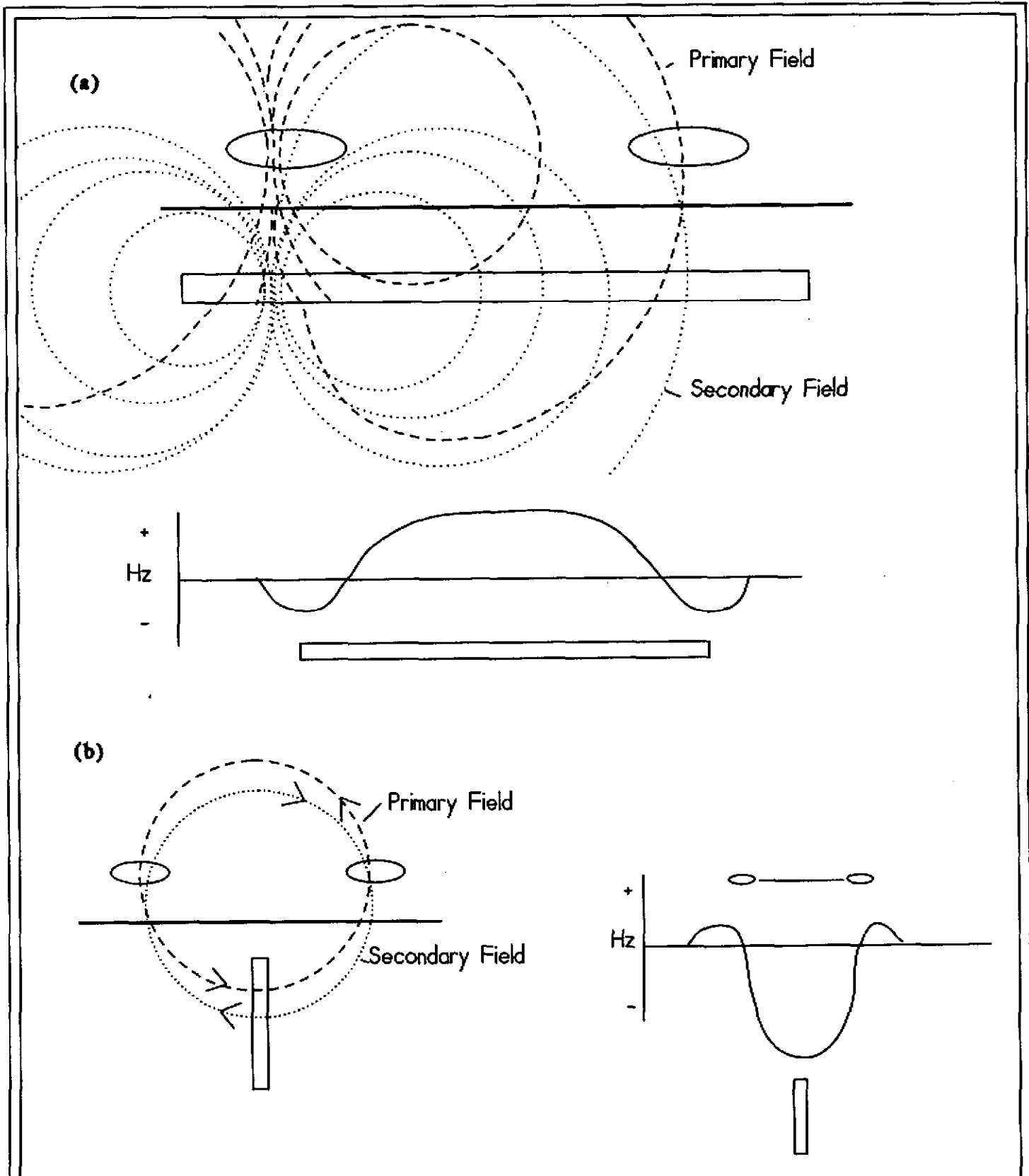
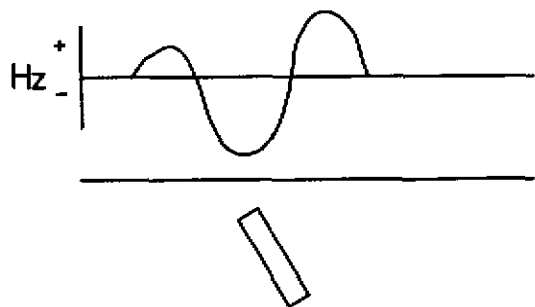
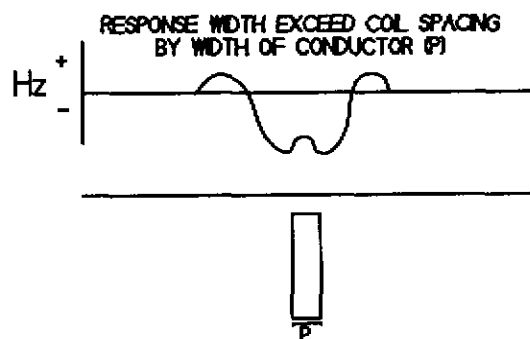

Figure MM2. HLEM responses. (a) Response over a flat-lying conductor consists of a positive response. (b) Response over a dipping conductor consists of a negative response.

(a)



(b)



(c)

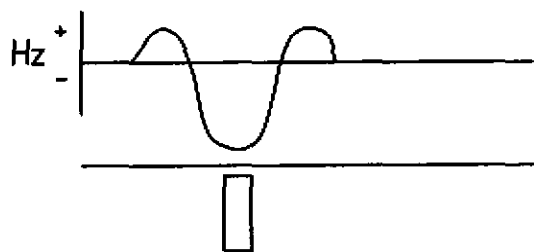

(d)

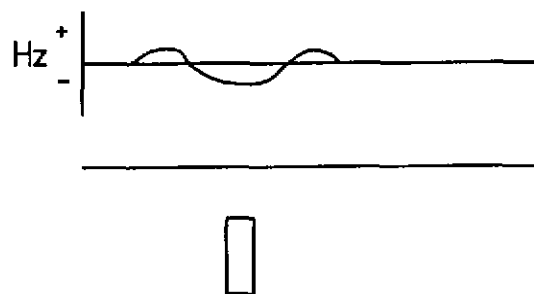
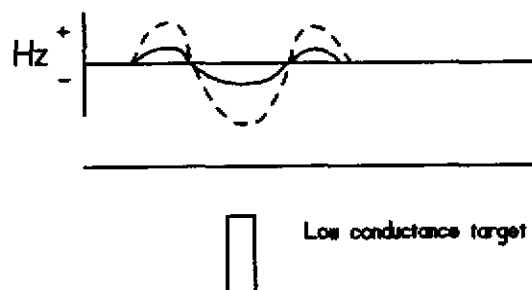

Figure MM3. HLEM response of dipping tabular conductors. (a) Effect of d on HLEM response. (b) Effect of depth. (c) Effect of conductor width. (d) Effect of conductance.

HLEM method for steeply dipping targets is approximately one half the coil spacing. If the conductor is wide, the location of the zero crossovers, normally equal to the coil spacing, will increase. If the width of the target approaches that of the coil spacing, the positive return in the trough will be apparent at any depth to target (Figure MM3(c)). As noted above, the electrical conductance controls the ratio of the in-phase to quadrature response. Weak targets show only a quadrature response. As the target conductance increases, the strength of the in-phase component will increase. Very high conductance targets are characterized by strong in-phase responses and weak to very weak quadrature responses (Figure MM3(d)).

Interpretation procedures for HLEM data are dependent upon the model to which the data is to be fitted. In most cases, the characteristic shape of the response will dictate the likely overall geometry of the source and thus the model to which the response should be fitted. Flat lying targets can be directly modeled with computerized calculations of target responses. Dipping tabular body responses on the other hand cannot be numerically modeled and must either be approximated through finite element models or interpreted using characteristic curves. Characteristic curves for tabular dipping conductors incorporate several key features of the responses described in Figure MM4 into simple charts. These responses are derived from model experiments. The ratio of positive shoulders responses and the ratio of in-phase to quadrature peak negative values are the commonly used features of the response.

The data contained in this report was interpreted using characteristic curves developed by Ketola and Puranen (1967). The procedure, normally done by hand, has been automated in proprietary software (MMPLOT) developed by Amerok Geosciences Ltd. The characteristics of each response are entered into the computer program which creates a batch plotting file. The data is plotted directly on a CADD diagram with each of the characteristic curves (i.e. by changing layers). Where the data falls between two curves, the conductance and depth to top parameters can be interpolated but the dip cannot be readily determined.

6.0 SURVEY DESCRIPTION AND DATA PRESENTATION

The geophysical surveys were performed over a flagged and picketed grid covering most of the ridge tops within the Red Cap property south of Atlin, BC. The survey lines were slope chained (not slope corrected) and spaced every 50 metres where possible and picketed at 25 metre station spacings. Line locations were surveyed in with a differential hand held GPS as well as with the helicopter GPS.

The surveys were conducted by Carmen Lee (geologist), Ron Stack (technician), and

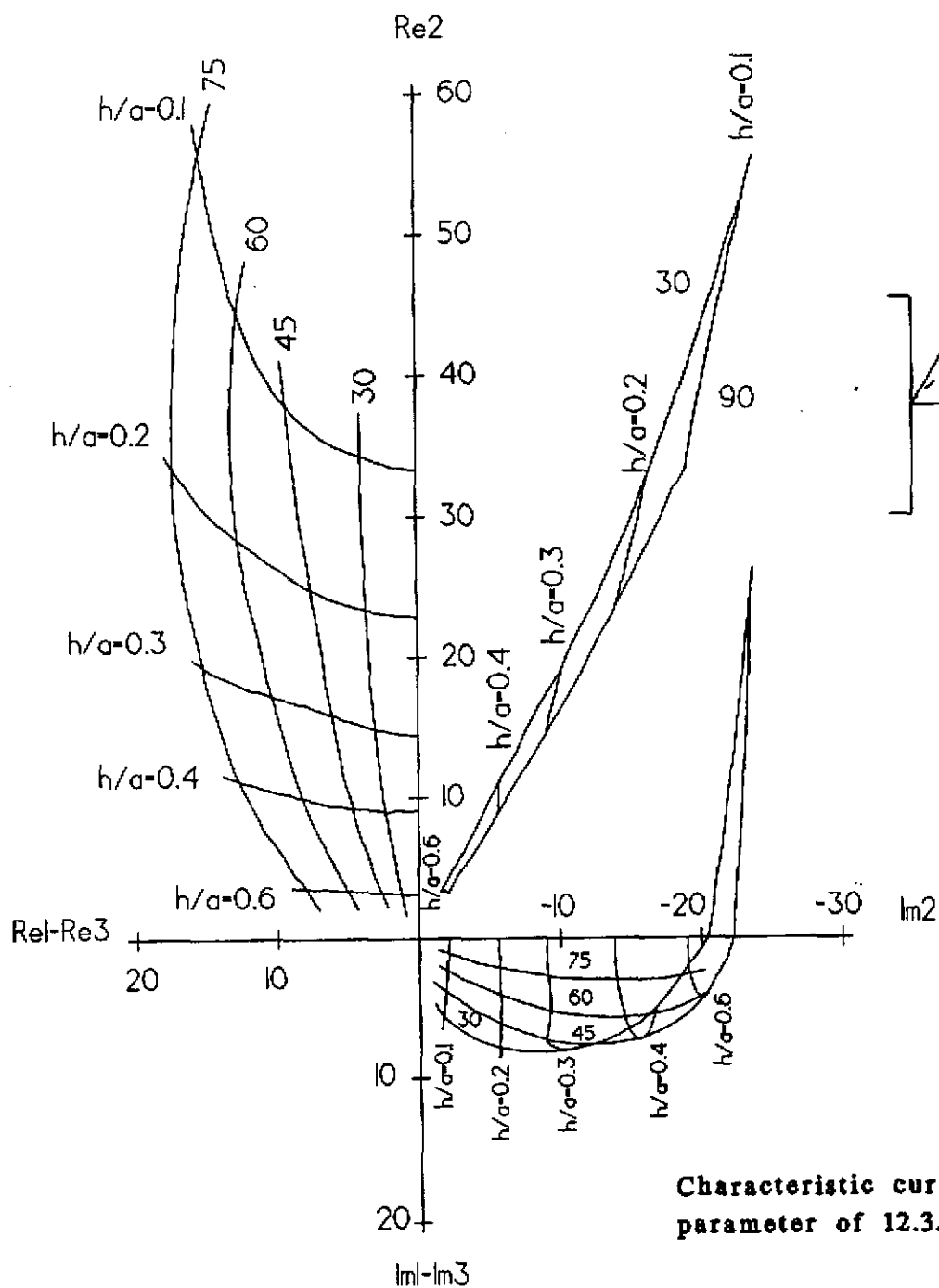

Characteristic curve for response parameter of 12.3.

Figure MM4. Characteristic curve for a dipping tabular conductor from Ketola and Puranen (1967). Critical measurements of the response shown in the upper right are extracted and plotted to determine the geometry and conductance of the target.

Rick Smith (technician) between March 2 and 8, 1998. The crew was equipped with an Apex Parametrics Maxmin II equipped with an on-board computer (MMC) and the data dumped daily to a P-75 laptop computer. The total magnetic field surveys were performed with a Omni Plus proton magnetometer and a synchronized base station magnetometer.

The total magnetic field data was corrected using a synchronized base station magnetometer located in a magnetically quiet area and cycling at a 10 second reading interval. The geomagnetic field was generally quiet throughout the survey. No cultural noise was recorded throughout the survey.

The following procedure was used to correct the HLEM data for terrain induced errors. The operators maintained a fixed 100 metre between the receiver and transmitter using chainage marks on the reference cables. At each reading the receiver operator measures the station-to-station terrain slope and enters this into the MMC. During post-acquisition data processing, the data was corrected for short chainages induced by topography by using the MMCFIX1 software developed by Apex Parametrics. The method is fully explained in Varre (1994). The overall noise envelope appears to be +/- 2%.

The HLEM data is plotted in Figures 5a through 5e in stacked profile format at 1:3000. These plots show the survey grid and the profile data as in-phase (solid) and quadrature (dashed) components of the secondary vertical magnetic field as a percentage of the primary field. The profile vertical scale is 10% /cm, right of line positive or upwards of line positive, with a base level of zero coincident with the survey lines. Anomalies of interest are annotated with symbols describing the interpreted conductor parameters.

7.0 PROPERTY GEOLOGY AND ECONOMIC MINERALIZATION

The Red Cap Property is underlain by Upper Triassic Stuhini Volcanics, Cretaceous - Tertiary quartz monzonite intrusives, and Cretaceous / Tertiary quartz feldspar porphyry dykes.

The Kap grid hosts four major rock units which are: 1). quartz monzonite to granodiorite; 2). felsic volcanics (rhyolite); 3). andesite (Stuhini volcanics); and 4). quartz feldspar porphyry dykes. Similarly, the Lester Jones grid predominantly consists of the Stuhini volcanics and the quartz feldspar porphyry dykes. These radiating porphyry dykes are thought to have originated from a plug to the south of the property. At the King Salmon grid, greywackes, mudstones, siltstones, and sandstones of the

King Salmon Formation occur in contact with the Stuhini volcanics. This contact is thought to strike east-west across the ridge dipping to the north north-east along the dip slope of the anticline (Elliott, pers comm., 1998).

Mineralization occurs within the flat lying to gently dipping Stuhini volcanics along the contact between the volcanics with the intruding granodiorites. Here the margins are highly altered and pyritized. Mineralization also occurs within the micro-veinlets found in shear zones containing pyrite-copper-molybdenite and polymetallic base metals. These veinlets were formed by pressurized hydrothermal solutions fracturing into the overlying capping volcanics. A later stage of fracturing produced silver-gold-arsenopyrite veinlets which may have formed from the same hydrothermal solution (Murton and Woods, 1988).

8.0 GEOPHYSICAL RESPONSES

On the King Salmon grid two anomalies, **KS-1** and **KS-2** (Figure 5a - 5e) were identified within the 1.0 line-km surveyed. **KS-1** occurs at the western end and is characterized best by using 50 metre coil spacings at 3555 Hz. The anomaly here is weak with a conductivity thickness product of less than one Siemen (S). Anomaly **KS-2** is depicted by a large EM positive in-phase and little quadrature response occurring in all three frequencies. Interpretation of the response suggests that the source body is flat lying and is either highly conductive or magnetic or both and may possibly represent the Stuhini volcanics.

9.0 CONCLUSIONS

Results of the survey lead to the following conclusions:

- a. No significant conductors which could be caused by massive sulphide mineralization were located by the HLEM surveys.
- b. Conductor **KS-2** may possibly represent the Stuhini volcanics.

10.0 RECOMMENDATIONS

The following recommendations are made:

- a. Anomaly KS-2 should be investigated on line ON. The conductor apex is at 275W and the conductor appears to be conformable with the local bedding.

These recommendations should be reviewed in the light of available new geological and geochemical mapping.

Respectfully submitted,
AMEROK GEOSCIENCES LTD.



Carmen Lee, B.Sc.
Geologist

REFERENCES CITED

Telford, W.M., L.P. Geldart and R.E. Sheriff (1990) Applied Geophysics (2nd Edition).
New York: Cambridge University Press.

Ketola, M. and M. Puranen (1967) Type curves for the interpretation of Slingram
(Horizontal loop) anomalies over tabular bodies. Geological Survey of Finland
Report of Investigations No.1.

Murton, J.C. and D.V. Woods (1988) Geophysical Report on an Airborne Magnetic and
VLF-EM Survey. Western Geophysical Aero Data Ltd.

Varre, T. (1990) Apex Parametrics Maxmin I-9 manual. Uxbridge: Apex Parametrics.

APPENDIX A. CERTIFICATE

I, Carmen C. Lee, B.Sc., with residence address in Whitehorse, Yukon Territory do hereby certify that:

1. I am a graduate of the University of Calgary with a B.Sc. Degree in Geology obtained in 1996.
2. Since 1996, I have been employed continuously as a geophysical party chief for Amerok Geosciences Ltd., running magnetic field, electromagnetic, induced polarization surveys on properties in the Yukon, Alaska, and northern British Columbia.

Dated this 23rd day of March, 1998 in Whitehorse, Yukon Territory.



Carmen C. Lee, B.Sc.

APPENDIX B. STATEMENT OF COSTS

Helicopter charter (Discovery Helicopters - Atlin BC)	\$13,285.14
Geophysical surveys (Amerok Geosciences Ltd.)	\$11,086.38
Survey report and map digitizing	\$3,000.00
Project supervision - T. Elliott (Xplorer Gold Corp.) (Airfare, wages, expenses)	<u>\$2,650.00</u>
Total	\$30,021.52

These costs were incurred in the exploration of the REDCAP 1-5, CAT 5, KING 1-5 and KAP 4-10 claims and the following exploration expenses, apportioned by the amount of time spent on each block, are applied to the claims:

KAP 9-10 KING 2-5	33% (\$10,007.17)
KAP 4-8 KING1	33% (\$10,007.17)
REDCAP 1-5 CAT 5	33% (\$10,007.17)

I certify that I supervised the project described in this report and that these costs are true and correct to the best of my knowledge.

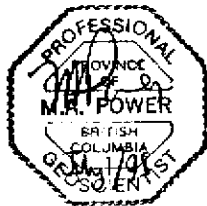

Michael A. Power M.Sc. P.Geoph. P.Geo.
Geophysicist

Whitehorse, Yukon Territory
July 1, 1998

APPENDIX C. SURVEY LOG

SURVEY LOG
XPLORER GOLD CORP.
MAXMIN AND MAGNETOMETER SURVEYS - RED CAP PROPERTY
MARCH 2 - 8, 1998

02March98 Mobe to Atlin late in the afternoon with Terry Elliot of X-plorer Gold.

03March98 Slow start to the day due to poor flying conditions. Recon location of the three grids. Started gridding and Maxmin survey on the King Salmon grid.

L1N 0W - 1000W

total: 1.0 line-km maxmin

04March98 Red Cap grid. Gridded and Maxmin survey along the ridge. Put in two lines to optimize the width of the ridge and extended the lines as far as possible.

L0W 0N - 525N

L50W 0N - 475N

total: 1.0 line-km maxmin

05March98 Red Cap grid. Gridded and Maxmin survey further to the south of the previous grid. Ran 150m detail over the entire line.

L125W 0S - 575S

total: 1.15 line-km maxmin

06March98 Red Cap grid and King Salmon grid. Ran mag and detail 50m maxmin survey over the Red Cap grid. Mag and detail 150m and 50m maxmin survey on the King Salmon grid.

Red Cap:

L0W 0 - 525N mag

L50W 0 - 475N mag

L125W 0 - 575S mag

L125W 0 - 575S maxmin

King Salmon:

L0N 0 - 1000W mag

LON 625 - 1000W 150m maxmin
LON 750 - 1000W 50m maxmin

total: 1.2 line-km maxmin
2.575 line-km mag

07March98 Lester Jones grid. Gridded and Maxmin survey.

LON 0 - 1200E
L50N 100 - 1200E
L100N 150 - 1900E

total: 4.050 line-km maxmin

08March98 Lester Jones grid. Mag and detail maxmin survey. Demobe back to Whitehorse.

LON 0 - 1200E mag
L50N 100 - 1200E mag
L100N 150 - 1900E mag
L150N 375 - 1400E mag and maxmin
LON 0 - 400E 150m and 50m maxmin
L50N 425 - 675E 150m and 50m maxmin

Total: 5.075 line-km mag
1.3 line-km maxmin

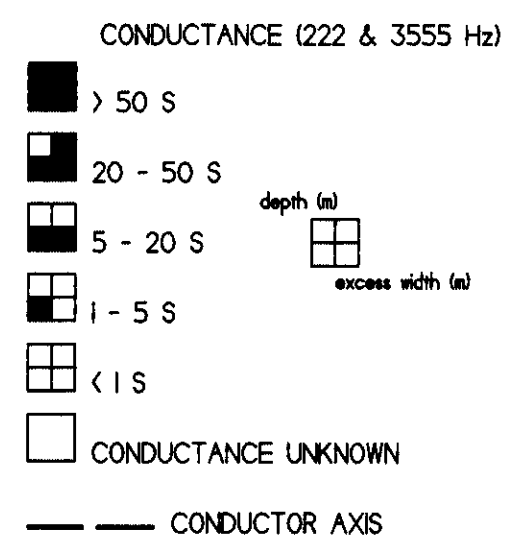
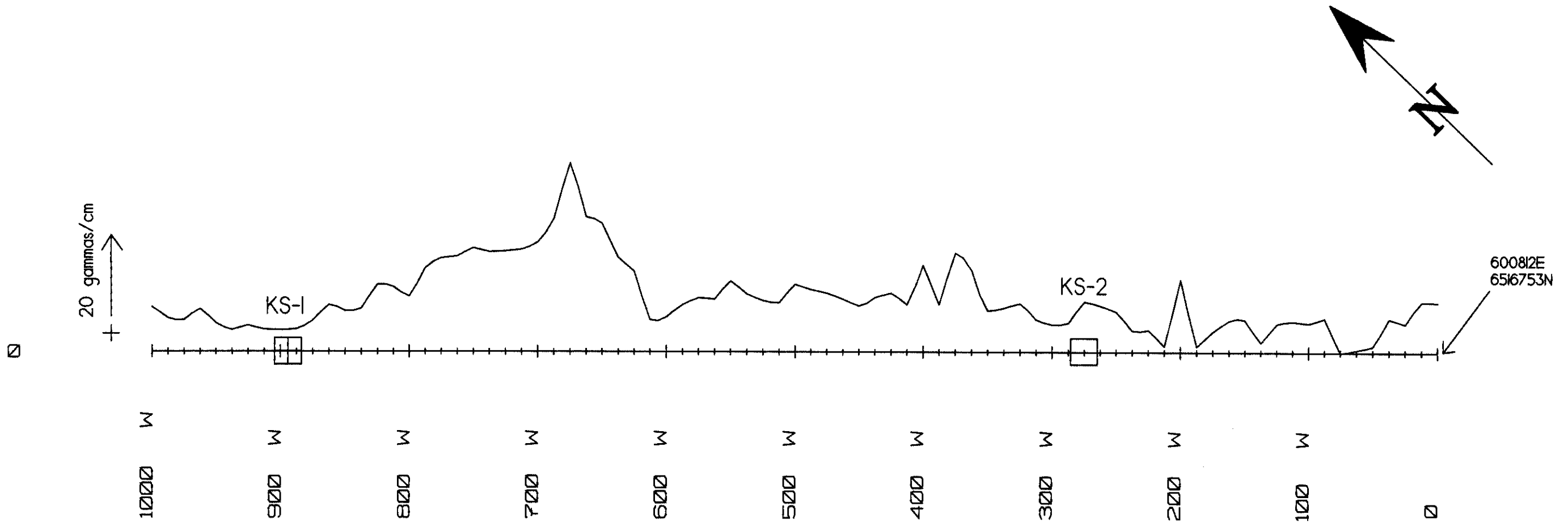

BASE LEVEL at 57050 Gammas
 VERTICAL SCALE: 20 Gammas/cm (increasing upwards)

X-plorer Gold Corp.	RED CAP PROPERTY KING SALMON GRID
TOTAL MAGNETIC FIELD LINE PLOT	CLAMS: CAP 3
AMEROK GEOSCIENCES LTD.	NTS: 104 K/14 SCALE: 1:3000
	OPERATOR: R.S.
	DATE: 11 March 98
	FIGURE: 5a

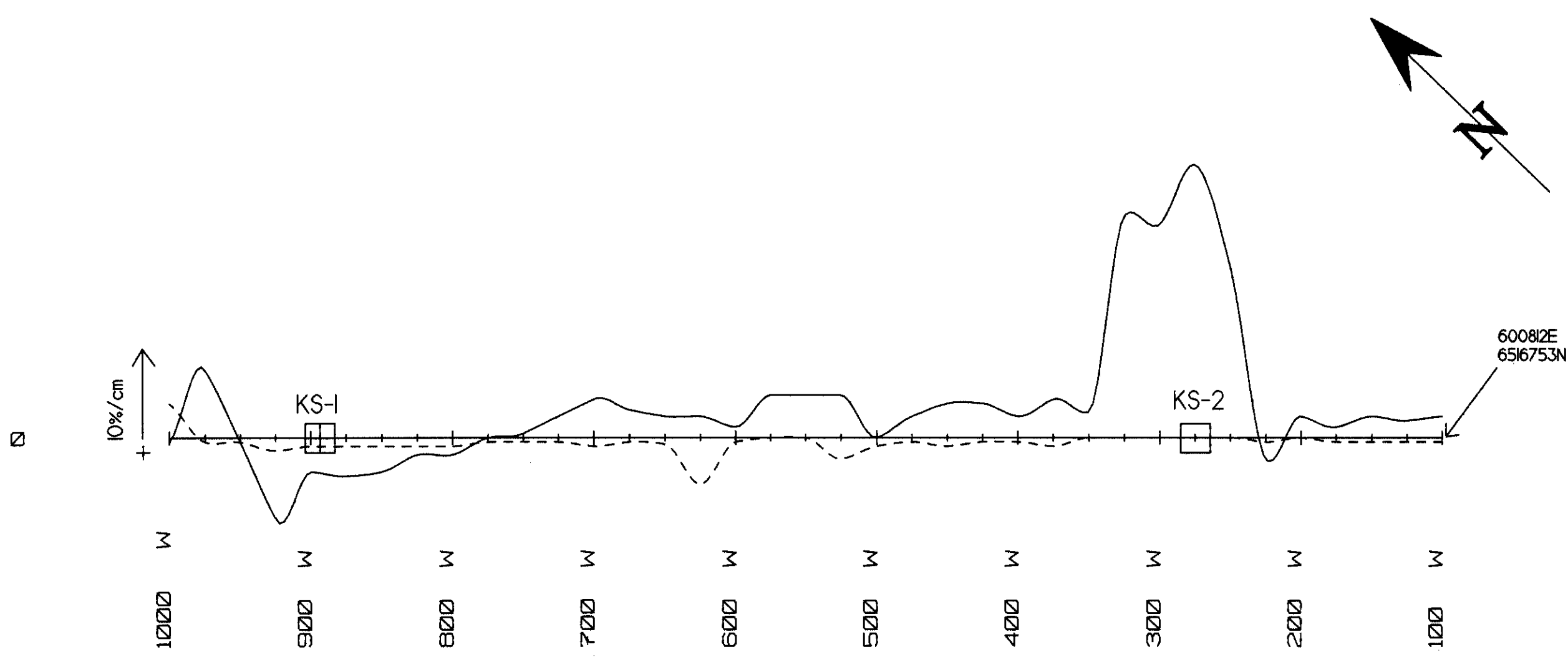

600812E
6516753N

CONDUCTANCE (222 & 3555 Hz)

- > 50 S
- 20 - 50 S
- 5 - 20 S
- 1 - 5 S
- < 1 S
- CONDUCTANCE UNKNOWN
- CONDUCTOR AXIS

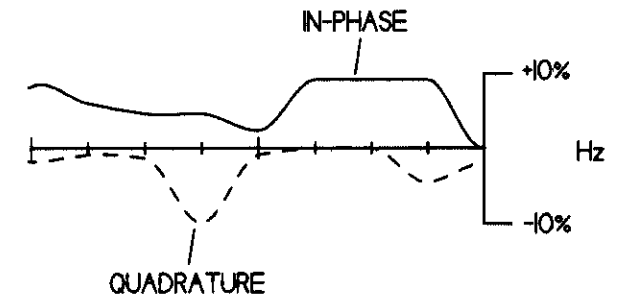
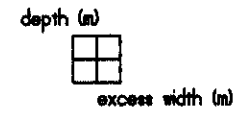

IN-PHASE - solid / QUADRATURE - dashed
VERTICAL SCALE: 10%/cm (positive upwards)



X-plorer Gold Corp.	RED CAP PROPERTY KING SALMON GRID
MAXMIN II SURVEY	CLAIMS: CAP 3
100m COILS - 222 Hz	NTS: 1:04 K/14 SCALE: 1:3000
AMEROK GEOSCIENCES LTD.	OPERATOR: C.L./R.S.
	DATE: 11 March 98 FIGURE: 5b

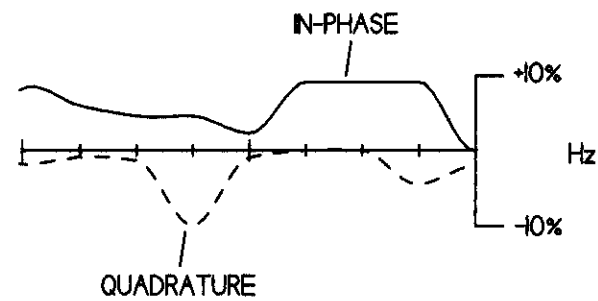
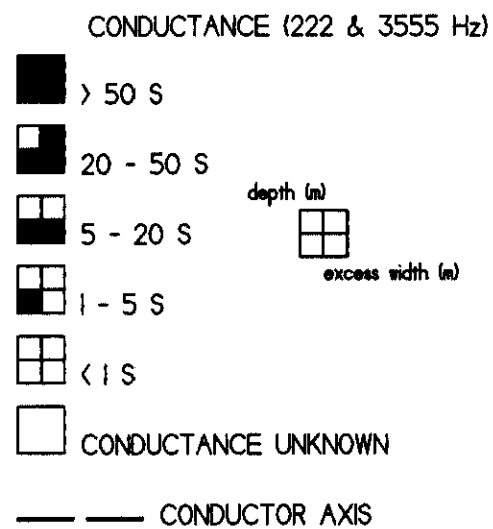
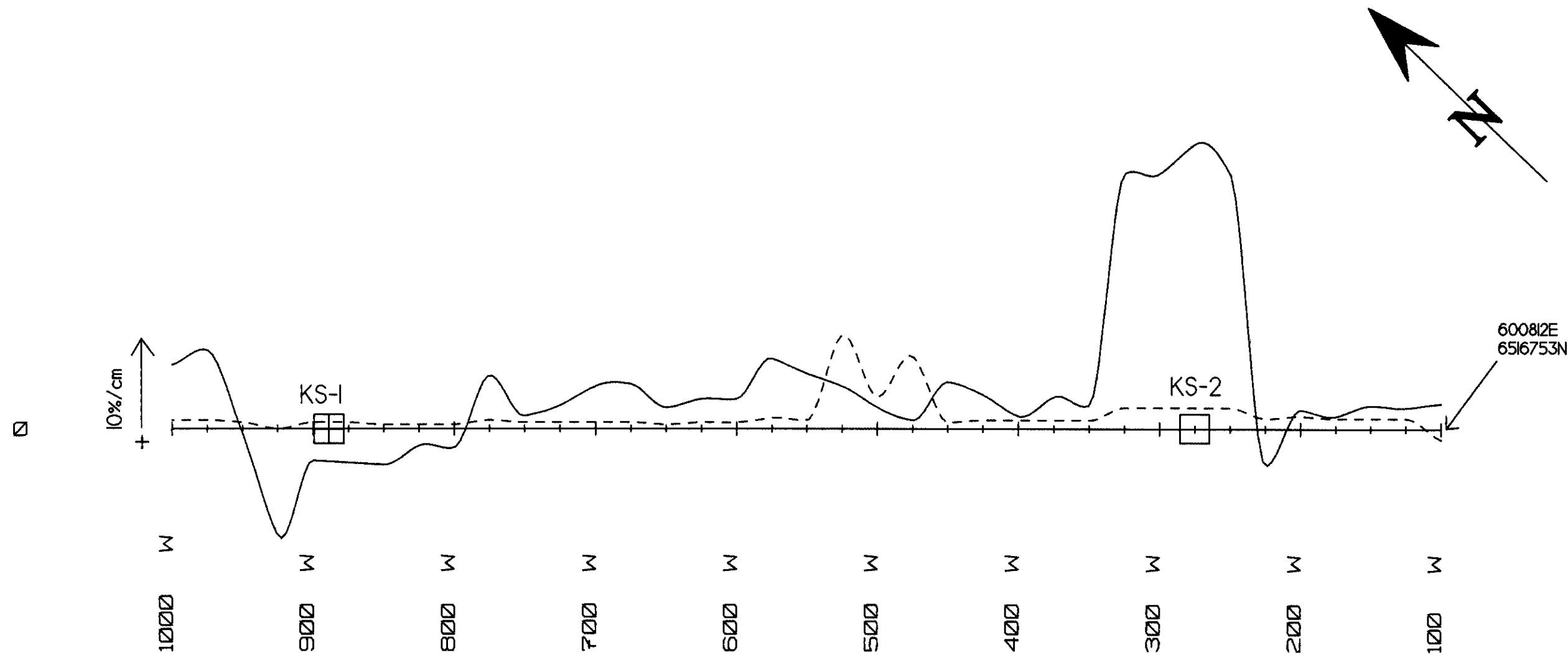

IN-PHASE - solid / QUADRATURE - dashed
 VERTICAL SCALE: 10%/cm (positive upwards)



X-plorer Gold Corp.	RED CAP PROPERTY KING SALMON GRID
MAXMIN II SURVEY 100m COILS - 888 Hz	CLAIMS: CAP 3
AMEROK GEOSCIENCES LTD.	NTS: 104 K/14 SCALE: 1:3000
	OPERATOR: C.L./R.S.
	DATE: 11 March 98
	FIGURE: 5c

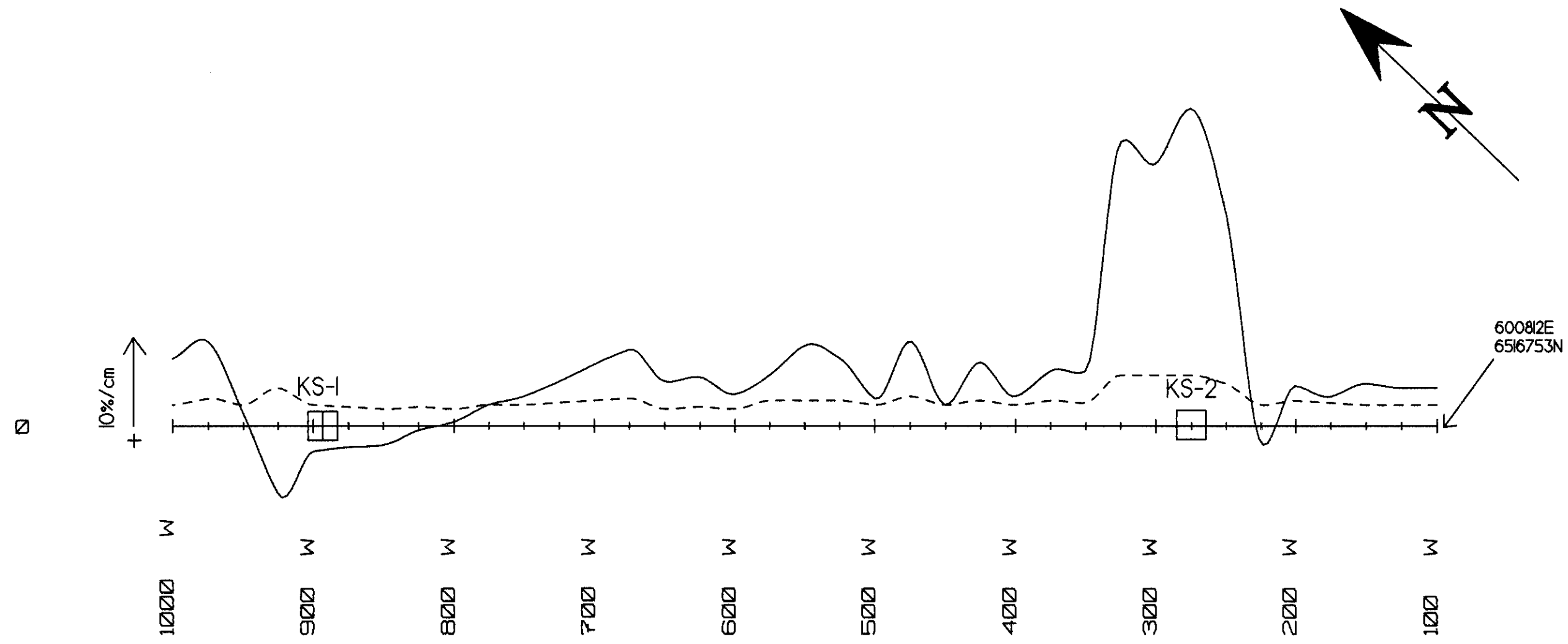

CONDUCTANCE (222 & 3555 Hz)

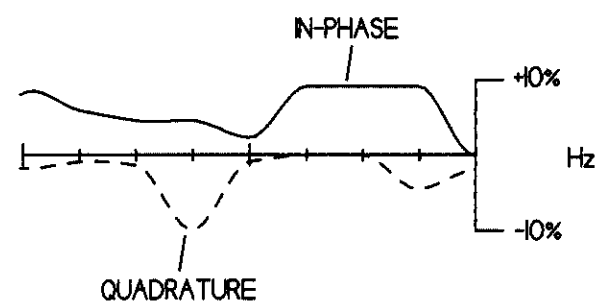
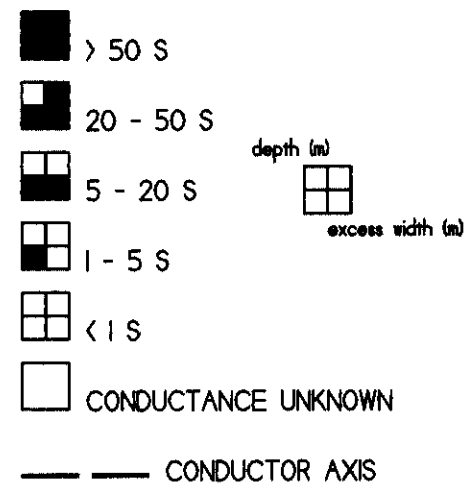

IN-PHASE - solid / QUADRATURE - dashed
 VERTICAL SCALE: 10%/cm (positive upwards)



X-plorer Gold Corp.	RED CAP PROPERTY KING SALMON GRID	
MAXMIN II SURVEY	CLAIMS: CAP 3	
100m COILS - 3555 Hz	NTS: 1:4 K/14	SCALE: 1:3000
AMEROK GEOSCIENCES LTD.	OPERATOR: C.L./R.S.	
	DATE: 11 March 98	FIGURE: 5d

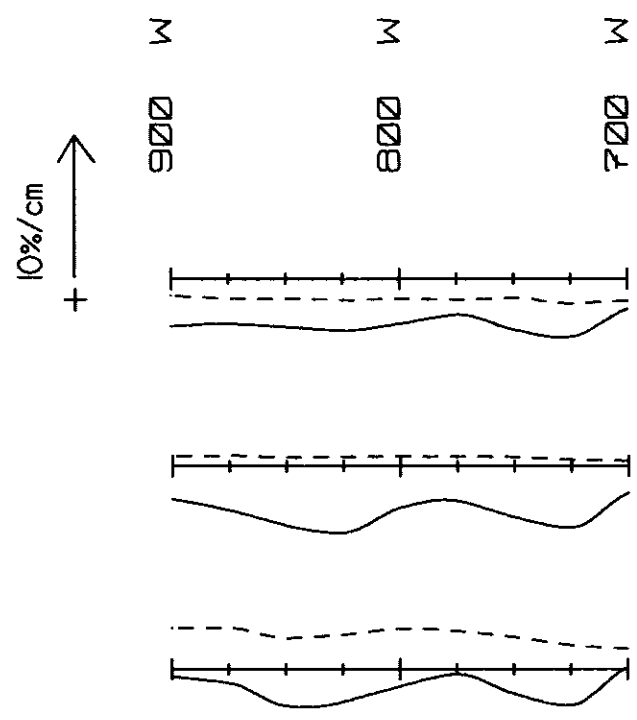
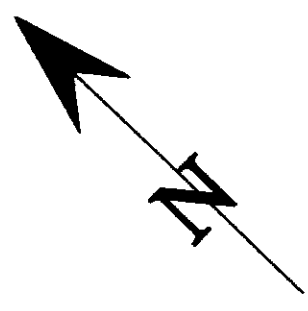

α-150m f-222 Hz

α-150m f-888 Hz

α-150m f-3555 Hz

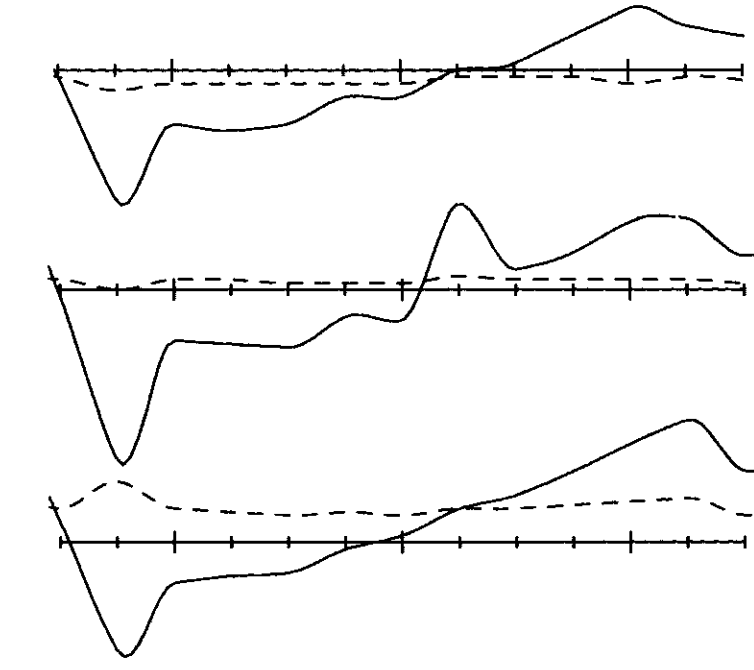

α-100m f-222 Hz

α-100m f-888 Hz

α-100m f-3555 Hz

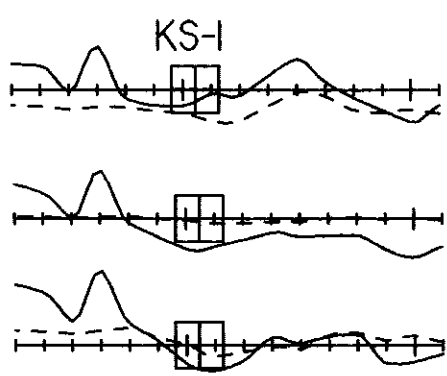

α-50m f-222 Hz

α-50m f-888 Hz

α-50m f-3555 Hz

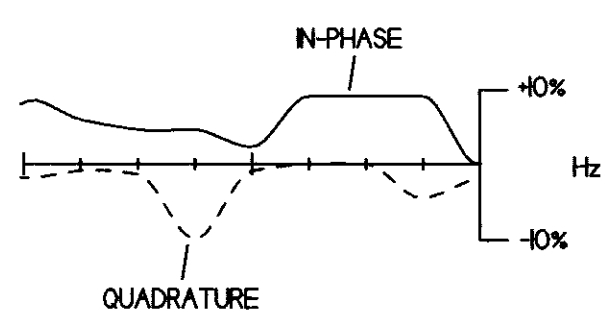

IN-PHASE - solid / QUADRATURE - dashed
 VERTICAL SCALE: 10%/cm (positive upwards)

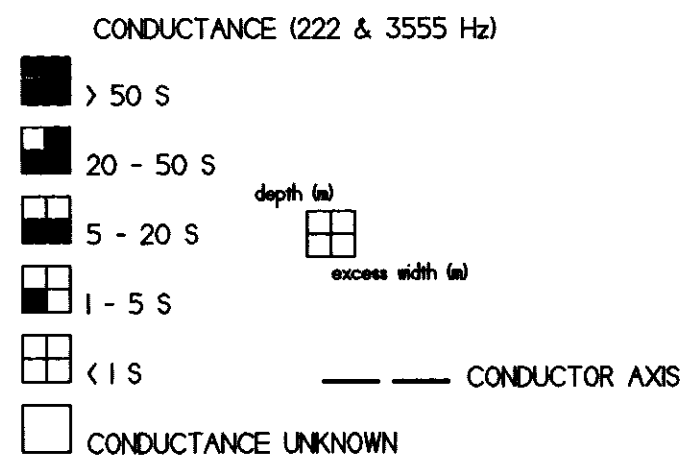

X-PLORER GOLD CORP.	RED CAP PROPERTY
COMPOSITE PROFILE LINE ON	KING SALMON GRID
	CLAIMS: CAP 3
	NTS: 105 K/14 SCALE: 1:3000
AMEROK GEOSCIENCES LTD.	OPERATOR: CL/R.S.
	DATE: 11 March 98 FIGURE: 5e