

EVENT # 4962947

A REPORT

ON

INDUCED POLARIZATION SURVEYING

Max-K2 Property
Fort St. James Area,
Omineca M.D. , B.C.
54° 56'N, 124° 02' W
NTS: 93N/16

Claims Surveyed: 532537, 532538 & 532540

Survey Dates: August 7th – 13th, September 23rd – October 14th, 2010

For

ANTHONY JAMES HEWETT

Vancouver, B.C.

BY

PETER E. WALCOTT & ASSOCIATES LIMITED

Vancouver, B.C.

JANUARY 2011

TABLE OF CONTENTS

	<u>Page</u>
Introduction	4
Property Location & Access	5
Previous Work	6
Geology	7
Purpose	8
Survey Specifications	9
Discussion of Results	12
Summary, Conclusions & Recommendations	14

APPENDIX

Cost of Survey	
Personnel Employed on Survey	
Certification	
Location Map	
Claim and Line Location Map	
Claim Location Map with Minfile Occurrences	
Regional Airborne Magnetics (GSC) with Minfile Occurrences	
Regional Airborne Radiometrics (GSC) eThK with Minfile Occurrences	
Regional Airborne Bouguer Gravity (GSC) eThK with Minfile Occurrences	

TABLE OF CONTENTS con't

<u>ACCOMPANYING MAPS</u>	<u>MAP POCKET</u>
IP Pseudo Sections Lines 31600E, 31800E, 32000E, 32200E, 32400E, 32600E, 32800E, 33000E	1:5,000
IP 2D Inversions 32000E, 32200E, 32400E, 32600E, 32800E, 33000E	1:5,000
Stacked Apparent Chargeability and Resistivity Sections	1:5,000
Contours of 3 nd separation apparent chargeability	1:10,000
Contours of 3 nd separation apparent resistivity	1:10,000
Geology (after W. Donaldson,1991)	1:10,000
Soil and Rock Geochemistry Copper	1:10,000
Soil and Rock Geochemistry Gold	1:10,000
Airborne Magnetic Survey – Contours of Total Field Magnetism	1:10,000
Airborne Magnetic Survey - Contours of Total Field Magnetism (1990)	1:10,000
Airborne Radiometric Survey - Contours of eTh/K	1:10,000

INTRODUCTION.

Between August 7th and 13th, 2010 Peter E. Walcott & Associates Limited undertook induced polarization (I.P.) surveying over parts of the Max-K2 property, located some 57 kilometres northeast of the settlement of Fort St. James, British Columbia, for Anthony Hewett.

The survey was carried out over four north-south lines which were established by the geophysical crew.

Unfortunately the survey was curtailed by a forest closure on August 13th due to high daytime temperatures, lack of precipitation and subsequent extreme fire hazard rating.

Measurements – first to sixth separation – of apparent chargeability – the I.P. response parameter – and resistivity were made on each of the line traverses using the pole – dipole technique with a 50 metre dipole.

In addition the elevations and horizontal locations of the line stations were measured using a Brunton altimeter and a Garmin 60 Csx GPS unit respectively.

Work was resumed on September 23rd with eight additional lines laid out to the south as dictated by the August results.

The lines were again established by the geophysical crew, and the IP surveying carried out using the same specifications as before. However due to budgetary considerations the survey had to be curtailed after surveying the six most westerly lines.

The I.P. data are presented as individual pseudo sections at a scale of 1:5,000. In addition the third separation data is presented in contour form at 1:10,000 on a plan map of the grid.

PROPERTY, LOCATION & ACCESS.

The Max-K2 property is located in the Omineca Mining Division of British Columbia some 57 kilometres northeast of the settlement of Fort St. James. It consists of the following claims:

Claim Name	Tenure #	Area (ha)	Aniversary
New Copper West	530480	464	August 14 th
Max Copper	532537	464	August 14 th
Max Copper 2	532538	465	August 14 th
Max Copper 3	532540	465	August 14 th
Max Copper 4	532541	446	August 14 th
Max Copper 5	532542	372	August 14 th
Max Copper 6	532543	335	August 14 th
Max Copper 7	532635	446	August 14 th
Max Copper 7	532638	223	August 14 th
Max Copper South	551895	465	August 14 th

Access to the property is readily obtainable by active and old mining roads off the Rainbow forest service road, which is in turn accessed from the Omineca mining road.

PREVIOUS WORK

Mineral exploration in the Omineca district rotated with placer gold prospecting in 1869 and with copper exploration commencing in 1969.

In 1986 United Pacific Gold Limited conducted geological mapping, prospecting and soil/rock sampling programmes on the property.

In 1990 United sold their interest to City Resources who entered into a joint venture agreement with Rio Algom Exploration, which saw the latter conduct an airborne VLF electromagnetic and magnetic survey over the property, followed by grid soil sampling and geological mapping of the central portion.

In 1991 further work consisting of mapping, soil sampling and reconnaissance induced polarization surveying was completed on the other parts of the property.

In 1993 the B.C. government conducted a low level airborne magnetic and radiometric survey over the property, a continuation of the 1991 Mt. Milligan survey – the Mt. Milligan deposit is located some 22 kilometres to the north.

In 2007 Standard Metals Exploration Ltd. conducted soil and silt geochemical surveys along with limited geological mapping.

For further information the reader is referred to the B.C. Ministry of Energy, Mines and Petroleum Reserves ARIS archive, and to reports held by the property owner.

GEOLOGY.

The properties are located within the Quesnel Trough – Quesnellia Terrane –, a Mesozoic island arc terrane juxtaposed against the ancestral North American continental margin.

The Quesnel Trough is bounded on the west by older rocks of the Cache Creek Terrane across the Pinchi Fault, and to the east across the Manson Fault by the Slide Mountain Terrane.

The property is underlain by rocks of the Watch Lake and Inzana formations of the Takla Group - augite pyric flows and pyroclastics - with small dykes of diorite and gabbro cutting the volcanics possibly causing hornfelsing.

Four phases of a dominantly monzonitic to dioritic intrusive, coeval with the Takla volcanics, are seen in outcroppings on the property. Similar rocks are found at Mt. Milligan.

Significant magnetite, pyrite, chalcopyrite and malachite have been noted in the intrusive rocks.

For the further information the reader is referred to the aforementioned reports held by the property owner, and in particular to one of August 2010 by D. E. Blann, P.Eng. of Standard Metals Exploration Ltd.

PURPOSE.

The general purpose of the survey was to aid in the exploration for porphyry gold-copper mineralization of similar type to the Mt Milligan deposit. This type occurs associated with diorite, monzodiorite and syenite plugs and stocks and coeval andesitic volcanic rocks of the Takla Group and are generally associated with strong airborne magnetic anomalies and large copper-gold stream sediment anomalies.

SURVEY SPECIFICATIONS.

The Induced Polarization Survey.

The induced polarization (I.P.) survey was conducted using a pulse type system, the principal components of which were manufactured by Hunttec Limited of Metropolitan Toronto, Canada and Iris Instruments of Orleans, France.

The system consists basically of three units, a receiver (Iris), transmitter (Hunttec) and a motor generator (Hunttec). The transmitter, which provides a maximum of 7.5 kw d.c. to the ground, obtains its power from a 7.5 kw 400 c.p.s. three phase alternator driven by a Honda 20 h.p. gasoline engine. The cycling rate of the transmitter is 2 seconds “current-on” and 2 seconds “current-off” with the pulses reversing continuously in polarity. The data recorded in the field consists of careful measurements of the current (I) in amperes flowing through the current electrodes C_1 and C_2 , the primary voltages (V) appearing between any two sequential potential electrodes, P_1 through P_{n+1} , during the “current-on” part of the cycle, and the apparent chargeability, (M_a) presented as a direct readout in millivolts per volt using a 200 millisecond delay and a 1000 millisecond sample window by the receiver, a digital receiver controlled by a micro-processor – the sample window is actually the total of ten individual windows of 100 millisecond widths.

The apparent resistivity (ρ_a) in ohm metres is proportional to the ratio of the primary voltage and the measured current, the proportionality factor depending on the geometry

of the array used. The chargeability and resistivity are called apparent as they are values which that portion of the earth sampled would have if it were homogeneous. As the earth sampled is usually inhomogeneous the calculated apparent chargeability and resistivity are functions of the actual chargeability and resistivity of the rocks.

The survey was carried out using the “pole-dipole” method of surveying. In this method the current electrode, C_1 , and the potential electrodes, P_1 through P_{n+1} , are moved in unison along the survey lines at a spacing of “a” (the dipole) apart, while the second current electrode, C_2 , is kept constant at “infinity”. The distance, “na” between C_1 and the

SURVEY SPECIFICATIONS cont'd

nearest potential electrode generally controls the depth to be explored by the particular separation, “n”, traverse.

On this survey 50 metre dipoles were employed and first to sixth separation readings were obtained. In all some 20.5 kilometres of I.P. traversing were completed.

Vertical control.

The elevations of the stations were recorded using an ADC Summit altimeter manufactured by Brunton of Wyoming, USA. This instrument measures elevations using barometric pressures to an accuracy of plus or minus 3 metres. Corrections for errors due to variations in atmospheric pressure were made by comparison to readings obtained on a similar instrument, held stationary at one location – the base -, at 10 minute intervals.

Horizontal control.

The horizontal position of the stations were recorded using an WAAS equipped Thales Mobile Mapper L-1 phase GPS receiver.

Data Presentation.

The I.P. data are presented as individual pseudo section plots of apparent chargeability and resistivity at a scale of 1:5,000. Plots of the 21 point moving filter – illustrated on the pseudo section – for the above are also displayed in the top window to better show the location of the anomalous zones.

The anomalous chargeability zones are outlined on the respective pseudo sections.

SURVEY SPECIFICATION cont'd.

The third separation readings of chargeability and resistivity are shown in contour form on a plan map of the grid at a scale of 1:10,000 for comparison with the magnetics.

Two dimensional smooth model inversion of the resistivity and chargeability was carried out using the Geotomo RES2DINV Algorithm, an algorithm developed by Loke et-al. This algorithm uses a 2-D finite element method and incorporates topography in modeling resistivity and I.P. data. Nearly uniform starting models are generated by running broad moving-average filters over the respective lines of data. Model resistivity and chargeability properties are then adjusted iteratively until the calculated data values match the observed as closely as possible, given constraints which keep the model section smooth. The smooth chargeability and resistivity models were then imported into Geosoft format for presentation at the same scale of 1:5,000 on the topographic profile. A slight discrepancy can be observed between the measured and modeled plots as the former are processed in Geosoft which assumes horizontal distances for the station separation.

DISCUSSION OF RESULTS.

The government airborne magnetic survey shows a large elliptical like high in the southeastern portion of the property linked by higher magnetics to a similar but circular high to the southwest just off the property. These presumably relate to a more magnetic phase in the postulated underlying intrusive.

A narrower elongate northwesterly more moderate high can be seen extending northwest from the Goldpan Creek showing.

A high potassium (K) count is seen on the airborne radiometrics trending northeasterly through the larger magnetic feature, and when combined with a similarly trending equivalent thorium low gives rise to large eTh/K low north of the magnetic feature.

As the same rock types have been mapped on the property as at the Mt. Milligan deposit the writer has included the GSC 2004 magnetic and radiometric – eTh/K – maps of the area as well as the Quest airborne gravity results showing the geophysical similarities.

The limited induced polarization showed the property to exhibit a low chargeability background – 4 to 6 mV/V – above which several areas of elevated chargeability response are discernible on the respective pseudosections, inverted sections and the contoured chargeability plan.

Within the survey area, the three dominant zones of elevated chargeability, located within anomalous geochemistry and eTh/K lows, are shown on the plan map of the third separation chargeability and are described below.

Anomaly cA is situated in the northern portion of the grid, just north of station 88+500N on lines 32+200E – 32+600E. It is a moderate to high chargeability feature associated with a high resistivity and a moderate copper soil anomaly. This anomaly is situated on the eastern flank of a magnetic high as defined by the 1990 Rio Algom airborne magnetic survey.

DISCUSSION OF RESULTS con't.

Anomaly cB is situated in the central portion of the grid between stations 875+00N and 88+200 N. This large chargeability feature is associated with a resistivity high, which decreases somewhat to the east, a pronounced eTh/K low, along with very anomalous gold and copper values. This anomaly remains open to both the east and west and is situated on an east-northeasterly break, which can be discerned in both the airborne TMI and contoured soil geochemistry. A marked break in the resistivity can also be observed trending NNE, which is also associated with the terminus of the chargeability anomaly to the north. This anomaly is of significant interest, and additional IP surveying should be carried out on lines to the east and west to properly delineate the anomaly prior to contemplating drilling.

Anomaly cC is situated in the southwestern portion of the grid between stations 86+500N and 87+100N on lines 32+000E to 32+400E. The anomaly is of moderate to high chargeability increasing in size and intensity towards the west, associated with a moderate resistivity. This feature is within the airborne magnetic high and the eTh/K low, and lies just north of a high copper anomaly. This feature remains undefined to the west and south. Further surveying should be done on lines extended to encompass both the soil and radiometric anomalies. A larger a-spacing – dipole - should also be employed to the east to test for a deeper chargeability feature which can be observed on the neighboring lines on both the respective pseudosections and inverted sections.

It should be mentioned here that while attempts were made to use the 1990 Aerodat magnetic data flown for Rio Algom Exploration, these proved to be somewhat limited given the b/w map. If possible efforts should be made to acquire the digital data or digitize the existing map as the detailed magnetics would prove useful.

SUMMARY, CONCLUSIONS & RECOMMENDATIONS

Between August 7th and 13th, 2010 Peter E. Walcott and Associates Limited undertook induced polarization traversing over parts of the Max-K2 property for Anthony Hewett.

The property is located 6 kilometers north northeast of Cripple Lake on the Germansen-Cripple Lake road, and some 57 kilometres northeast of Fort St. James.

The survey was carried out over four north south trending lines, established by the geophysical crew.

Unfortunately the crew had to leave the property before completing the proposed work due to an order to cease operations in the bush occasioned by extreme temperatures and tinder dry conditions.

The crew returned to the property on September 23rd and established six new similarly trending lines to the south of the August work, the most westerly two of which were southward extensions of the previous two most easterly. They completed surveying of these lines by October 14th, 2010.

Three discrete chargeability zones can be observed coincident with copper-gold geochemical anomalies and the thorium-potassium low as a result of the joint surveys. These were only partially delineated as per previously mentioned.

Thus the writer recommends that the IP coverage be extended in order to properly outline these and other additional chargeability features within the large anomalous geochemical /eTh/K area. Additionally magnetic surveying should be undertaken on the grid as it could prove useful in delineating structures and/or potential alteration zones within the aforementioned area.

SUMMARY, CONCLUSIONS & RECOMMENDATIONS cont'd.

Some 30 kilometres of additional IP/Magnetics would be required to sufficiently cover the anomalous zones, and eTh/K anomaly.

The resulting data should then be compiled with the existing geochemical and geological data in order to determine the best targets for investigation by diamond drilling.

Respectfully submitted,

PETER E. WALCOTT & ASSOCIATES LIMITED

**Peter E. Walcott, P.Eng.
Geophysicist**

**Vancouver, B.C.
January 2011**

APPENDIX

COST OF SURVEY.

Peter E. Walcott & Associates Limited undertook the survey on a daily basis, providing a seven man crew, I.P. equipment, altimeters, GPS unit, chain saws and ancillary line cutting equipment, and two trucks at a per diem rate of \$3,500.00 on the August survey, and a six man crew on the September-October survey at \$3,200.00 per day. The linecutting was performed at \$1,825.00 per day on the latter. Mobilization costs of \$8,000.00 and \$5,000.00 were incurred respectively for the two surveys while accommodation and fuel were billed at \$15,599.10 for both. Reporting costs of \$3,750.00 were applied so that the total costs for the completed surveying to date were \$97,350.00.

PERSONNEL EMPLOYED ON SURVEY.

<u>Name</u>	<u>Occupation</u>	<u>Address</u>	<u>Dates</u>
Peter E. Walcott	Geophysicist	Peter E. Walcott & Associates Limited 608 – 1529 W. 2 nd Ave., Vancouver, B.C. V6J 1H2	Nov. 8 th & 9 th .10 Jan. 8 th & 24 th , 11
Alexander Walcott	“	“	Aug 17 th - 18 th , 2010 Jan. 8 th – 12 th , 2011
John Cornock	"	"	Aug. 7 th -13 th , 2010
M. Magee	Geophysical Operator	"	Aug. 7 th -13 th , Sept. 23 rd - Oct 13 th , 2010
J. Kolcun	“	"	Aug. 7 th -13 th , 2010
S. Oliver	Geophysical Assistant	“	“
G. Prince	"	"	"
C. Prince	"	"	Aug. 7 th -13 th , Oct. 4 th – 13 th , 2010
R. Comeau	"	"	Sept 26 th – Oct 3 rd , 2010
O. Janout	“	“	Oct 3 rd – 14 th , 2010

PERSONNEL EMPLOYED ON SURVEY cont'd.

P. Charlie	Geophysical Operator	"	Sept. 23 rd - Oct 14 th , 2010
T. Harpley	Geophysical Assistant	"	"
S. Lessard	"	"	Sept. 23 rd - Oct 13 th , 2010

CERTIFICATION.

I, Peter E. Walcott of 605 Rutland Court, Coquitlam, British Columbia, hereby certify that:

1. I am a graduate of the University of Toronto in 1962 with a B.A.Sc. in Engineering Physics, Geophysics Option.
2. I have been practicing my profession for the last forty eight years.
3. I am a member of the Association of Professional Engineers of British Columbia and Ontario.
4. I hold no interest, direct or indirect in the properties of Anthony Hewett, nor do I expect to receive any.

Peter E. Walcott, P.Eng.

**Vancouver, B.C.
January 2011**

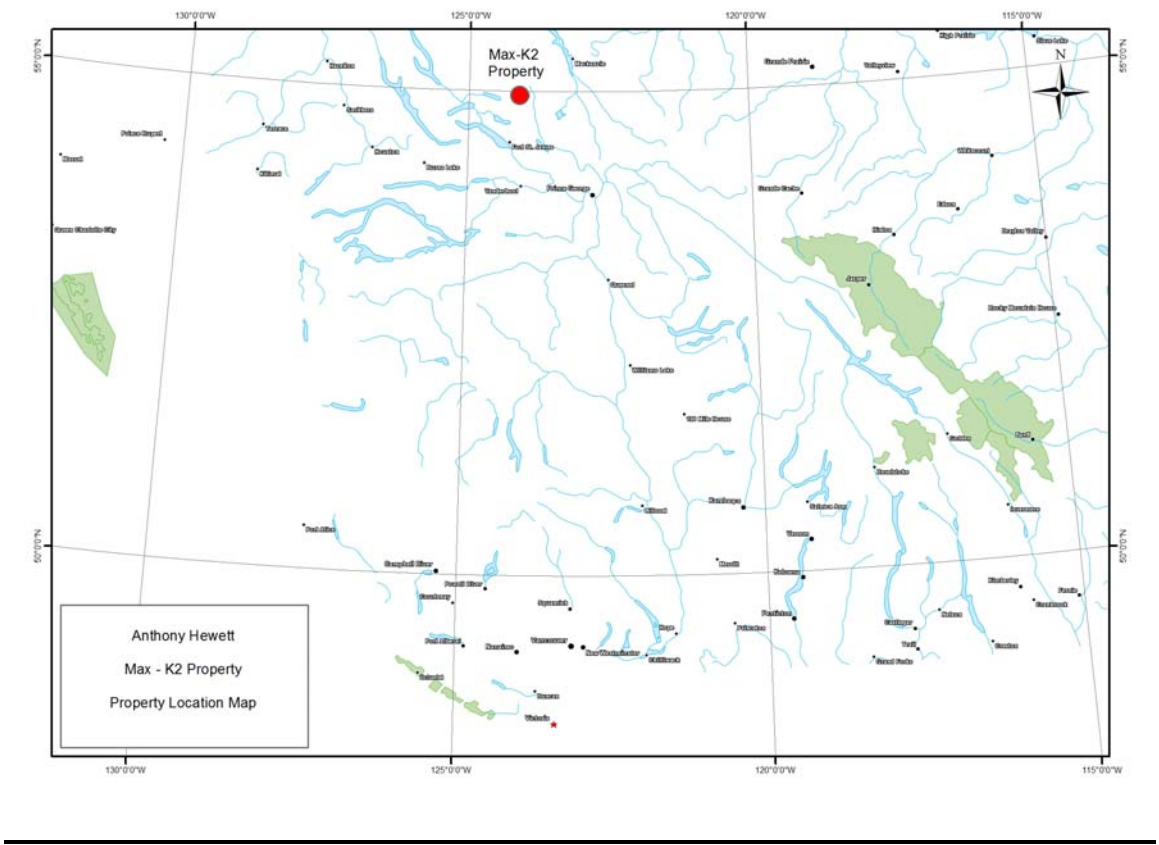

Property Location Map

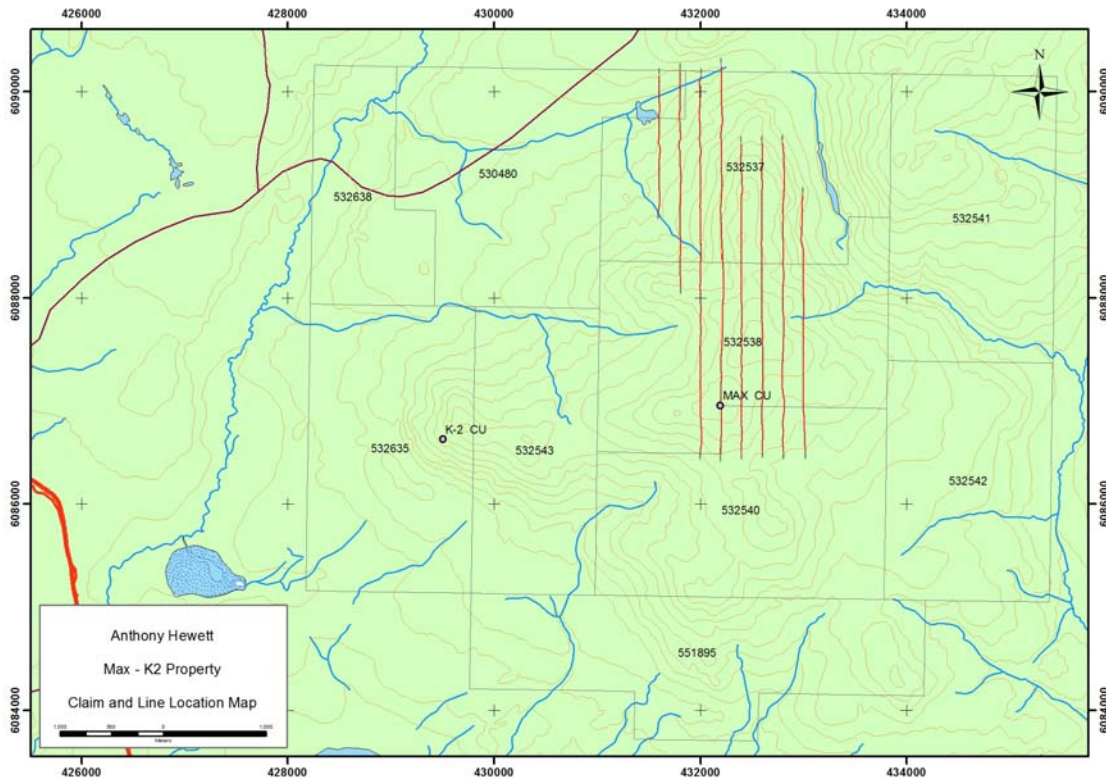

Claim and Line Location Map

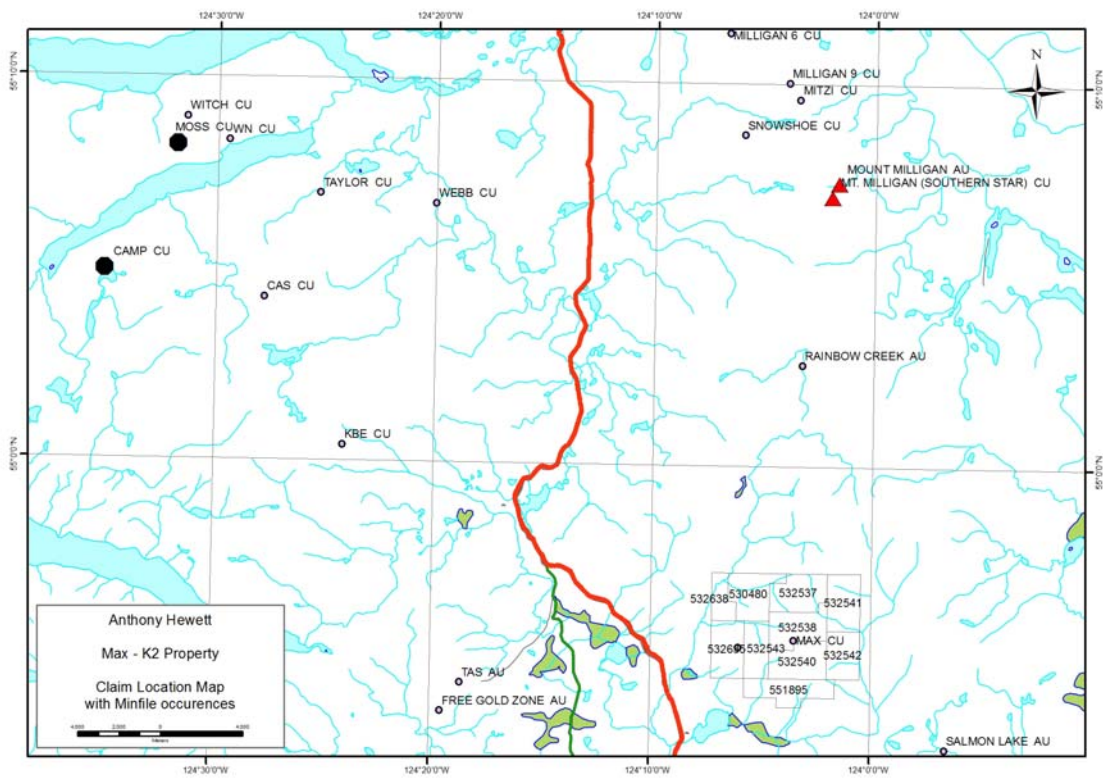

Claim Location Map with Minfile Occurrences

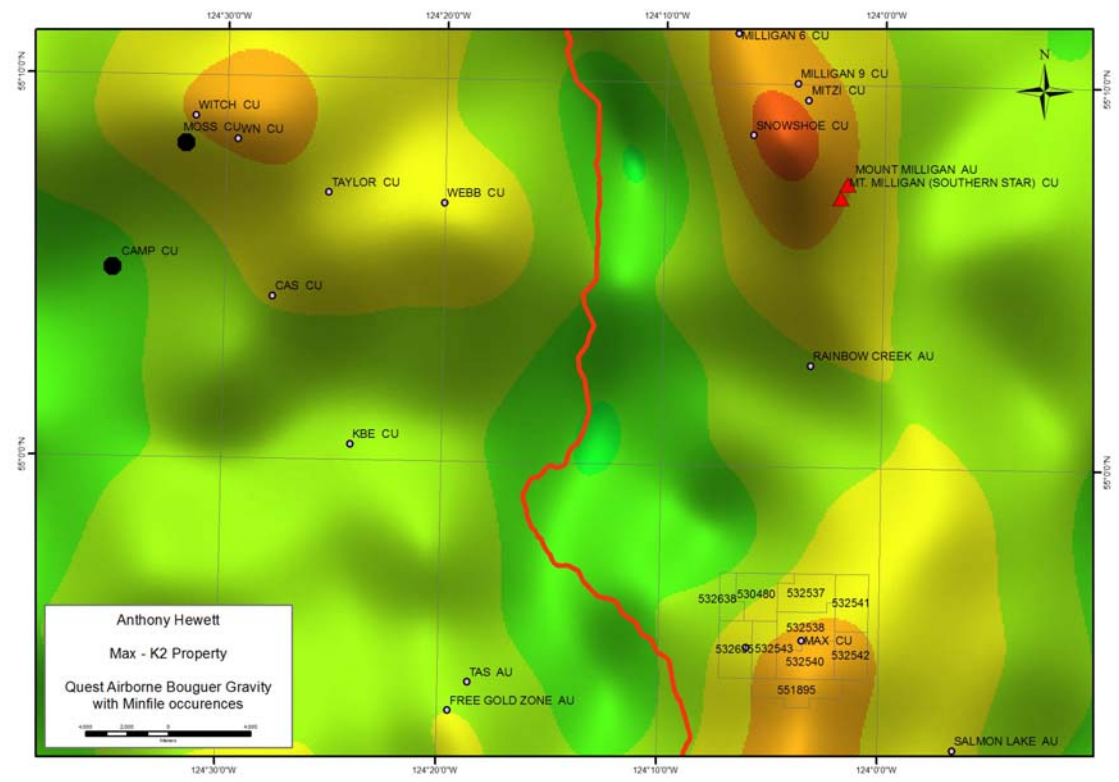

Quest Airborne Bouguer Gravity with Minfile Occurrences

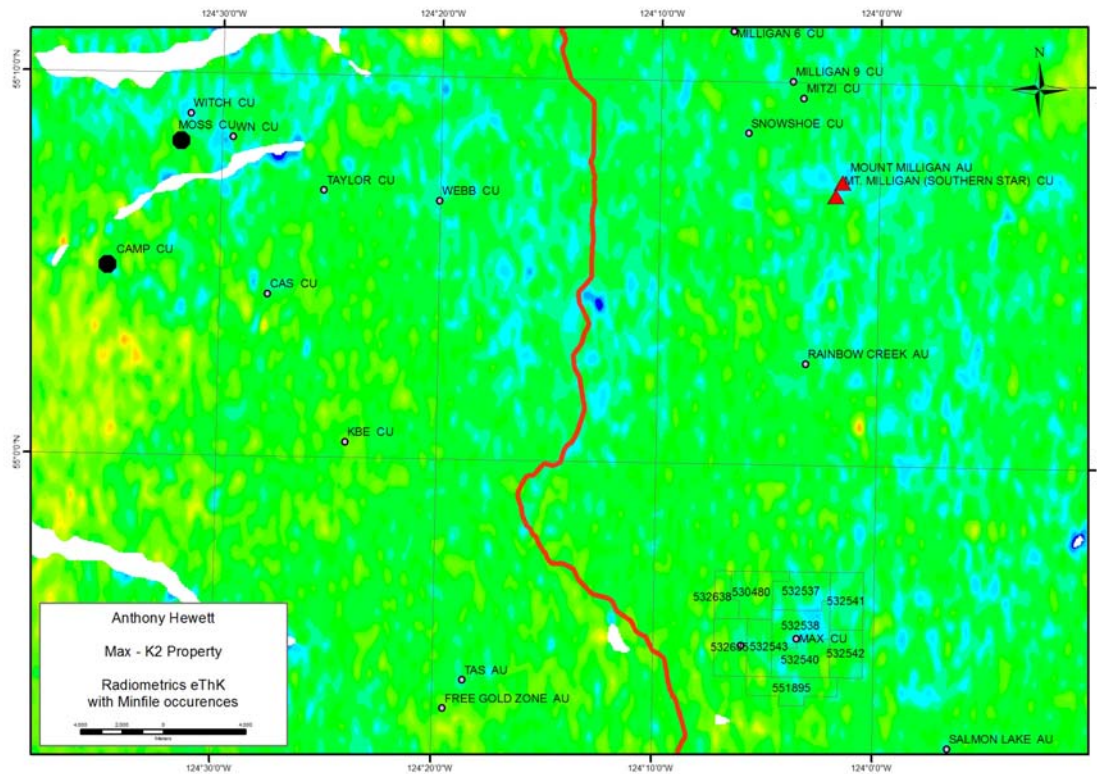

Radiometrics eTHK with Minfile Occurrences

Dipole-Pole Array

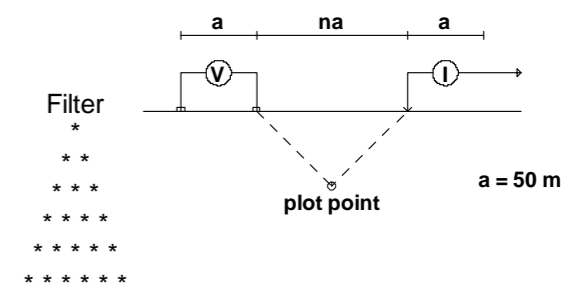





Instruments: Walcer 9.0kw Tx, Iris Pro Rx

Frequency: 0.125 Hz. Mdly 200ms 20*50ms Windows
Operators: M.M., P.C.

Logarithmic Contours: 1.5, 2, 3, 5, 7.5, 10,...

INTERPRETATION

-  Well defined, strong increase in polarization with or without marked decrease in resistivity.
-  Fairly well defined moderate increase in polarization.
-  Fairly well defined weak increase in polarization.
-  Resistivity feature.

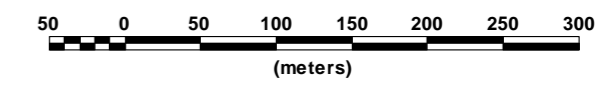

HEWETT

INDUCED POLARIZATION SURVEY
MAX K2 PROPERTY

Date: SEPTEMBER 2010

PETER E. WALCOTT & ASSOCIATES LIMITED

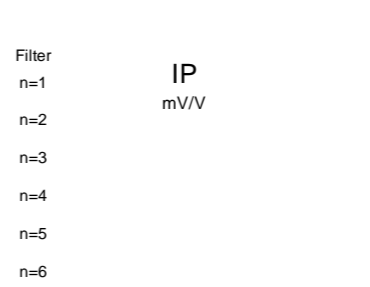
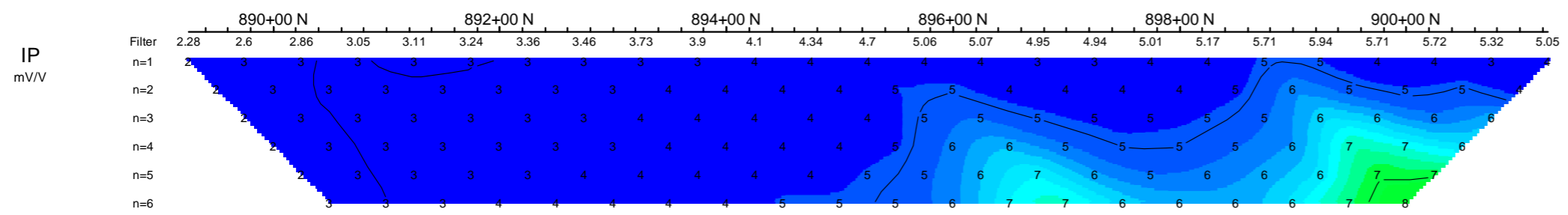
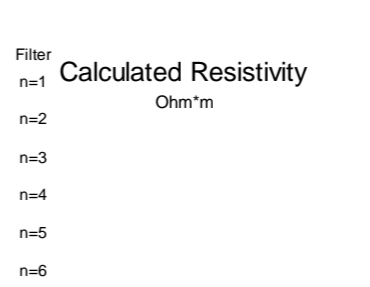
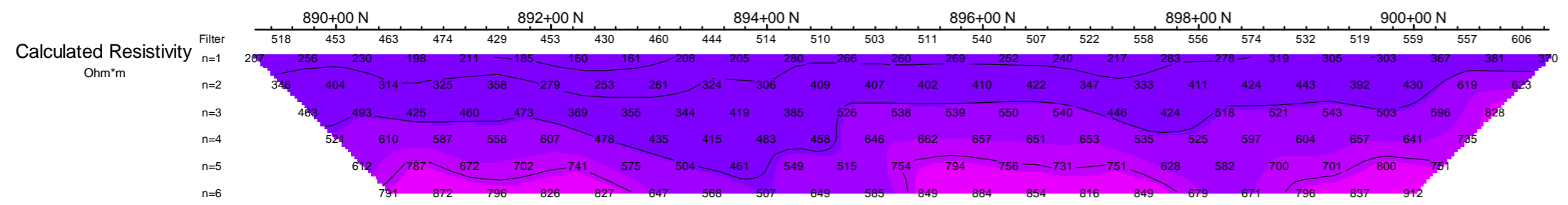
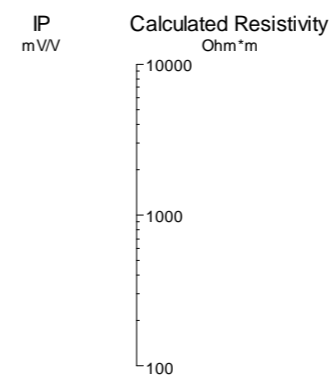
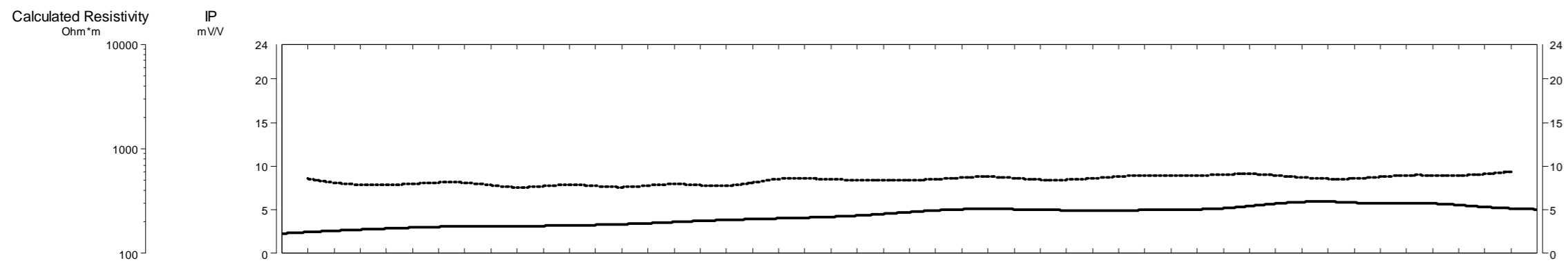

Dipole-Pole Array

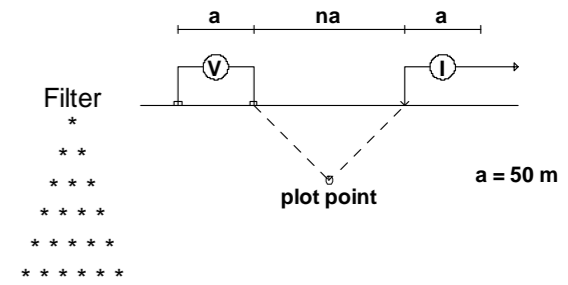

Instruments: Walcer 9.0kw Tx, Iris Pro Rx
 Frequency: 0.125 Hz. Mdly 200ms 20*50ms Windows
 Operators: M.M., P.C.
 Logarithmic Contours
 1, 1.5, 2, 3, 5, 7.5, 10,...

INTERPRETATION

- Well defined, strong increase in polarization with or without marked decrease in resistivity.
- Fairly well defined moderate increase in polarization.
- Fairly well defined weak increase in polarization.
- Resistivity feature.

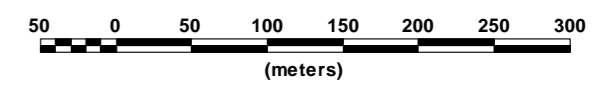

HEWETT
 INDUCED POLARIZATION SURVEY
 MAX K2 PROPERTY
 Date: SEPTEMBER 2010
 PETER E. WALCOTT & ASSOCIATES LIMITED

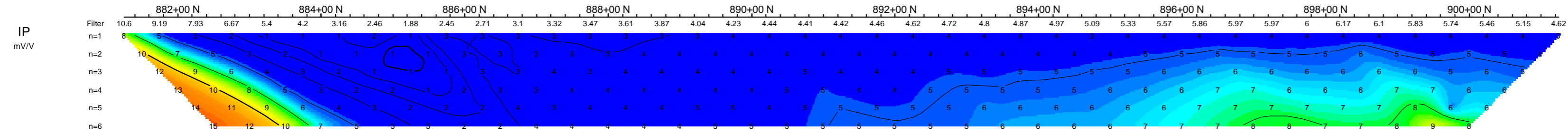
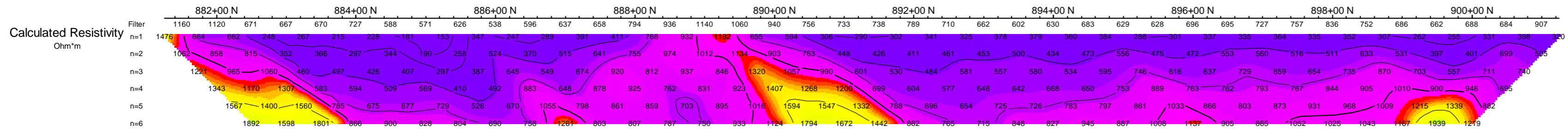
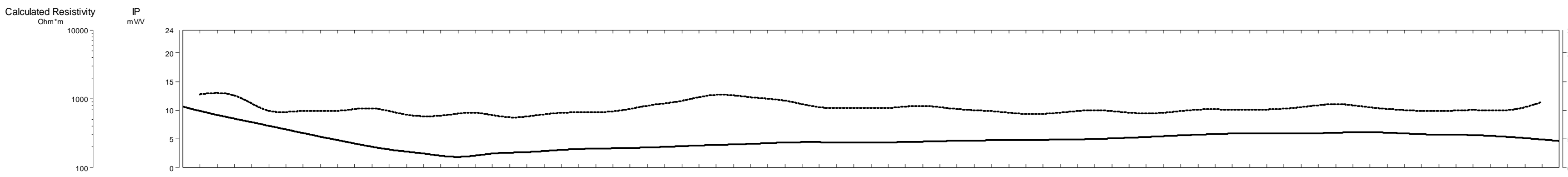

320+00 E

Dipole-Pole Array

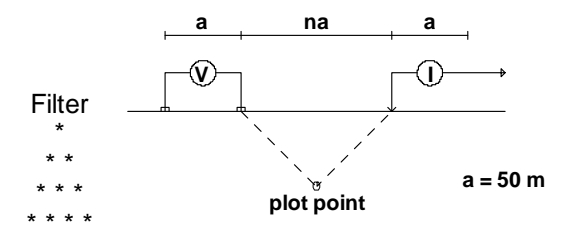

Instruments: Walcer 9.0kw Tx, Iris Pro Rx

Frequency: 0.125 Hz. Mdlly 200ms 20*50ms Windows
Operators: M.M., P.C.

Logarithmic Contours: 1.5, 2, 3, 5, 7.5, 10, ...

INTERPRETATION

- Well defined, strong increase in polarization with or without marked decrease in resistivity.
- Fairly well defined moderate increase in polarization.
- Fairly well defined weak increase in polarization.
- Resistivity feature.

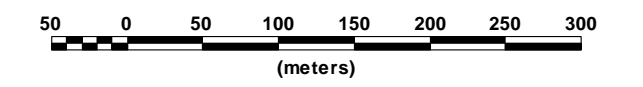

HEWETT
INDUCED POLARIZATION SURVEY
MAX K2 PROPERTY
Date: SEPTEMBER 2010
PETER E. WALCOTT & ASSOCIATES LIMITED

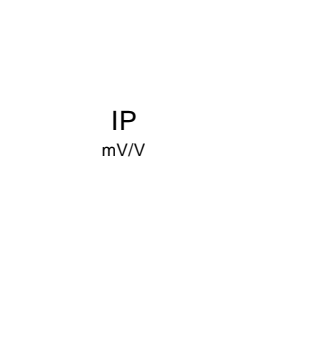
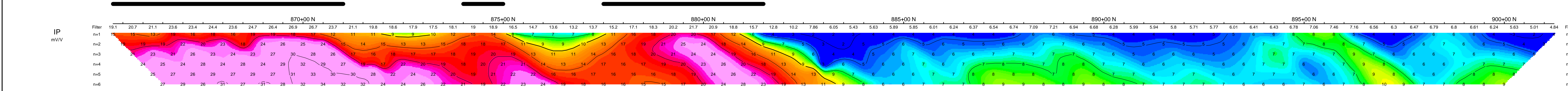
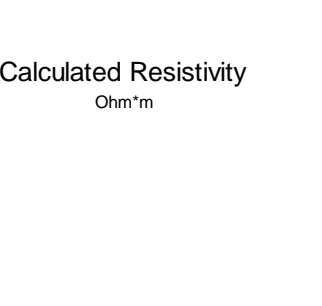
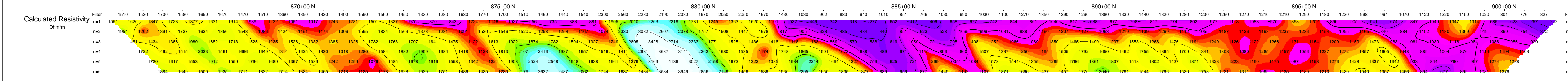
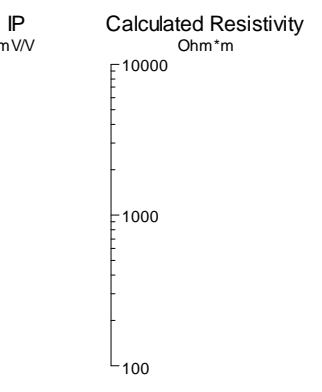
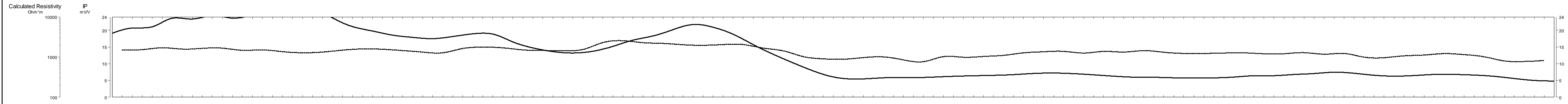

322+00 E

Dipole-Pole Array

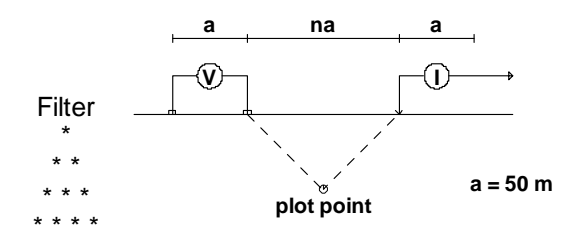

Instruments: Walcer 9.0kw Tx, Iris Pro Rx

Frequency: 0.125 Hz. Mdlly 200ms 20*50ms Windows
Operators: M.M., P.C.

Logarithmic Contours: 1.5, 2, 3, 5, 7.5, 10, ...

INTERPRETATION

- Well defined, strong increase in polarization with or without marked decrease in resistivity.
- Fairly well defined moderate increase in polarization.
- Fairly well defined weak increase in polarization.
- Resistivity feature.

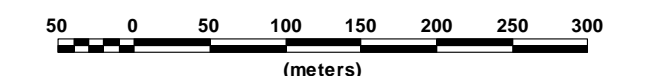

HEWETT
INDUCED POLARIZATION SURVEY
MAX K2 PROPERTY
Date: SEPTEMBER 2010
PETER E. WALCOTT & ASSOCIATES LIMITED

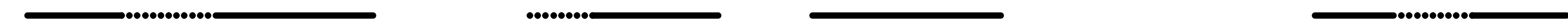
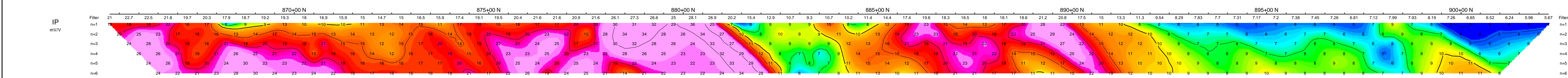
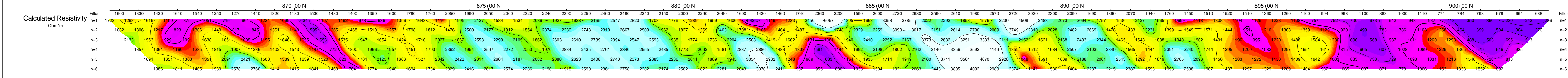
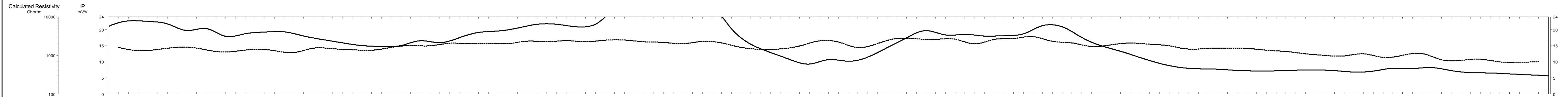

Dipole-Dipole Array

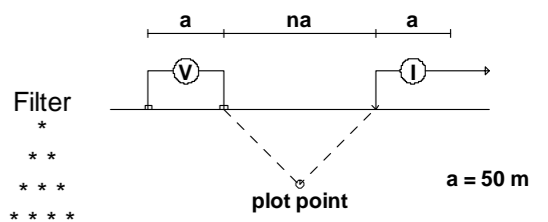

Instruments: Walcer 9.0kw Tx, Iris Pro Rx

Frequency: 0.125 Hz. Mdlly 200ms 20*50ms Windows
Operators: M.M., P.C.

Logarithmic Contours: 1.5, 2, 3, 5, 7.5, 10,...

INTERPRETATION

- Well defined, strong increase in polarization with or without marked decrease in resistivity.
- Fairly well defined moderate increase in polarization.
- Fairly well defined weak increase in polarization.
- Resistivity feature.

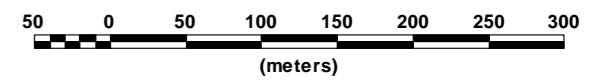

HEWETT
INDUCED POLARIZATION SURVEY
MAX K2 PROPERTY
Date: SEPTEMBER 2010
PETER E. WALCOTT & ASSOCIATES LIMITED

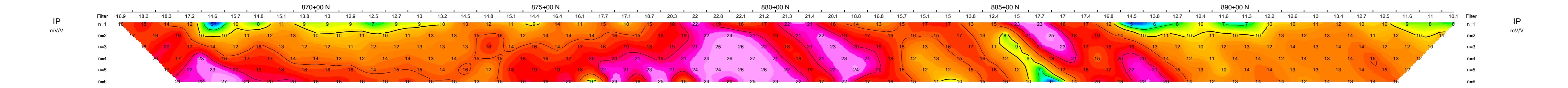
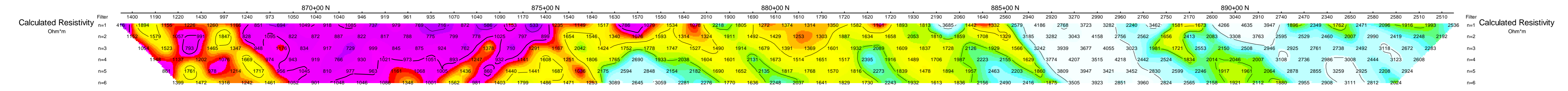
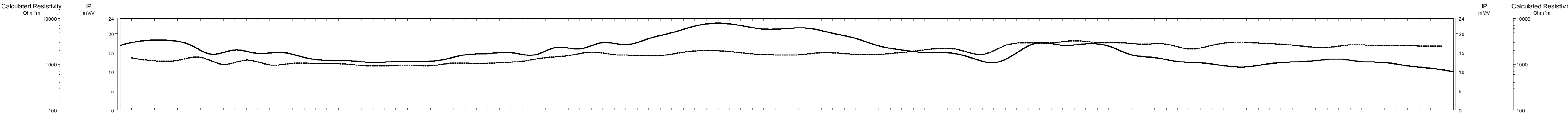

326+00 E

Dipole-Dipole Array

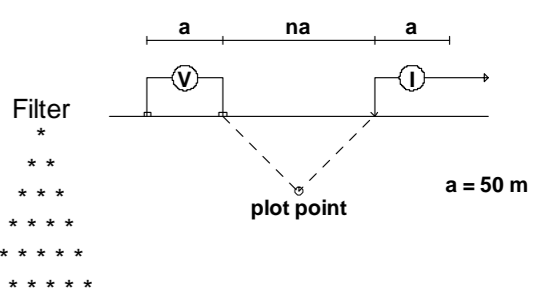





Instruments: Walcer 9.0kw Tx, Iris Pro Rx

Frequency: 0.125 Hz. Mdly 200ms 20*50ms Windows
Operators: M.M., P.C.

Logarithmic Contours: 1, 1.5, 2, 3, 5, 7.5, 10, ...

INTERPRETATION

-  Well defined, strong increase in polarization with or without marked decrease in resistivity.
-  Fairly well defined moderate increase in polarization.
-  Fairly well defined weak increase in polarization.
-  Resistivity feature.

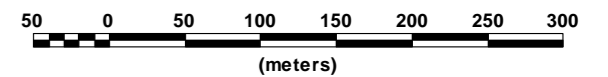

HEWETT
INDUCED POLARIZATION SURVEY
MAX K2 PROPERTY
Date: SEPTEMBER 2010
PETER E. WALCOTT & ASSOCIATES LIMITED

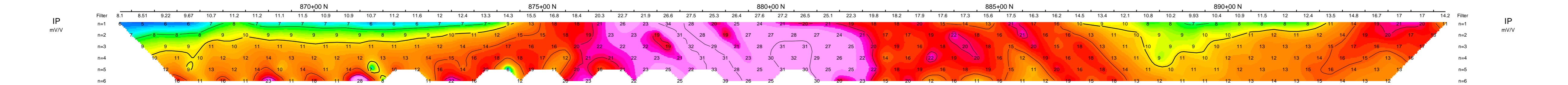
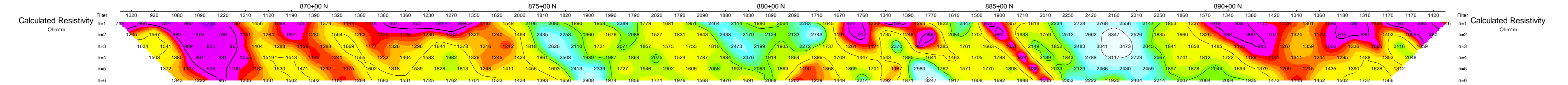
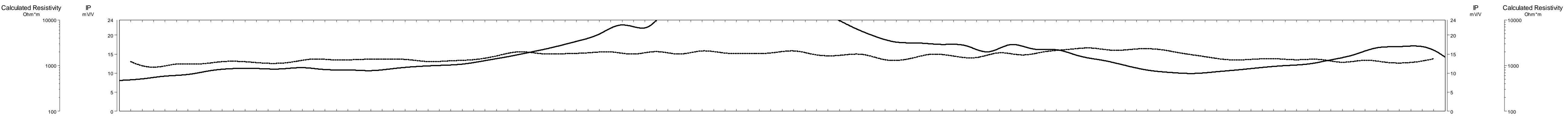

328+00 E

Dipole-Dipole Array

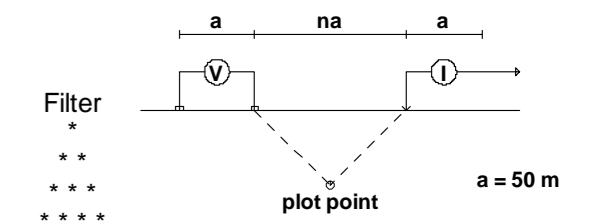

Instruments: Walcer 9.0kw Tx, Iris Pro Rx

Frequency: 0.125 Hz. Mdly 200ms 20*50ms Windows
Operators: M.M., P.C.

Logarithmic
Contours 1, 1.5, 2, 3, 5, 7.5, 10,...

INTERPRETATION

- Well defined, strong increase in polarization with or without marked decrease in resistivity.
- Fairly well defined moderate increase in polarization.
- Fairly well defined weak increase in polarization.
- Resistivity feature.

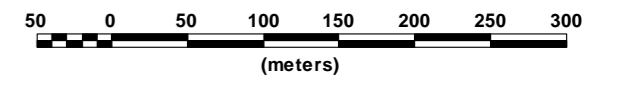

HEWETT
INDUCED POLARIZATION SURVEY
MAX K2 PROPERTY
Date: SEPTEMBER 2010
PETER E. WALCOTT & ASSOCIATES LIMITED

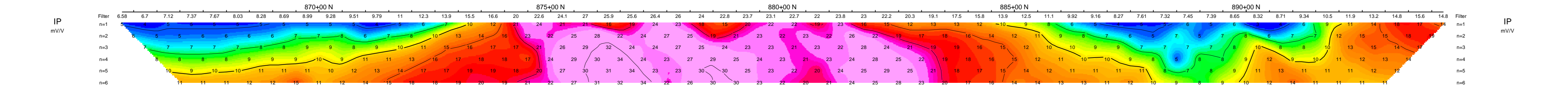
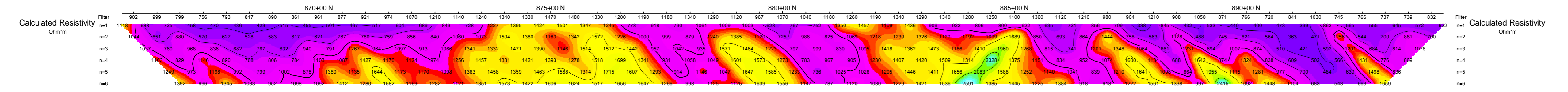
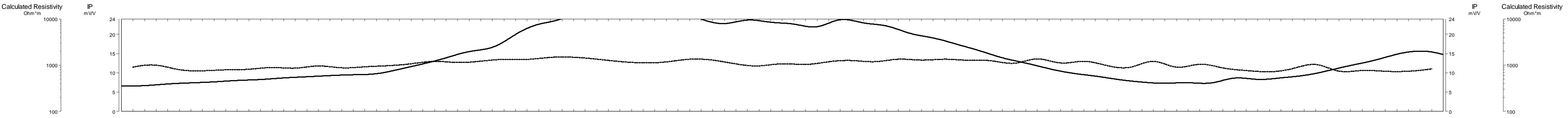

330+00 E

Dipole-Pole Array

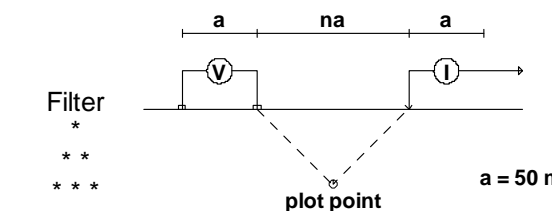

Instruments: Walcer 9.0kw Tx, Iris Pro Rx

Frequency: 0.125 Hz. Mdly 200ms 20*50ms Windows
Operators: M.M., P.C.

Logarithmic Contours
1, 1.5, 2, 3, 5, 7.5, 10,...

INTERPRETATION

Well defined, strong increase in polarization with or without marked decrease in resistivity.

Fairly well defined moderate increase in polarization.

Fairly well defined weak increase in polarization.

Resistivity feature.

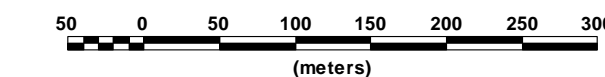

HEWETT

INDUCED POLARIZATION SURVEY
MAX K2 PROPERTY

Date: SEPTEMBER 2010

PETER E. WALCOTT & ASSOCIATES LIMITED

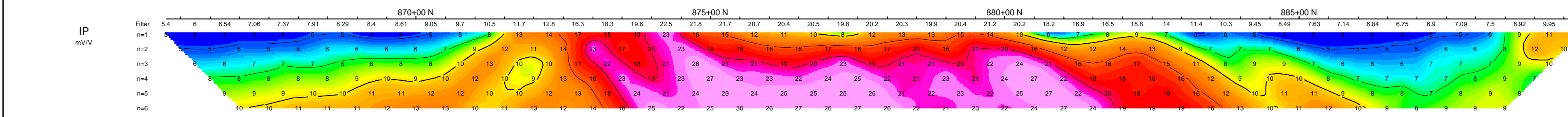
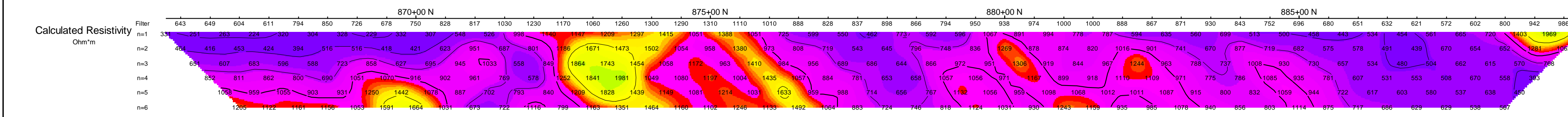
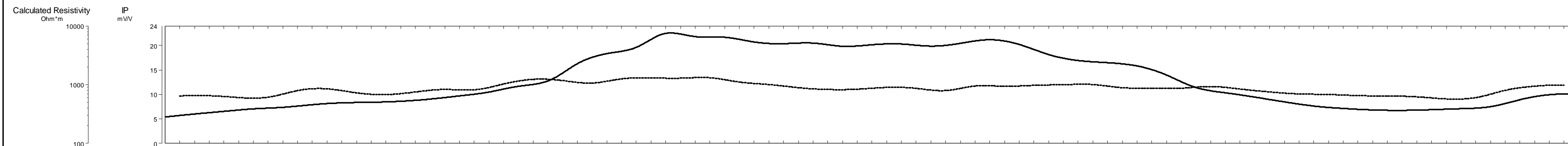

Line 32000

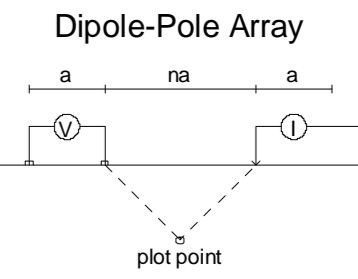

Modelled Resistivity (Ohm-m)

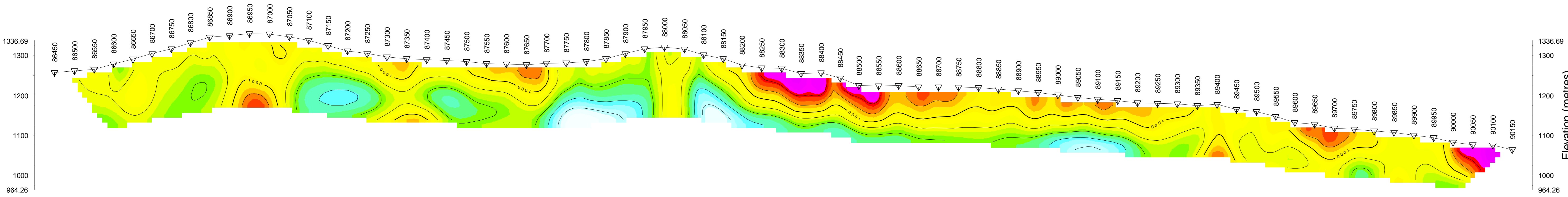

Modelled Chargeability (mV/V)

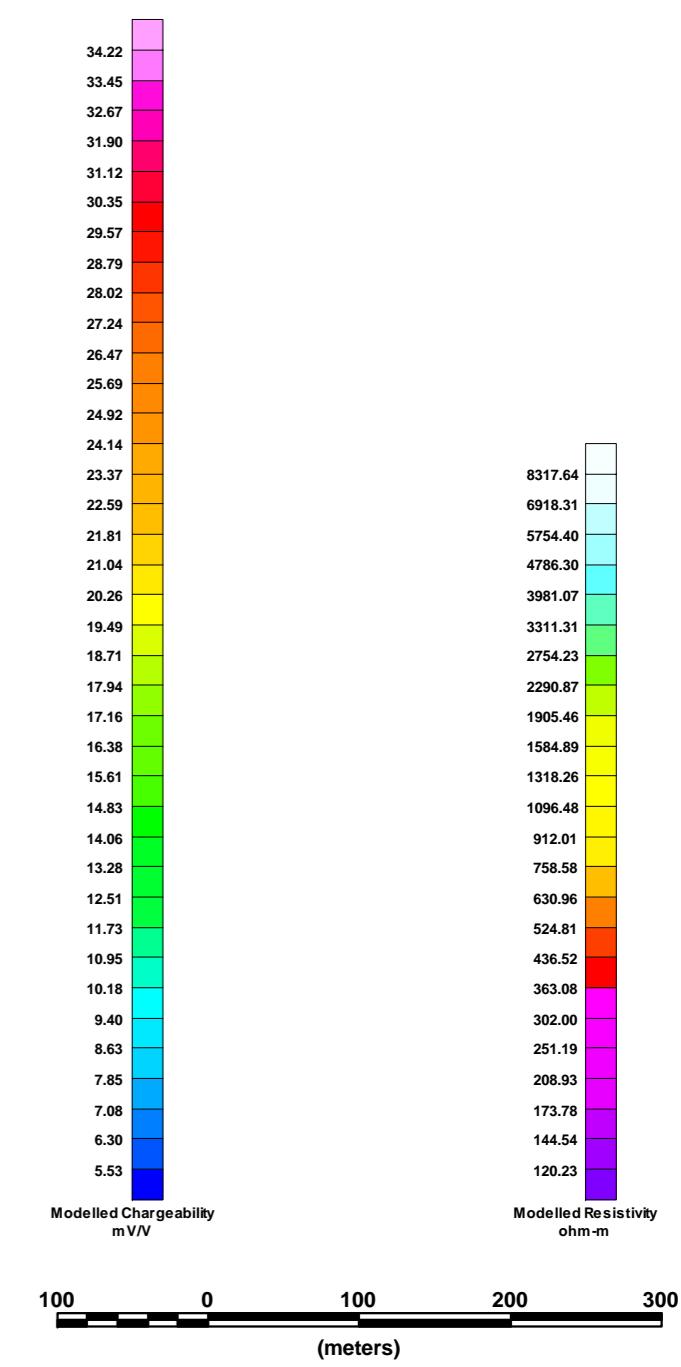
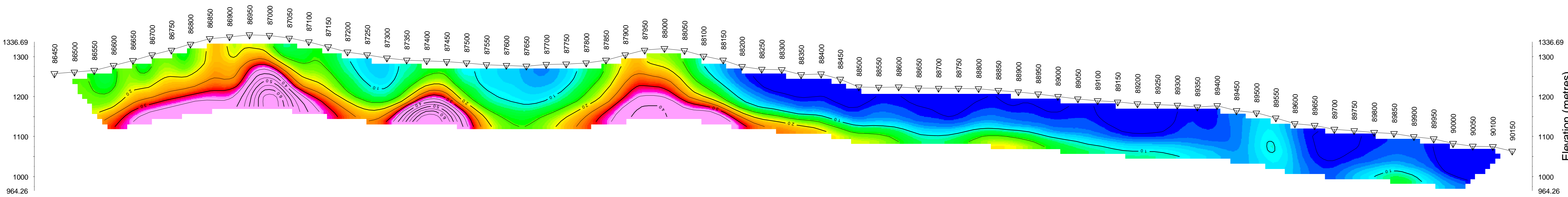

ANTHONY HEWETT
 INDUCED POLARIZATION SURVEY
 MAX K2, FT ST. JAMES
 OCTOBER 2010
 RES2DINV
 Inversion By: PETER E. WALCOTT & ASSOCIATES LIMITED

Line 32200

Dipole-Pole Array

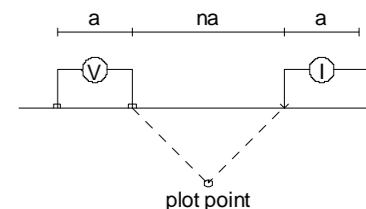

Modelled Resistivity (Ohm-m)

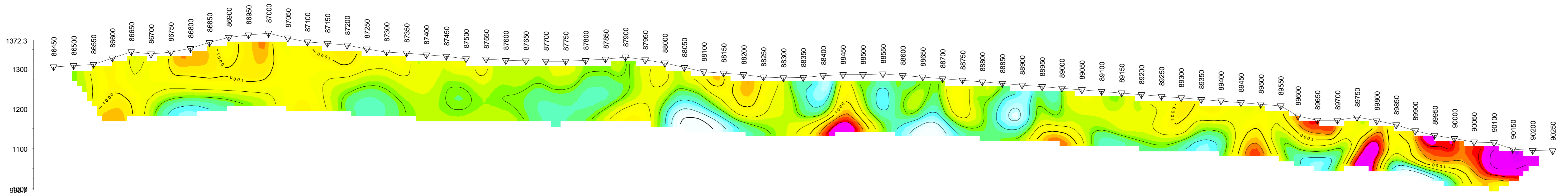

Modelled Chargeability (mV/V)

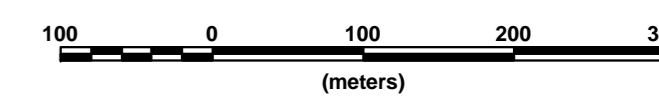
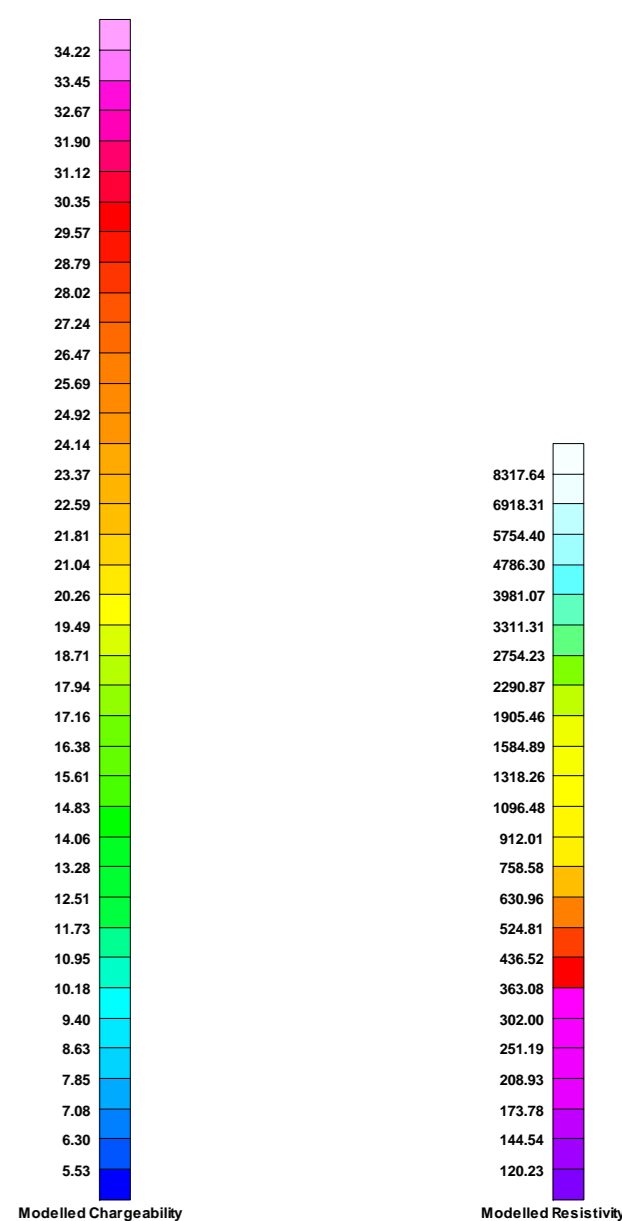
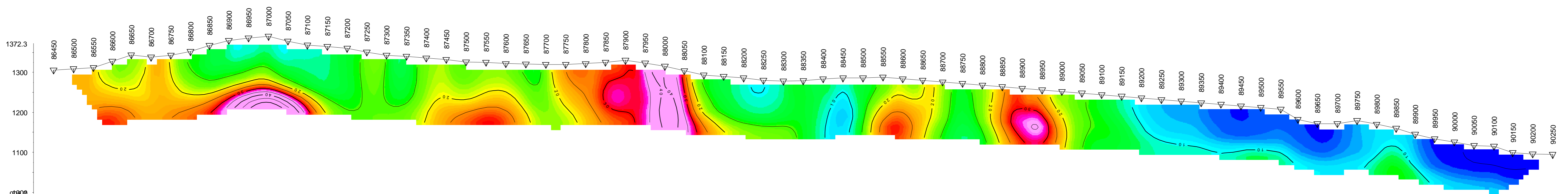

ANTHONY HEWETT
INDUCED POLARIZATION SURVEY
MAX K2, FT. ST. JAMES
OCTOBER 2010
RES2DINV
Inversion By: PETER E. WALCOTT & ASSOCIATES LIMITED

Line 32400

Dipole-Pole Array

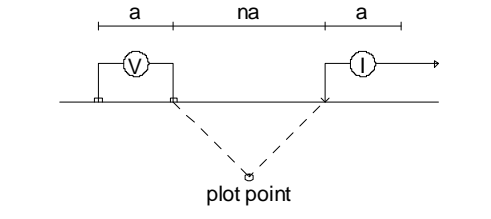

Modelled Resistivity (Ohm-m)

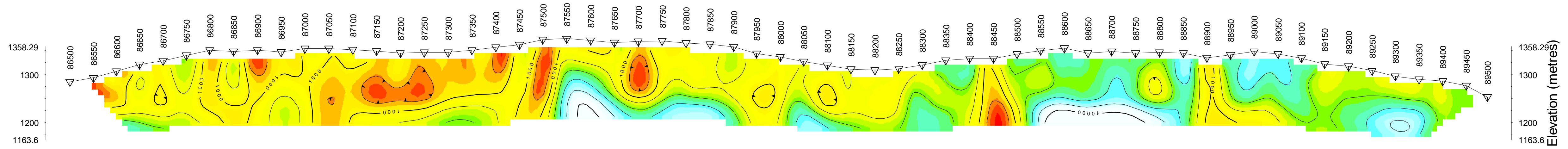

Modelled Chargeability (mV/V)

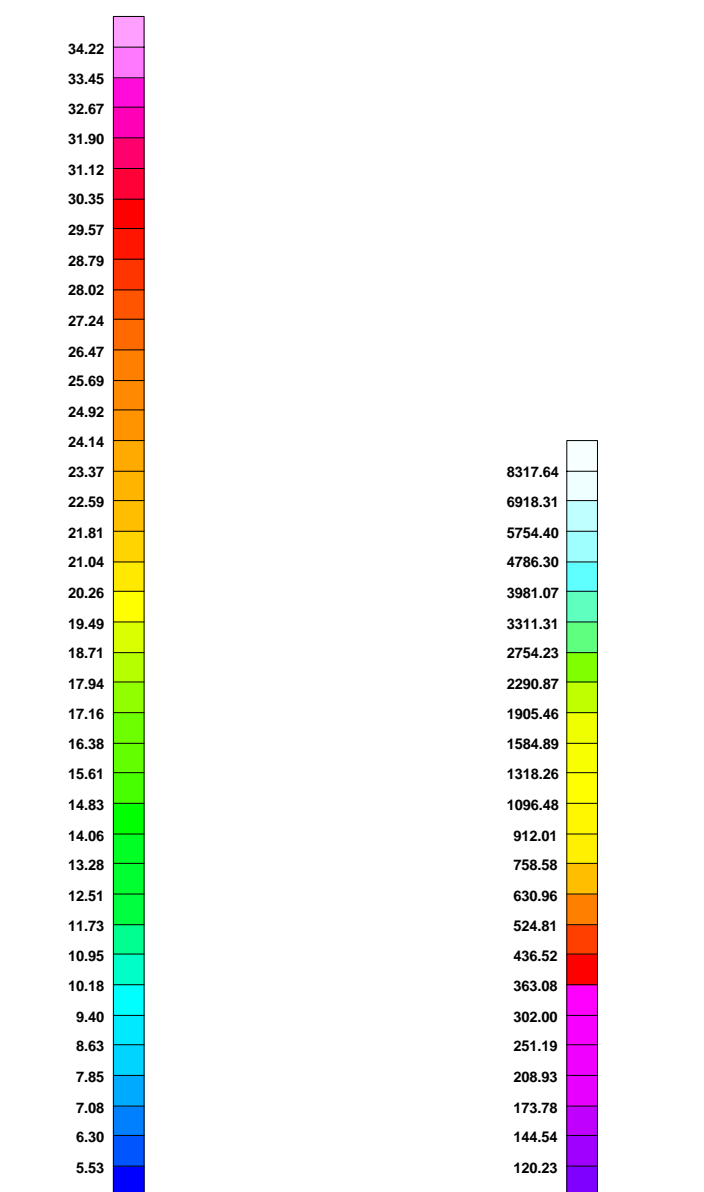
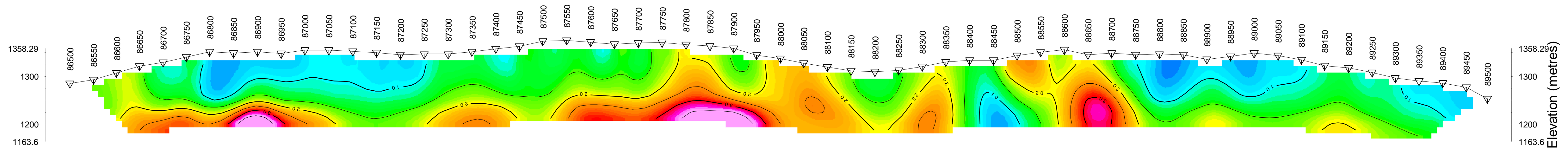

ANTHONY HEWETT
 INDUCED POLARIZATION SURVEY
 MAX K2, FT. ST. JAMES
 OCTOBER 2010
 RES2DINV
 Inversion By: PETER E. WALCOTT & ASSOCIATES LIMITED

Line 32600

Dipole-Pole Array

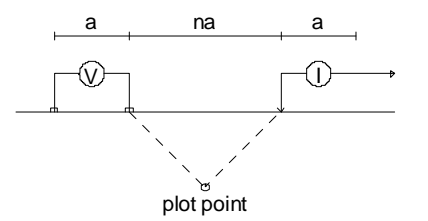

Modelled Resistivity (Ohm-m)

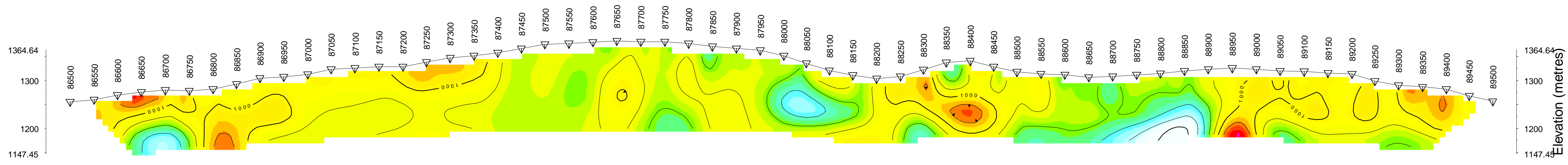

Modelled Chargeability (mV/V)

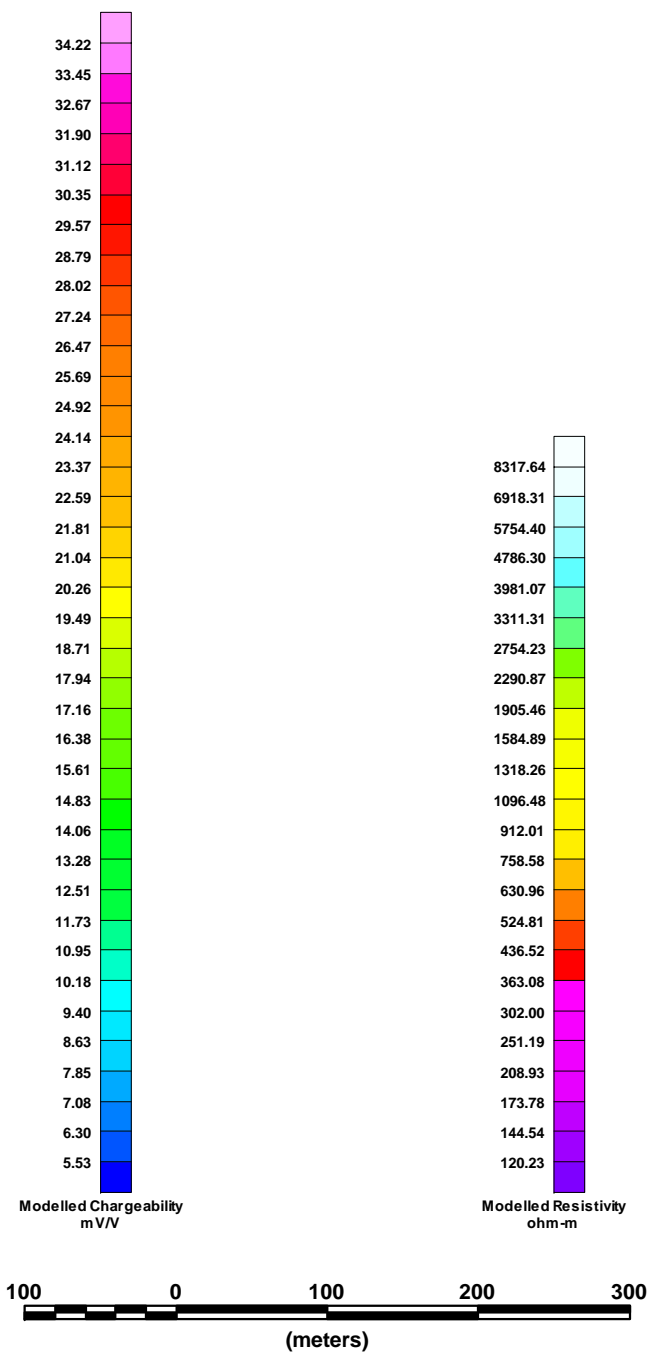
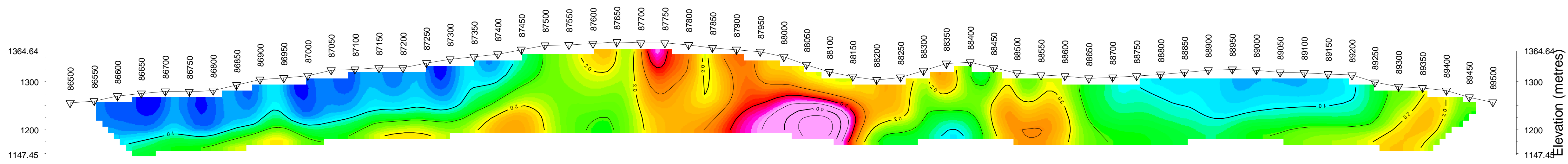

ANTHONY HEWETT
 INDUCED POLARIZATION SURVEY
 MAX K2, FT. ST. JAMES
 OCTOBER 2010
 RES2DINV
 Inversion By: PETER E. WALCOTT & ASSOCIATES LIMITED

Line 32800

Dipole-Pole Array

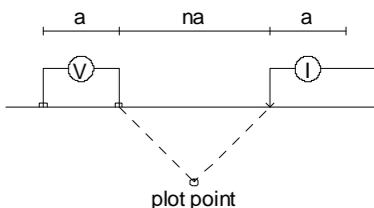

Modelled Resistivity (Ohm-m)

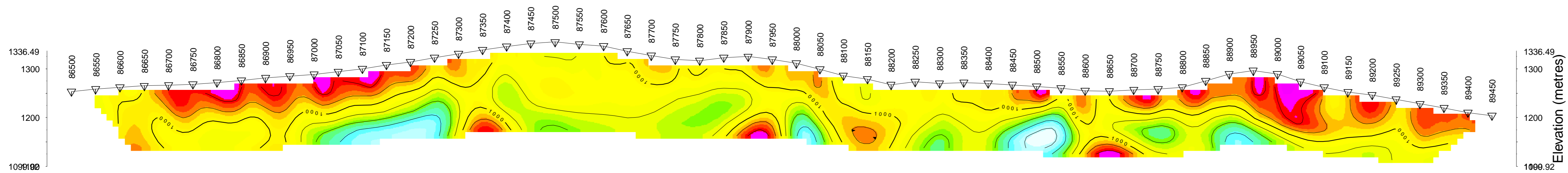

Modelled Chargeability (mV/V)

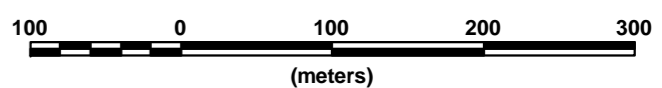
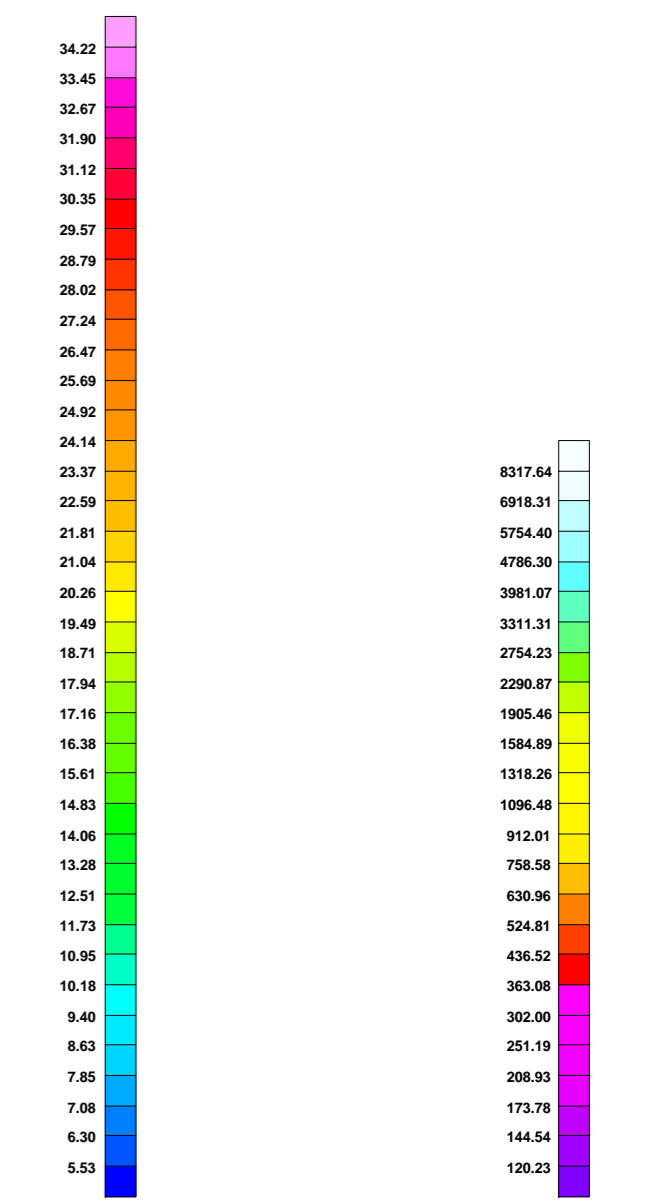
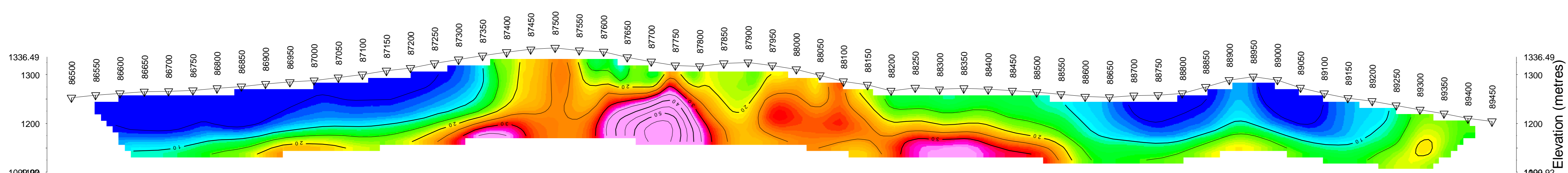

ANTHONY HEWETT
 INDUCED POLARIZATION SURVEY
 MAX K2, FT. ST. JAMES
 OCTOBER 2010
 RES2DINV
 Inversion By: PETER E. WALCOTT & ASSOCIATES LIMITED

Line 33000

Dipole-Dipole Array

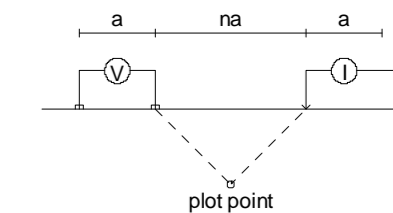

Modelled Resistivity (Ohm-m)

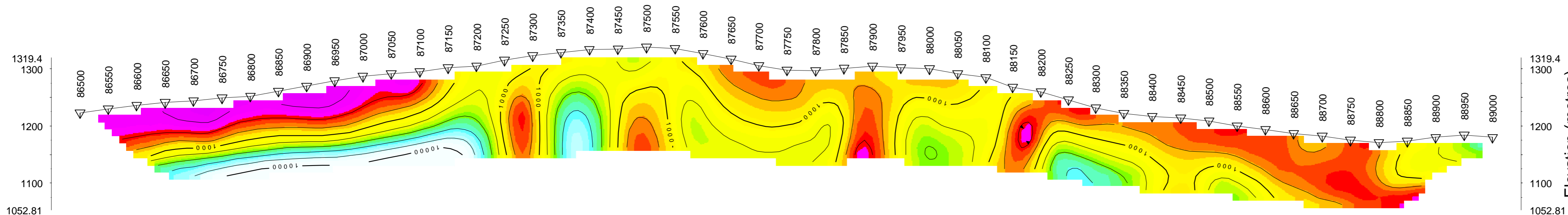

Modelled Chargeability (mV/V)

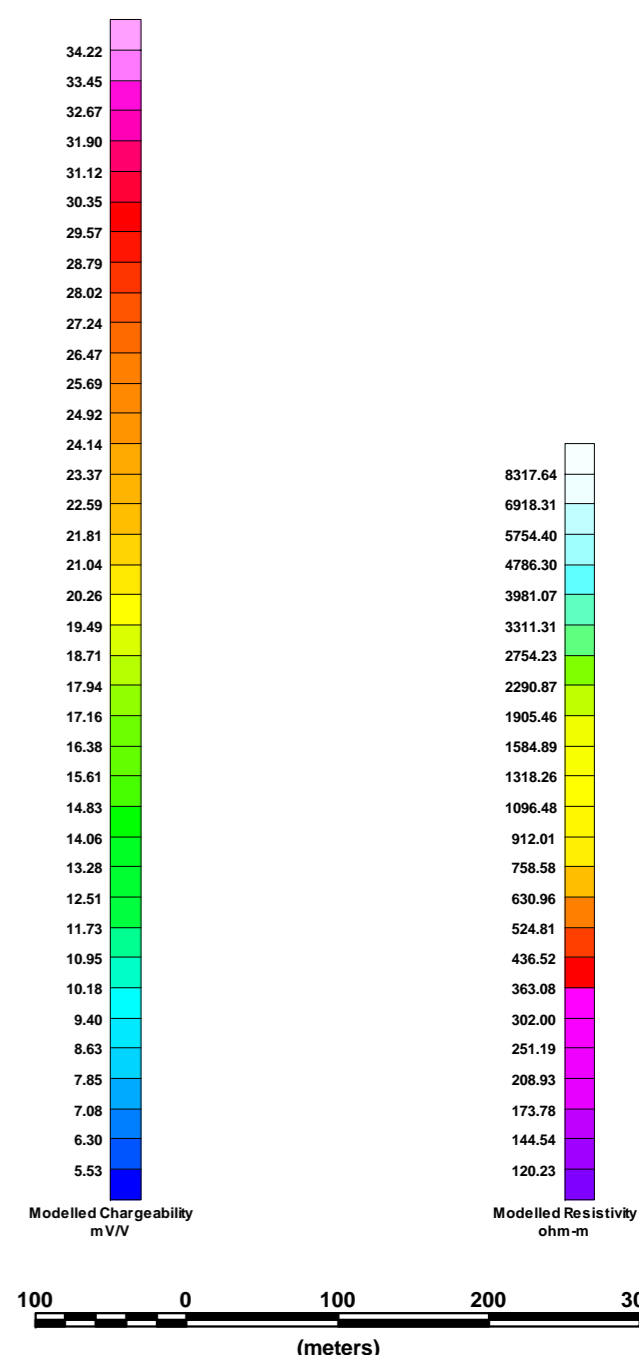
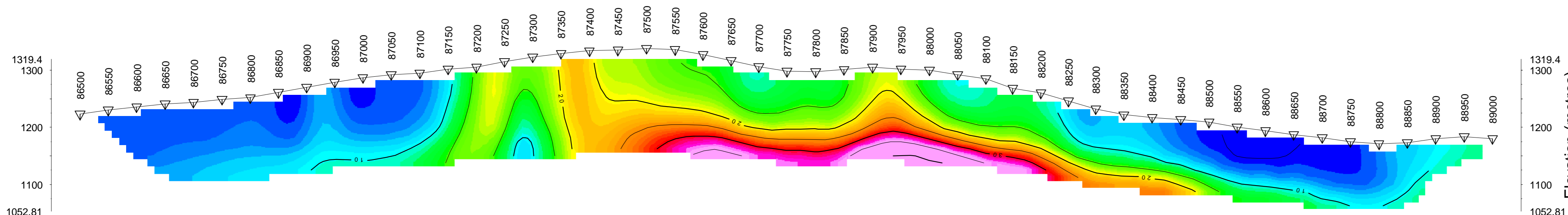

ANTHONY HEWETT
 INDUCED POLARIZATION SURVEY
 MAX K2, FT. ST. JAMES
 OCTOBER 2010
 RES2DINV
 Inversion By: PETER E. WALCOTT & ASSOCIATES LIMITED

APPARENT CHARGEABILITY (mV/V)

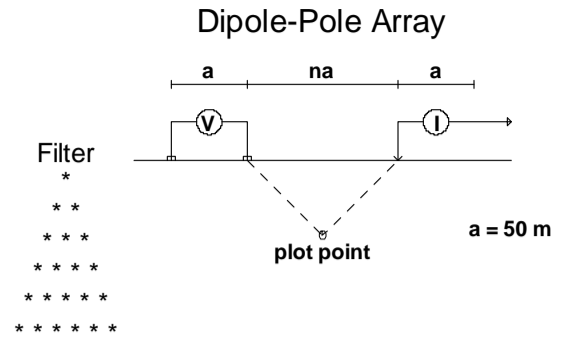
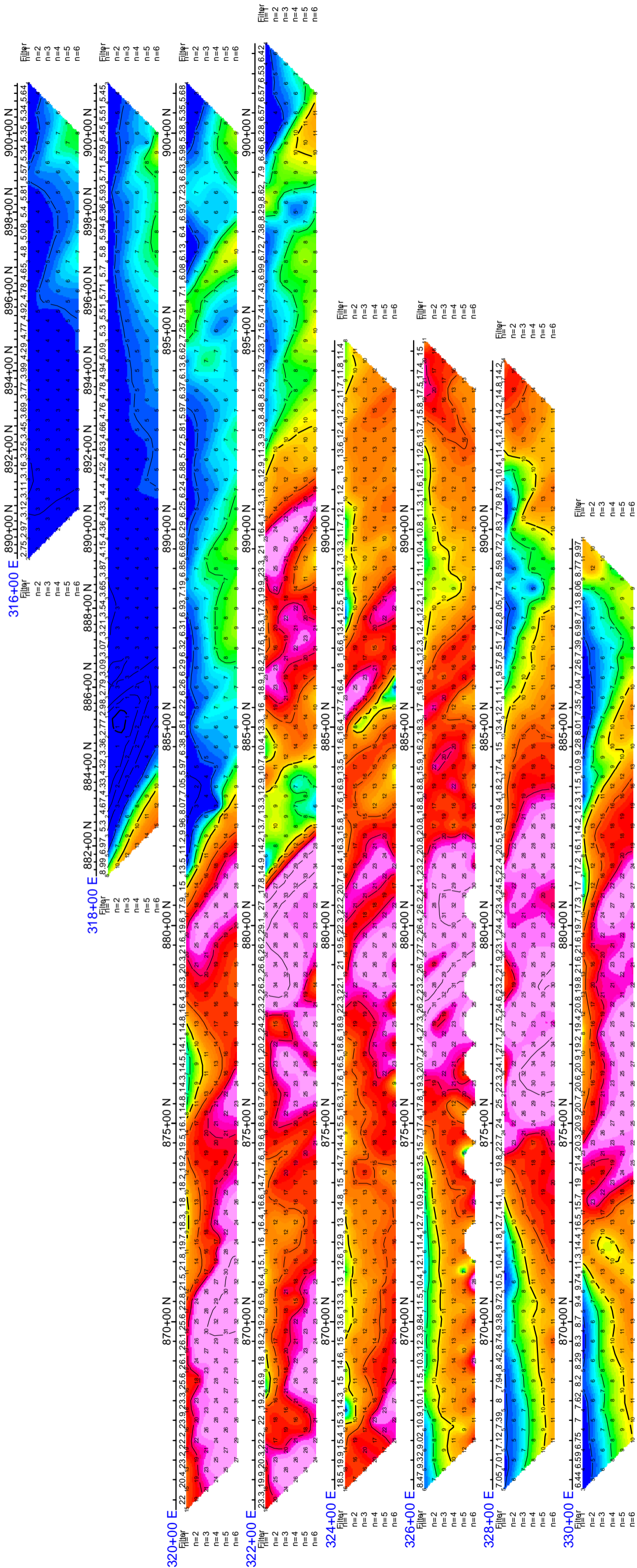

Instruments: Walcer 9.0kw Tx, Iris Pro Rx
 Frequency: 0.125 Hz. Mdlly 200ms 20*50ms Windows
 Operators: M.M., P.C.

Logarithmic
 Contours: 1.5, 2, 3, 5, 7.5, 10, ...

INTERPRETATION

- Well defined, strong increase in polarization, with or without marked decrease in resistivity.
- Fairly well defined moderate increase in polarization.
- Fairly well defined weak increase in polarization.
- Resistivity feature.

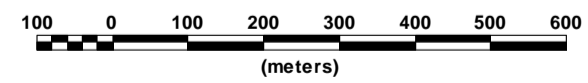

APPARENT RESISTIVITY (ohm-m)

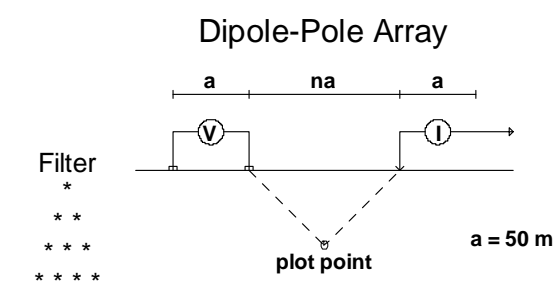
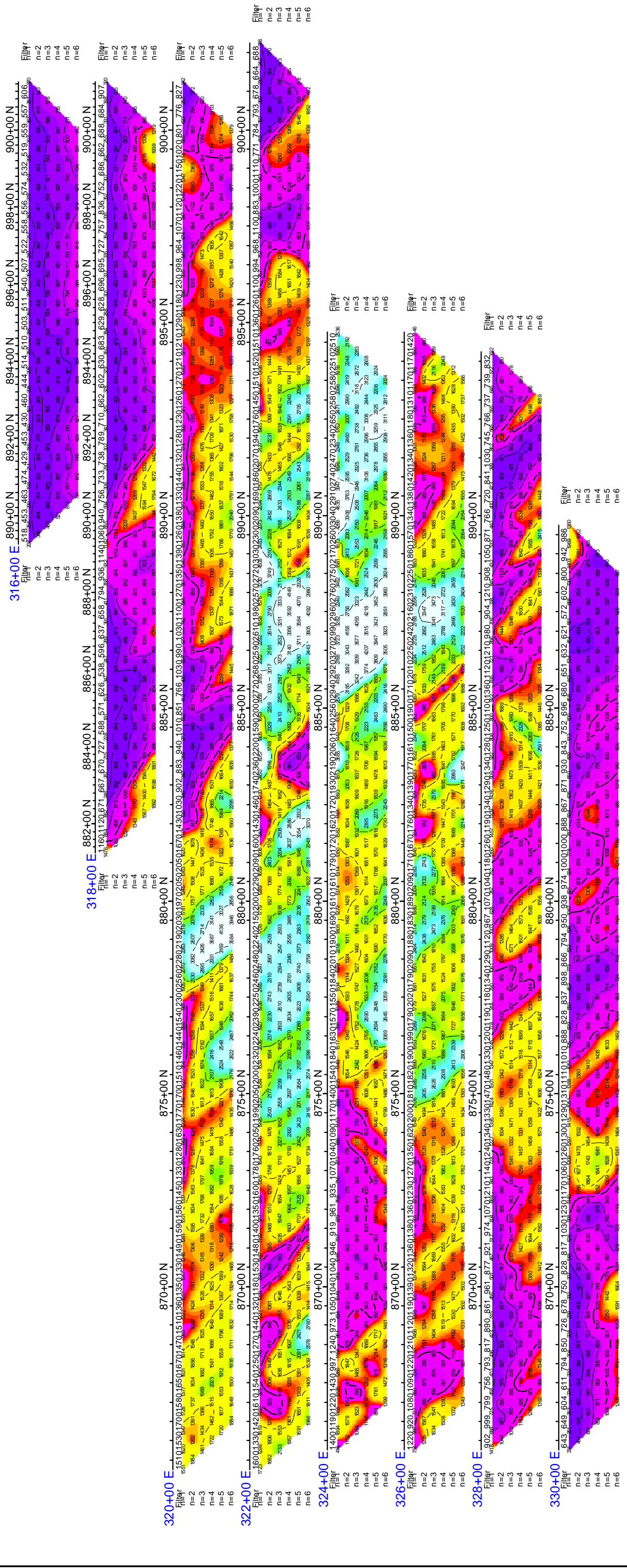

Instruments: Walcer 9.0kw Tx, Iris Pro Rx
 Frequency: 0.125 Hz. Mdly 20*50ms Windows
 Operators: M.M., P.C.

Logarithmic
 Contours: 1.5, 2, 3, 5, 7.5, 10,...

- ### INTERPRETATION
- Well defined, strong increase in polarization with or without marked decrease in resistivity.
 - Fairly well defined moderate increase in polarization.
 - Fairly well defined weak increase in polarization.
 - Resistivity feature.
- 100 0 100 200 300 400 500 600
 (meters)

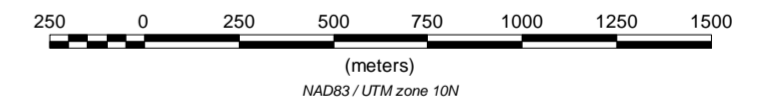
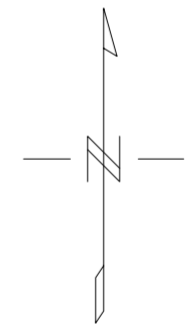
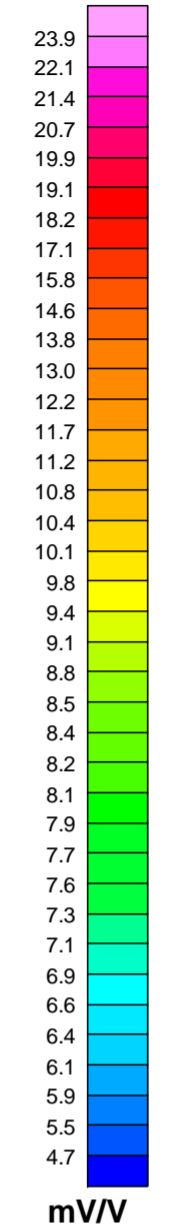
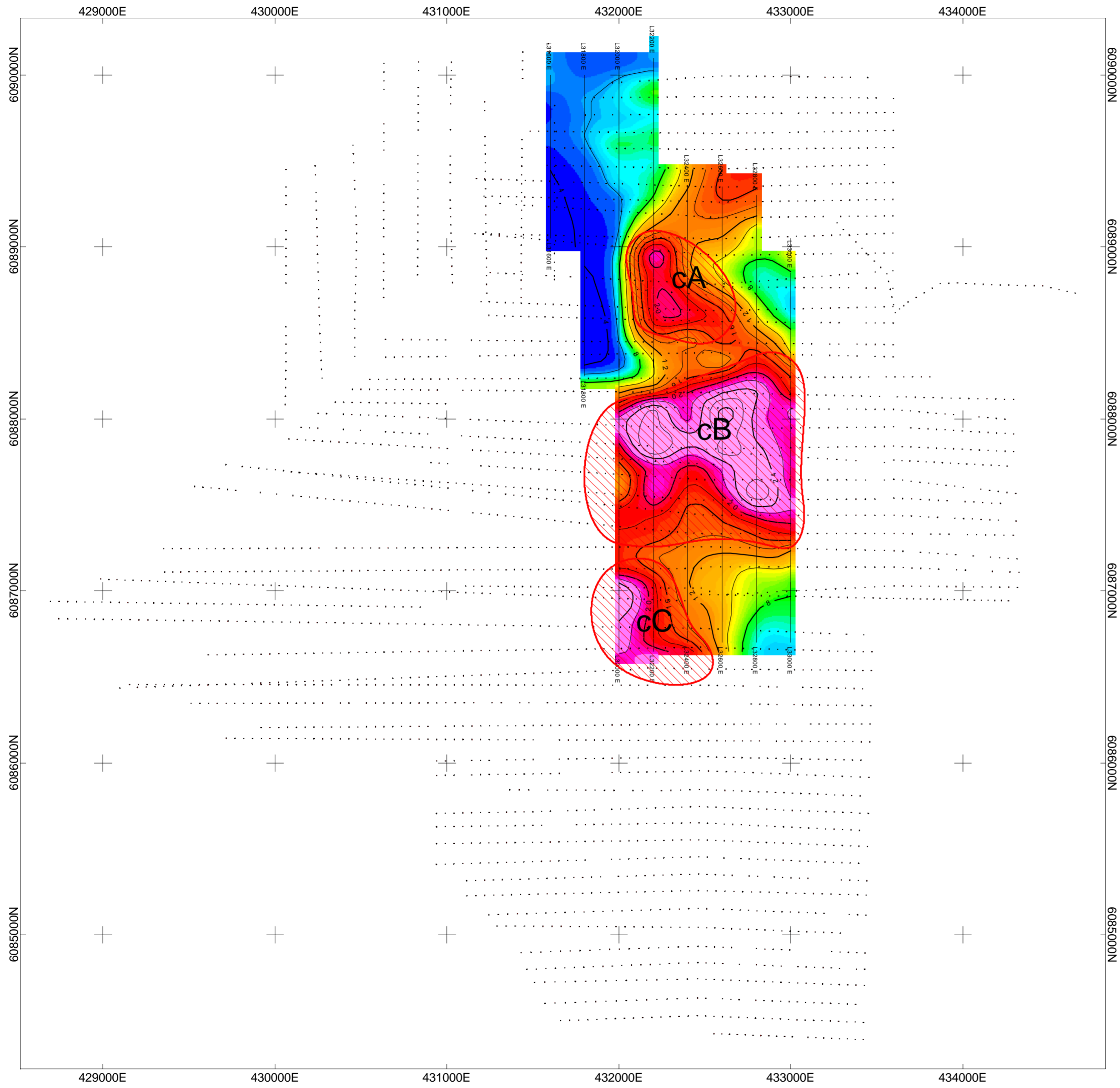

ANTHONY HEWETT
INDUCED POLARIZATION SURVEY
CONTOURS OF APPARENT CHARGEABILITY (mV/V) N=3
 K2-MAX PROJECT
 FT. ST. JAMES AREA, BRITISH COLUMBIA
 FEBRUARY 2010
PETER E. WALCOTT & ASSOCIATES LIMITED

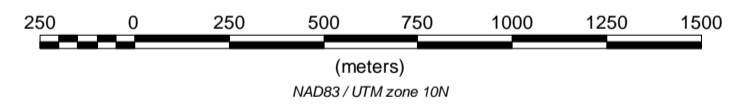
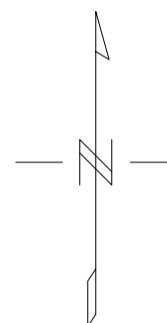
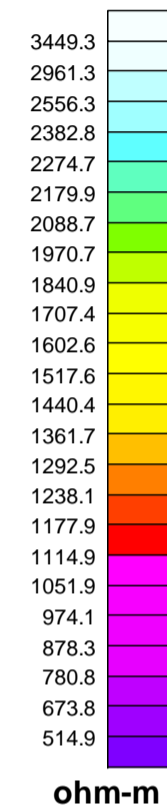
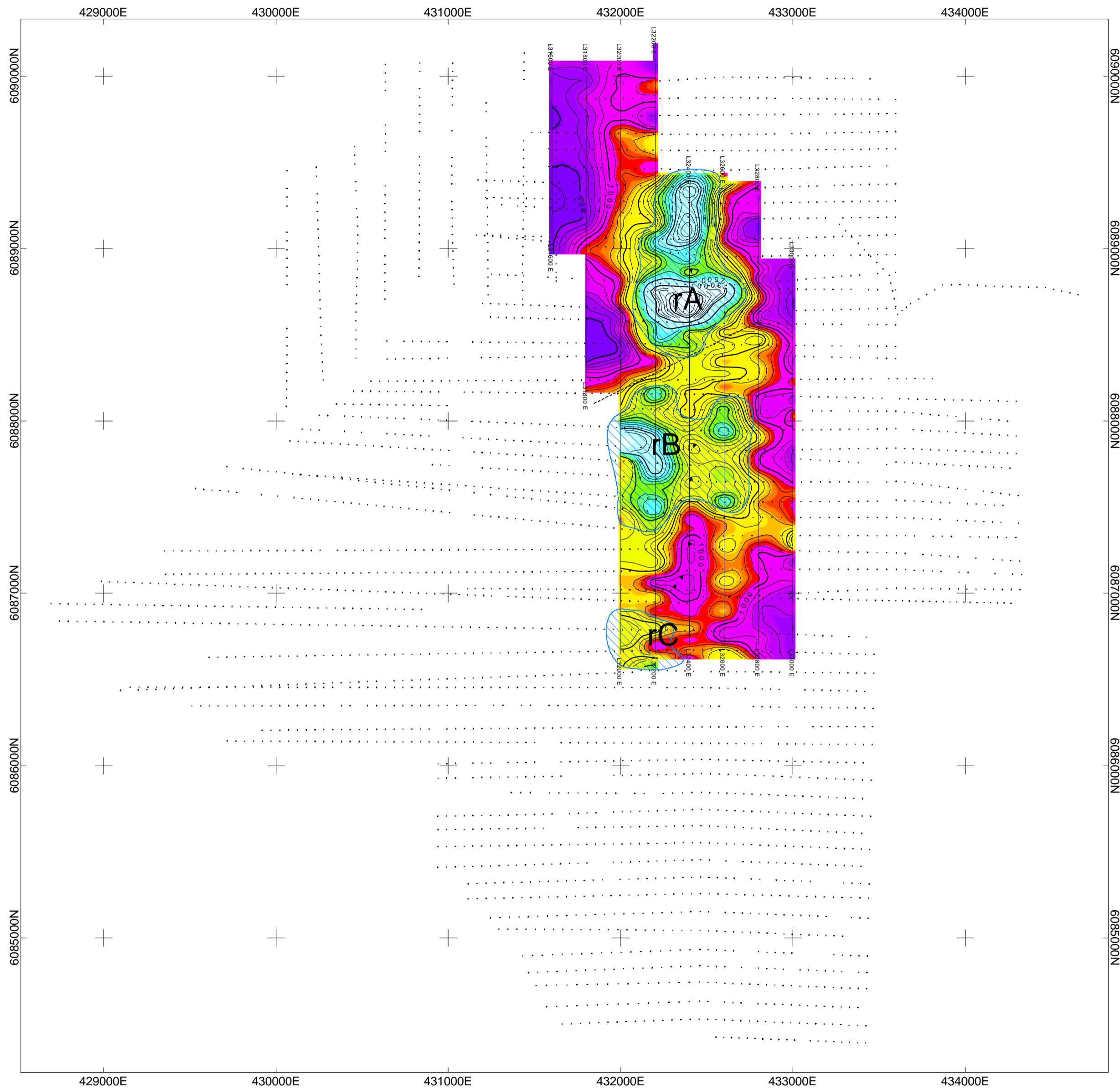

ANTHONY HEWETT
INDUCED POLARIZATION SURVEY CONTOURS OF APPARENT RESISTIVITY (ohm-m) N=3
K2-MAX PROJECT FT. ST. JAMES AREA, BRITISH COLUMBIA FEBRUARY 2010
PETER E. WALCOTT & ASSOCIATES LIMITED

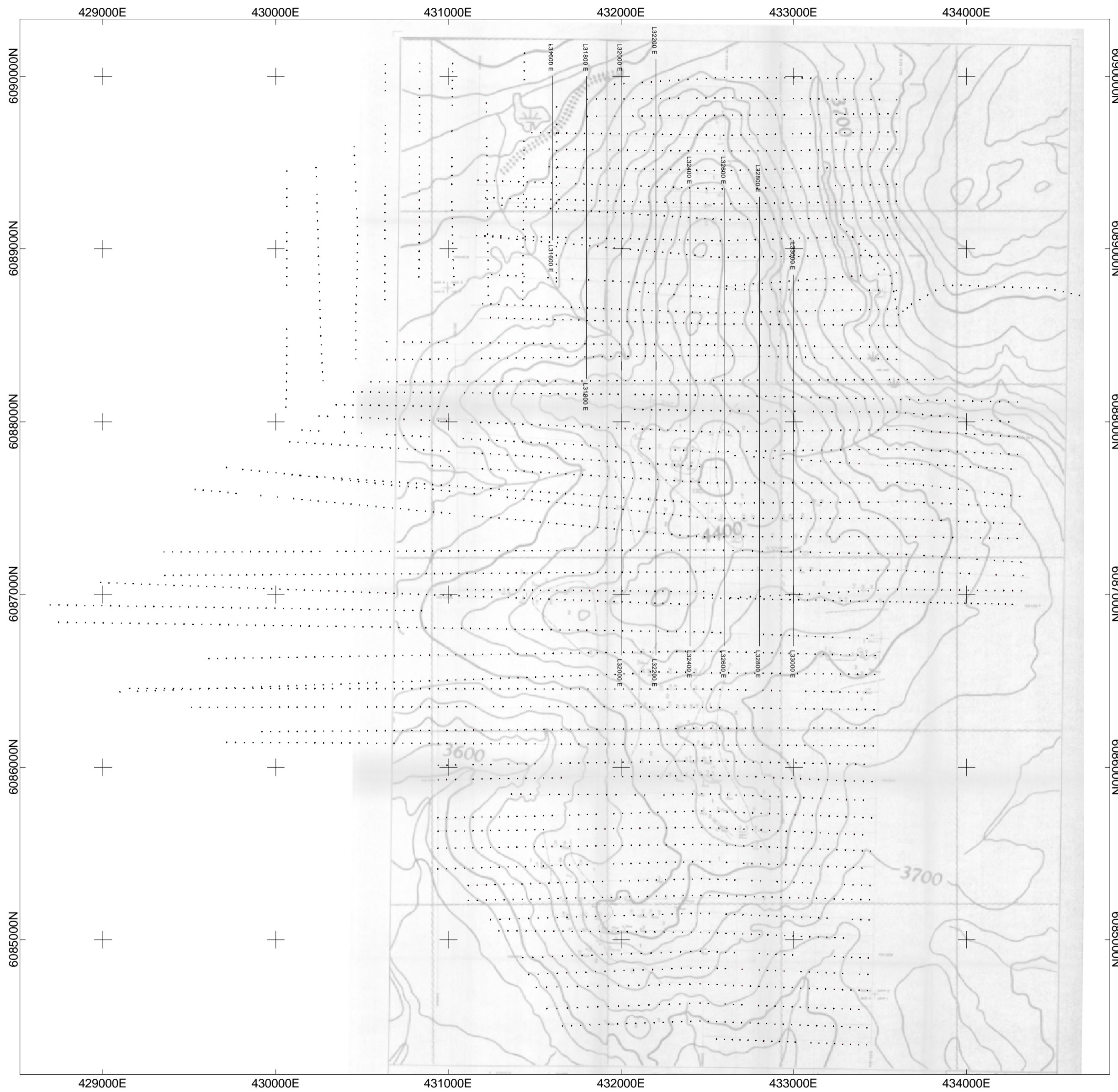

6090000N
6089000N
6088000N
6087000N
6086000N
6085000N

429000E 430000E 431000E 432000E 433000E 434000E

429000E 430000E 431000E 432000E 433000E 434000E

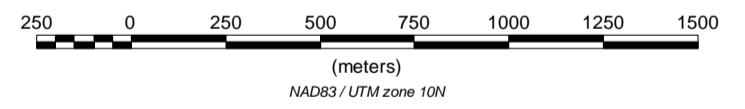
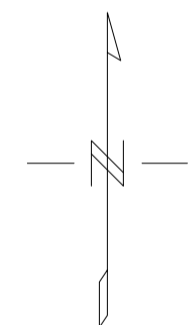

ANTHONY HEWETT
GEOLOGY (W. Donaldson, 1991 - ARIS 21873) with IP LINE LOCATIONS
K2-MAX PROJECT FT. ST. JAMES AREA, BRITISH COLUMBIA FEBRUARY 2010
PETER E. WALCOTT & ASSOCIATES LIMITED

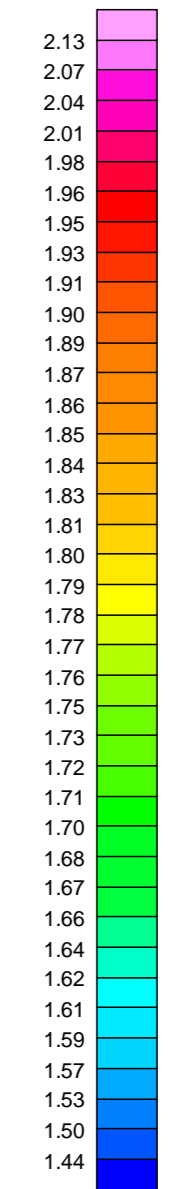
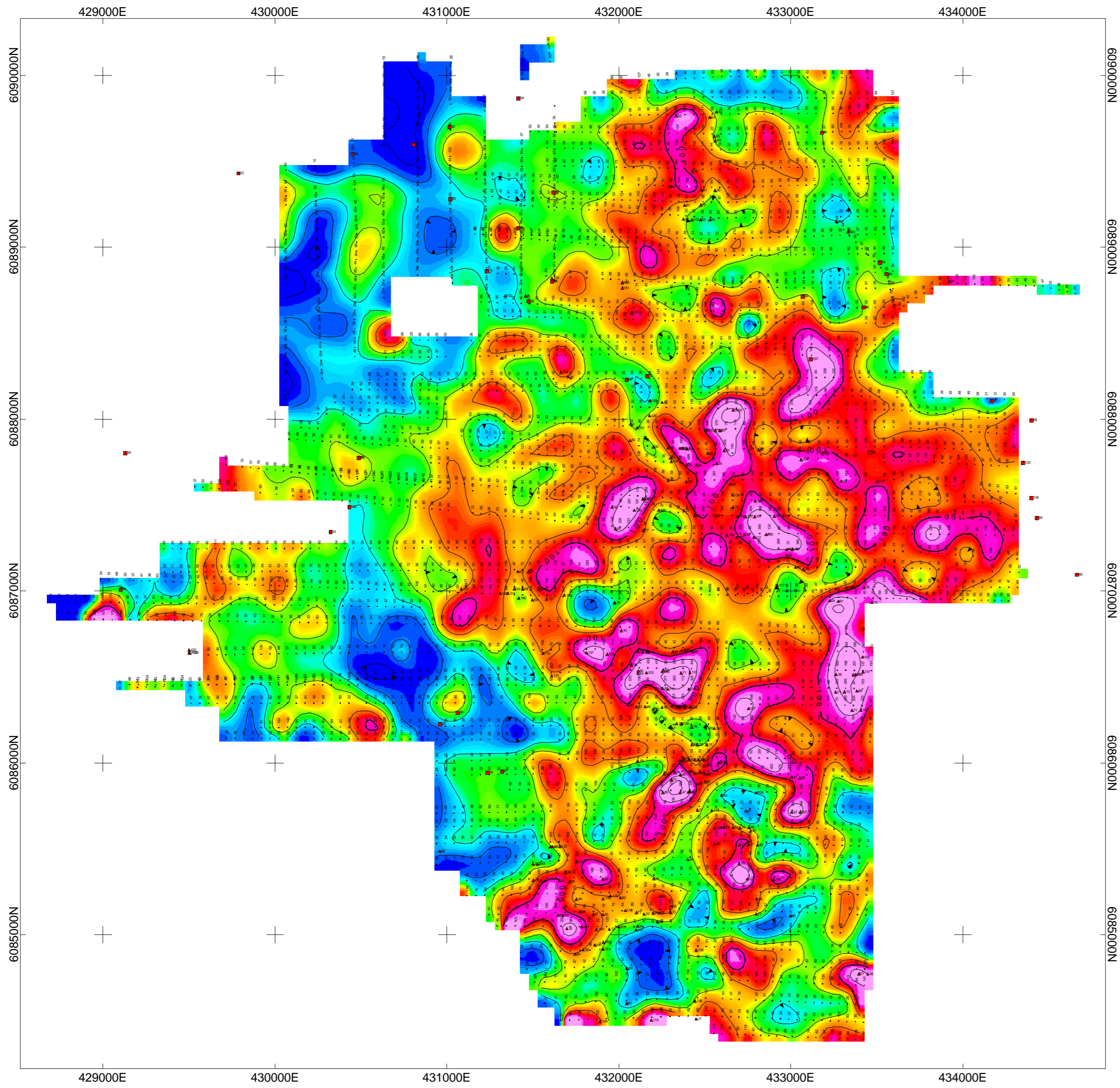

log (ppm)

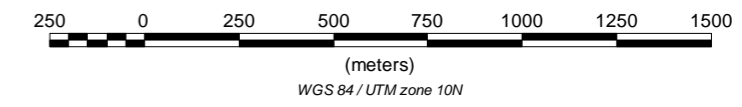
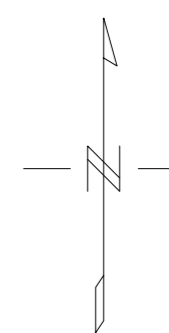

ANTHONY HEWETT
SOIL GEOCHEMISTRY CONTOURS OF COPPER (ppm)
K2-MAX PROJECT FT. ST. JAMES AREA, BRITISH COLUMBIA FEBRUARY 2010
PETER E. WALCOTT & ASSOCIATES LIMITED

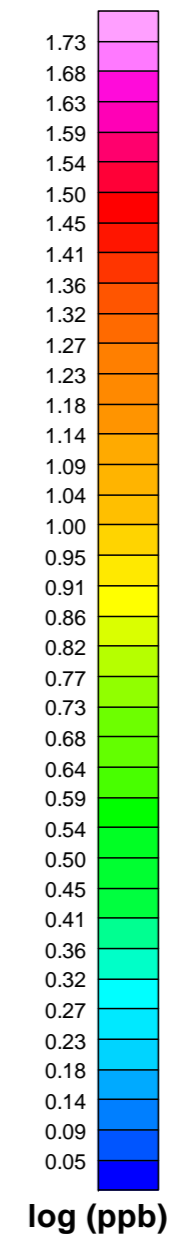
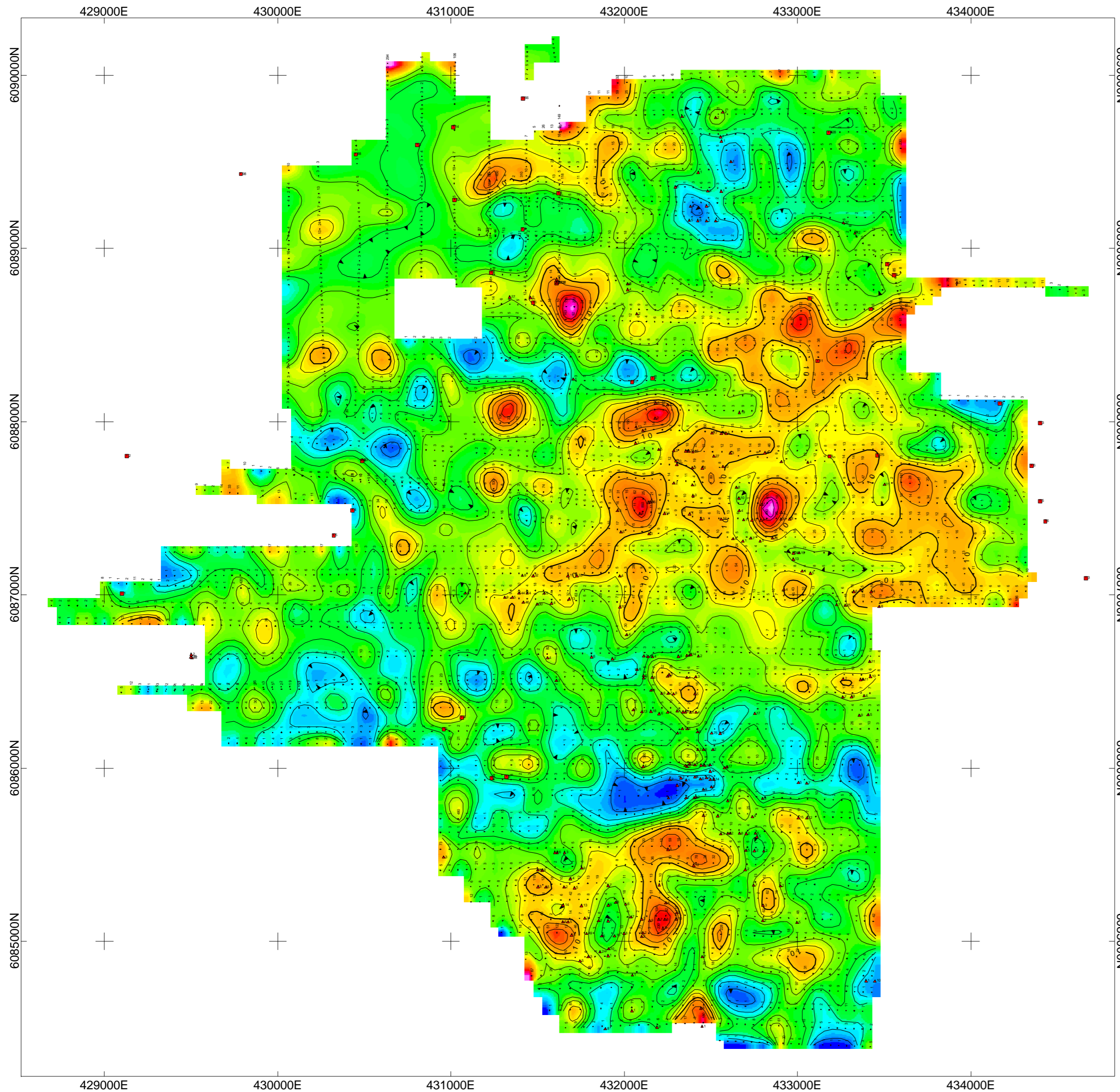

log (ppb)

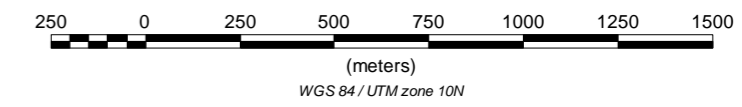
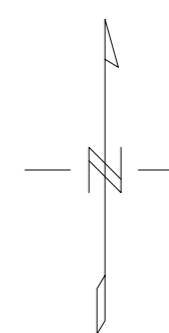

ANTHONY HEWETT
SOIL GEOCHEMISTRY CONTOURS OF GOLD (ppb)
K2-MAX PROJECT FT. ST. JAMES AREA, BRITISH COLUMBIA FEBRUARY 2010
PETER E. WALCOTT & ASSOCIATES LIMITED

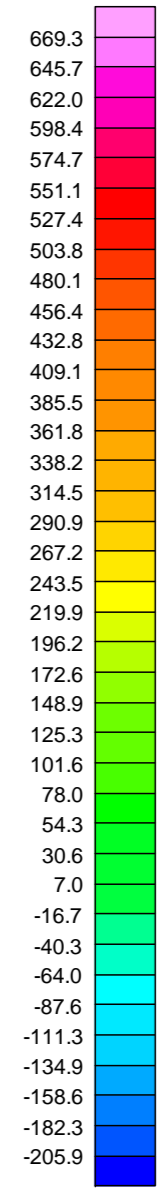
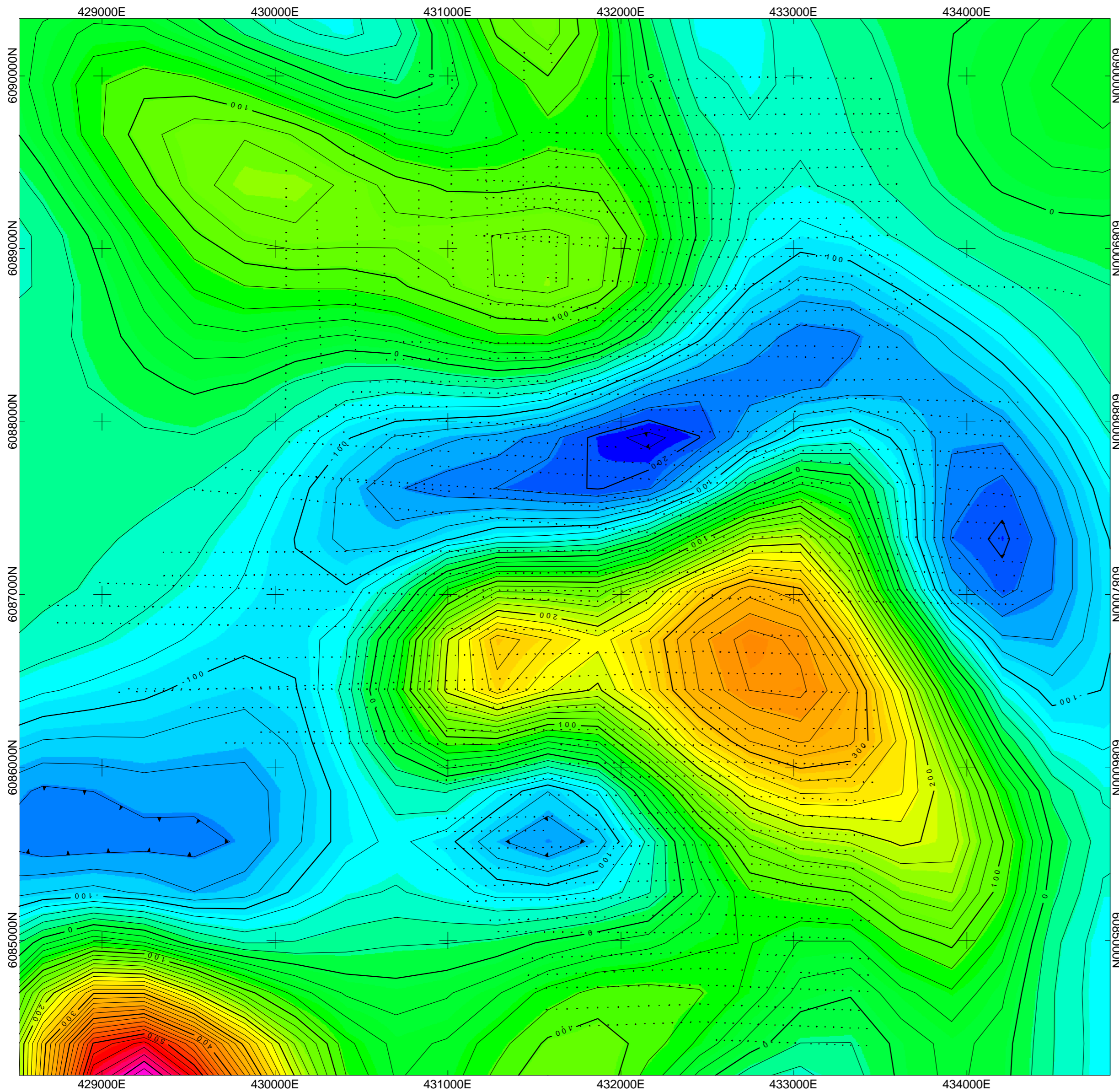

nT

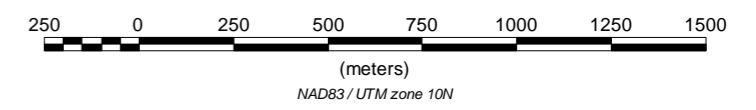
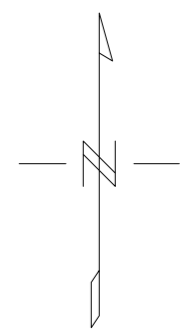

ANTHONY HEWETT
AIRBORNE MAGNETIC SURVEY CONTOURS OF RESIDUAL TMI (nT)
K2-MAX PROJECT FT. ST. JAMES AREA, BRITISH COLUMBIA FEBRUARY 2010
PETER E. WALCOTT & ASSOCIATES LIMITED

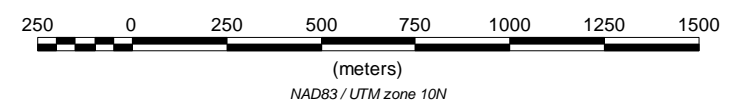
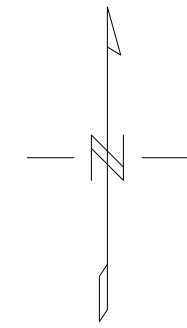
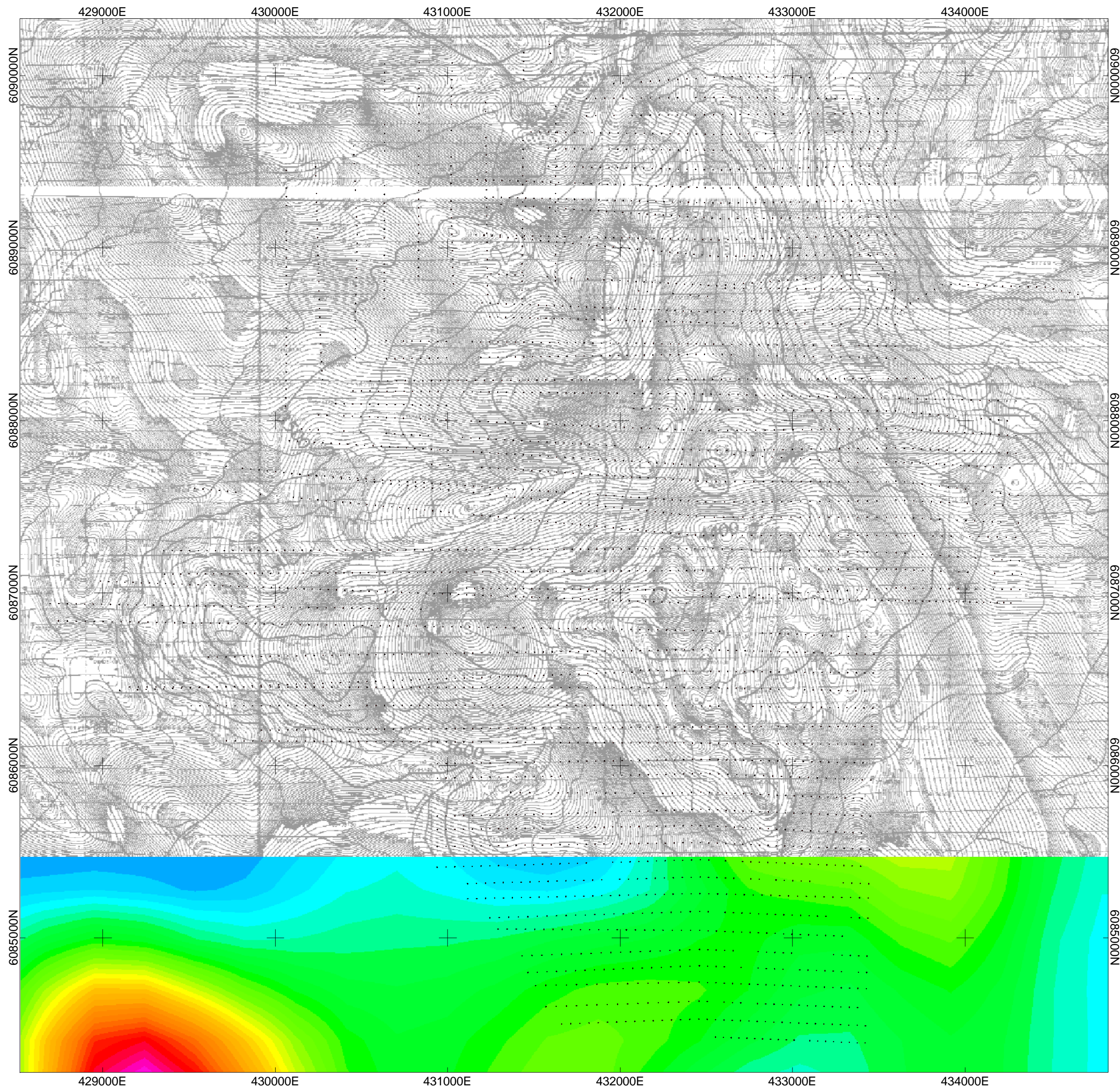

ANTHONY HEWETT
AIRBORNE MAGNETIC SURVEY CONTOURS OF RESIDUAL TMI (nT) with Historic Mag
K2-MAX PROJECT FT. ST. JAMES AREA, BRITISH COLUMBIA FEBRUARY 2010
PETER E. WALCOTT & ASSOCIATES LIMITED

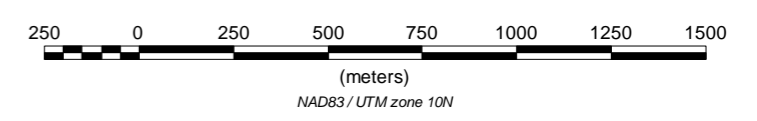
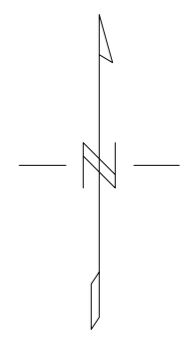
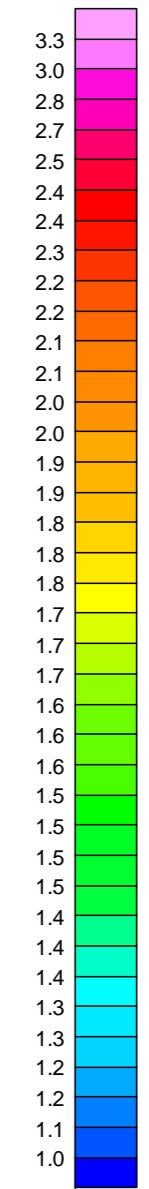
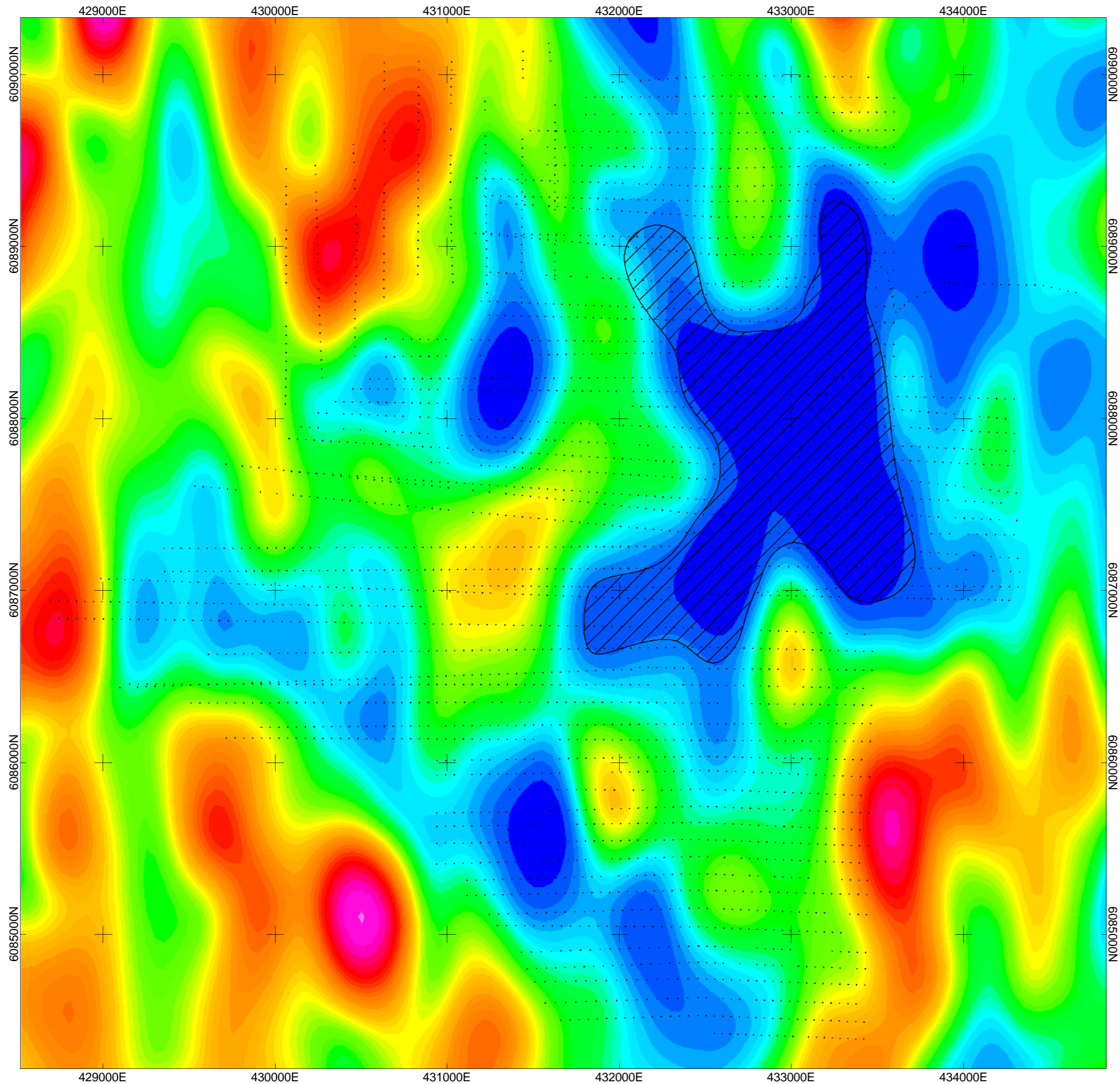

ANTHONY HEWETT
AIRBORNE RADIOMETRIC SURVEY CONTOURS OF eTH/K
K2-MAX PROJECT FT. ST. JAMES AREA, BRITISH COLUMBIA FEBRUARY 2010
PETER E. WALCOTT & ASSOCIATES LIMITED

AIRBORNE GEOPHYSICAL INTERPRETATION REPORT

ON THE

MAX-K2 PROPERTY

OMINECA MINING DIVISION

NTS 093K/16E OR 093K.100

54⁰ 56' North Latitude, 124⁰ 02' West Longitude

For

**Anthony James Hewett
Vancouver B.C.**

By

**D. E. Blann, P.Eng.
Standard Metals Exploration Ltd
August 26, 2010**

Table of Contents

1.	Location and Access	4
2.	Claim Status	4
3.	History.....	5
4.	Regional Geology.....	6
5.	Property Geology.....	8
6.	2010 Work.....	10
7.	Discussion	10
8.	Conclusions.....	11
9.	Recommendations and Budget	13
10.	Statement of Costs.....	13
11.	References	14
	Statement of Qualifications.....	16

Appendix 1 Figures

- 1) B.C. Property Location
- 2) Mineral Tenure Location
- 3) Regional Geology
- 4) Property Geology
- 5) Soil Geochemical Results (Copper, PPM)
- 6) Soil Geochemical Results (Gold, PPB)

Appendix 2

Shives, Robert, 2010, Interpretation Report of 1995 Regional Fixed Win Airborne Gamma Ray Spectrometric/Magnetic Data over the MAX PROPERTY Omineca Mining Division, British Columbia Canada NTS 93K/16E.

Summary

The MAX property is located approximately 57 kilometres northeast of Ft St James, British Columbia. The Mount Milligan copper-gold deposit (Minfile 093N194) owned by Terrane Metals Inc., is located approximately 22 kilometres to the north of the Max property, and the Tas property (Minfile 093K080) is located approximately 14 kilometres to the west.

The Mount Milligan copper-gold deposit, containing mineable reserves of 6.0 million ounces of gold and 2.0 billion pounds of copper is currently at the construction stage and is located approximately 22 kilometres to the north. The MAX property is owned 100% by Anthony James Hewett.

The MAX property is 41 square kilometres in area and was explored largely between 1988 and 1991 by Rio Algom Explorations Inc., and again briefly in 2007 by Standard Metals Exploration Ltd. The exploration consisted of stream sediment, soil and rock geochemical, geological, limited ground geophysical, and an airborne VLF-EM and magnetic geophysical survey. Together, this work outlined favorable lithology and an alteration and pyrite-pyrrhotite bearing sulphide system approximately 25 square kilometres in dimension, one of the largest in the area. Important, multi-phase high-magnetite bearing diorite and monzonite intrusions occur that are similar to those within and adjacent the Mount Milligan deposits. Exploration results from Rio Algom include a coincident copper and gold in soil anomaly between 1.0 to 2.5 kilometres in length and 0.5 to 1.5 kilometres in width with test pits locally containing up to 3.3 g/t gold. In 2007, results include up to 2725.8 ppb (2.7 g/t) gold in a pan concentrate, and 475.1 ppb (0.47g/t) gold with 98.1 ppm copper in a silt sample. Anomalous values of up to 1.8 ppm silver and 20 ppb rhenium were also obtained in silt samples and a reconnaissance soil line in the northeast portion of the Max property returned up to 193 ppm copper, and 106.1 ppb gold, and rock samples returned up to 7156 ppm (0.71%) copper, 40840 ppb (40.8 g/t) silver from narrow quartz carbonate chalcopyrite filled shear zones.

During 2010, a detailed review and analyses of the 1995 Airborne Geophysical survey was performed by Dr. Rob Shives of GamX Inc., whom in part conducted and supervised the original airborne survey and is recognized as an expert in the field of radiometric, geophysical/geochemical surveys. In order to facilitate this interpretation, historical geochemical data was manually entered into spreadsheets, and using Autocad and GIS software, historical data was converted into NAD83 UTM coordinates.

It is concluded the MAX property holds good potential for alkaline style bulk tonnage copper-gold mineralization and several priority targets for follow exploration work is recommended.

1. Location and Access

The Max property is located approximately 57 kilometres north of Ft. St. James, British Columbia (Figure 1). The center of the claims is approximately 0432000E and 6088000N based on the NAD 83 UTM system. The Mount Milligan copper-gold deposit (Minfile 093N194) owned by Terrane Metals Inc., is located approximately 22 kilometres to the north of the Max property, and the Tas property (Minfile 093K080) is located approximately 14 kilometres to the west.

Access is via the Germansen landing gravel logging road that heads north from town. A generally recent Rainbow road forestry access road turns east and branches to the north and east, accessing new cut blocks and recent fires in the mid-late 1990's. New roads have been constructed since the last recorded exploration work on the property that access higher elevations in the western, central, northern portions of the property.

The physiography of the property includes being part of the northern boundary of the Fraser river basin, of generally low and wide valleys. North of Ft. St. James, the terrain rises in elevation and low to moderately angled, till covered and locally rocky hills occur in the area of the Max property. The property occurs between 850 to 1370 metres elevation, with minor bedrock occurring near steep angled ridges. Trees include fir, spruce and pine, while groundcover is comprised of thistle, devils club, and other sub-alpine plants occur. Extensive areas of beetle killed trees occur where not already logged.

2. Claim Status

The Max property is composed of eleven (10) claims totaling approximately 4,145 hectares that are registered in the name of Anthony James Hewett of Vancouver, B.C. (Figure 2, Table 1).

Table 1 Mineral Tenures

Claim Name	Tenure #	Map #	Area (ha)
NEWCOPPER WEST	530480	093K	464.44
MAX COPPER	532537	093K	464.44
MAX COPPER 2	532538	093K	464.61

MAX COPPER 3	532540	093K	464.78
MAX COPPER 4	532541	093K	445.9
MAX COPPER 5	532542	093K	371.8
MAX COPPER 6	532543	093K	334.6
MAX COPPER 7	532635	093K	446.14
MAX COPPER 8	532638	093K	222.95
MAX COPPER SOUTH	551895	093K	464.93

Total: 4144.6

3. History

The first documented work on the property is by Arthur A Halleran, Arthur AD Halleran, and Uwe Schmidt who staked the property in 1986 based on gold in streams draining strong magnetic anomalies. The current Max property covers the “Central” portion of a formerly large group of claims explored between 1986 and 1991.

The following historical summary is modified from McClintock, JA, 1991.

“ In 1986, the property was optioned to United Pacific Gold Limited who carried out a preliminary program of geological mapping, prospecting, soil sampling and collection of panned concentrated silt samples. This work, documented in a report by Uwe Schmidt (1988), confirmed the presence of anomalous gold in streams draining the magnetic anomalies and widespread propylitic altered andesite flow and pyroclastic rocks. Several small intrusive breccia ranging in composition from diorite to syenite were also noted. Grid soil sampling located areas of anomalous copper-in-soils.

In 1988, further grid and reconnaissance soil sampling was carried out over portions of the MAX claims. Because of limited financial resources, United Pacific Gold Limited were unable to carry out further work programs and in 1990, sold their interest in the property to City Resources (Canada) Limited. Prompted by the encouraging geochemical, geophysical and geological setting of the MAX claims, Rio Algom Exploration Inc. entered into a joint venture agreement with City Resources (Canada) Limited in May 1990. In 1990, subsequent to acquiring the property, Rio Algom conducted an airborne VLF EM and magnetic survey of the entire claim block, an airphoto interpretation of the surficial geology, grid soil sampling and geological mapping of the Central grid area. This work outlined a coincident copper and gold in soil anomaly exceeding 1.0 km by 0.5 km in dimension, and up to 2.5km by 2.0 km (McClintock, 1990).

Between May 22 and August 12 1991, a comprehensive program of geological mapping, grid soil sampling and reconnaissance induced polarization surveying was carried out on the MAX property to evaluate numerous high-magnetic anomalies for porphyry-type copper-gold mineralization. Between August 14 and September 1, 1991 a program of detailed rock chip sampling, soil profiling and geological mapping was carried out within the Central Grid area of the MAX Option. This work was designed to determine the cause of a broad zone of anomalous copper and gold in soil found by the 1990 grid soil sampling program. Geological mapping found the Central Grid area to contain small multi-phase alkalic plugs, stocks and dykes intruding Takla Group andesite flows and tuffs. Weak propylitic and carbonate alteration, as well as disseminated pyrite and magnetite, are widespread. Detailed rock chip sampling, in conjunction with profile soil sampling, implies the copper and gold-in-soil anomalies are sourced from localized copper and gold bearing shear and vein structures.”

Rio Algom did not pursue the Central zone further. Instead, areas north and south of the Central zone (current Max property) were subject to induced polarization and subsequent drilling with no significant values reported. After 1992, no further assessment work in the area is recorded.

In 1995 the B.C. Government conducted a low level airborne magnetic and radiometric survey as a continuation of the 1991 Mt. Milligan area survey. This Inzansa Lake airborne survey identified very large areas of positive magnetic and radiometric anomalies occurring in the area of the Max property that are similar in character to those found at other known porphyry copper-gold deposits and mines in B.C.. During a B.C. Government Regional geological mapping program around 1995, a copper showing (K-2) was located near the western side of the current Max property.

During June and July 2007, exploration performed by Standard Metals Exploration Ltd. consisted of soil and silt geochemical surveys and limited geology mapping. Rock, soil and silt samples returned positive values of gold and copper, along with geochemically positive values of arsenic, cobalt and rhenium (Blann, 2007).

4. Regional Geology

The MAX property is underlain by the Takla Group, comprised generally of lower Late Triassic sediments overlain by volcanic, pyroclastic and epiclastic rocks that are intruded by coeval plutons up to Early Jurassic in age (Figure 3). Takla Group is divided into four informal formations, the Rainbow Creek, Inzana Lake, Witch Lake and Chuchi Lake Formations. The area near the MAX property contains the Inzana Lake and Witch Lake Formations. Augite phyric basalt predominates in the Witch Lake Formation. These volcanic rocks are potassium rich, transitional into alkalic, and are described as shoshonite in composition, a petrologic name given to other similar and highly productive volcanic rocks in B.C. and around the world. Lower greenschist facies metamorphism predominates. Two regional scale northwest trending fault systems are the Pinchi and Manson to the west and east, respectively. These sub-parallel faults moved in a dextral, strike-slip sense and a complex set of conjugate faults trending northeast connected the two major faults (Struik, 1990). Regionally, two phases of folding are recognized. F1 and F2 folding are probably late Triassic to early Jurassic in age, and likely related to docking of the Quesnel Terrane (Nelson, 1991). Regional scale fault zones occur in proximity with the MAX property on the west, east and south sides, respectively.

Regionally, six large scale intrusive bodies occur, and include granite, syenite, monzonite/monzodiorite, diorite, gabbro/monzogabbro, and are multi-phase, having variable texture and composition on a local scale. The variation in potassium feldspar content and nature of porphyritic textures requires sodium cobaltonitrate staining for identification (Nelson, 1991).

These intrusive rocks are part of the coeval Takla intrusive suite, and along with nearby large scale faults, are important in the development of alkaline, copper-gold porphyry hydrothermal systems in the area and throughout B.C.

Magnetite with intrusive and volcanic rocks reaches 15% locally. Chlorite, epidote, bleaching and pyrite are the most common forms of alteration. Calc-silicate hornfels is developed at the contact of feldspar hornblende porphyry dykes and calcareous units. Disseminations and fracture coatings of pyrrhotite, chalcopyrite and arsenopyrite may occur with calc silicate alteration.”

5. Property Geology

The Inzana Lake and Witch Lake Formations underlie the MAX property. The Inzana Lake Formation (map uTrIL) is comprised of tightly folded grey-green to black siliceous argillite, minor volcanic sandstone, siltstone and minor augite crystal lapilli tuff, sedimentary breccias, heterolithic volcanic agglomerate and rare, small limestone pods. The Inzana Formation is gradationally overlain the Witch Lake Formation (map uTrWL). Refer to Figures 3 and 4.

The Witch Lake Formation is comprised dominantly of augite porphyry flow and pyroclastic rocks, plagioclase porphyry latite, and hornblende plagioclase porphyry. Locally, trachyte breccias occur near the top of the Witch Lake Formation. The Witch Lake Formation is typical of explosive volcanism of intermediate composition and includes flow, hypabyssal intrusion, coarse volcanic breccias, agglomerate, lapilli and crystal tuff and thin bedded subaqueous epiclastic sandstone and siltstone.

At a regional scale, there are four major intrusive phases on the MAX property that are coeval with Takla Group volcanic rocks. These rocks comprise a complex of dominantly monzonite to diorite composition mapped from oldest to youngest as Units 4D, 4A, 3D, 3B, and 3A. Unit 4A and 4D are a coarse grained equigranular diorite/monzodiorite and weakly porphyritic andesite, respectively. Units 3D and 3A are weakly porphyritic latite and equigranular coarse grained monzonite, respectively. Unit 3A is found at Mount Milligan and on the MAX property. Abundant magnetite is notable at both locations. Unit 3B is a key to porphyry copper-gold deposits in the area (Nelson, 1991) and is the host for the MBX and Southern Star deposits at Mount Milligan; this unit is also present on the MAX property. Unit 3D occurs mainly as dikes and occur on the western fringe of the Mount Milligan deposit and on the MAX property. They may be feeders to the Witch Lake and Chuchi Lake volcanic flows. Unit 4A occurs on Mount Milligan and on the MAX property.

Hornblendite and aplite dikes have also been noted on the MAX property. In one locality, hornblendite apparently grades into amygdaloidal extrusive equivalents. Similar hornblendite dikes have been documented on the Tas/Fran property to the west.



Photo 3 Volcanic sediments 5% py Photo 4 Strong epidote alteration Photo 5 Strong epidote veins, 2% py trace cp

The MAX property is underlain to the east by volcanic sediments of the Inzana Lake Formation and Witch Lake, a central complex of intrusive rocks described above, and Witch Lake Formation on the western side. Locally, sediments dip moderately to the northeast as shown in photo 3.



Photo 6 Quartz Carbonate vein, up to 4.78% copper Photo 7 Epidote altered clasts in volcanic breccia

Multiple magmatic phases during regional strike-slip and conjugate shear and fault systems confer locally complex structural configurations within intrusive and overlying volcanic and sedimentary rocks. VLF-EM conductors, and mapped fracture and shear zones suggest dominantly northwest to northeast and locally east-west trending structures occur.

The region is underlain by sedimentary and volcanic rocks of the Upper Triassic to Lower Jurassic Takla Group within the Quesnellia Terrane. The group comprises the informally named Inzana Lake, Rainbow, Witch Lake and Chuchi Lake formations. These have been intruded by alkaline intrusives believed to be coeval with the volcanics. The Witch Lake Formation is composed predominantly of augite ± plagioclase porphyry flows and agglomerates. It is underlain by the younger Inzana Lake Formation (epiclastic volcanic sediments) and the older Rainbow Formation made up of fine grained sediments derived (in

part) from a continental source. Amygdaloidal maroon and green subaerial flows and lahars of the Chuchi Lake Formation overlie the Witch Lake Formation. The claims cover an extensive area of propylitic alteration and sporadic mineralization associated with a polyphase intrusive body. The location coordinates are at the highest elevation on the claims, which is the approximate center of the alteration and the area containing several showings in and around the main intrusive body. The complex intrusive suite includes texturally variable diorite and monzodiorite containing hornblende, plagioclase, augite and more rarely potassium feldspar. Hornblendite and aplite dikes have also been noted on the property. In one locality, hornblendite apparently grades into amygdaloidal extrusive equivalents. Similar hornblendite dikes have been documented on the Tas property. The intrusions cut variable heterolithic augite ± plagioclase porphyry flows and agglomerates, black siliceous argillite and volcanic siltstones and sandstones of the Witch Lake Formation. Propylitic alteration is extensive in the intrusive rocks; epidote and secondary chlorite are abundant. Minor potassic alteration also occurs. The sediments are intensely hornfelsed and display abundant secondary biotite whereas abundant epidote is present in the volcanic rocks. Significant magnetite, up to 20 per cent pyrite, 3 per cent average sulphide content, chalcopyrite, hematite and malachite have been noted in the intrusive rocks. Up to 30 per cent pyrite occurs in the Takla Group rocks. Minor disseminated pyrrhotite is found with chlorite in veinlets. The Rainbow Road West showing contained pyrite, chalcopyrite and fluorite in narrow quartz stringers. A chip sample of diorite containing minor sulphides assayed 0.28 per cent copper and minor gold and arsenic (Property File – United Pacific Gold Limited Prospectus Aug. 1988).

6. 2010 Work

The 2010 exploration program was comprised of a detailed professional evaluation by Dr. Robert Shives, P.Geol., on the Airborne Radiometric and Magnetic surveys over the property that is included in the Appendix 1. To facilitate the interpretation and recommendations by Dr. Robert Shives, historical soil, silt and rock geochemical data for gold and copper were manually entered into computer and locations converted to NAD83 UTM coordinates and are provided in Figures 5 and 6.

7. Discussion

The Max property is located approximately 14 kilometres east of the Tas gold prospect, and 22 kilometres south of Mount Milligan copper gold deposit. The property is underlain by basaltic andesite volcanic flow, breccia heterolithic crystal tuff, and fine grained cherty volcanic sediments that are cut by dikes, sills and a small stock of gabbro, diorite and monzodiorite composition. Subcrop and float boulders of monzodiorite or quartz monzonite also occur. Magnetite and pyrite-pyrrhotite with intrusive and volcanic rocks reaches 15% and 30%, respectively. The volcanic rocks are hornfelsed, biotite and pyroxene and variably chlorite-epidote, quartz sericite carbonate altered. Locally sub rounded clasts of nearly solid pyroxene, epidote and garnet and quartz occur with the volcanic breccia. Strong hornfels and introduction of pyrrhotite, pyrite, trace chalcopyrite, and locally arsenopyrite and sphalerite occur two kilometres beyond the intrusive contact. Large areas of the lower elevations of the property are covered with thick glacial till. Structurally controlled zones of mineralization occur within volcanic and intrusive rocks.

The presence of visible gold flakes and anomalous copper, gold values in stream sediments are significant. The soil and silt sampling in the northeast portion of the Max property has identified elevated and anomalous copper and gold in soils over a distance of approximately 600 metres. In this area, volcanic sediments and volcanic breccia occurs that is moderate to strongly hornfelsed, chlorite epidote and quartz sericite carbonate altered and contains approximately 1-5% pyrite.

The geology, structure, presence of large scale hornfels, calc silicate-pyroxene alteration and pyrite-pyrrhotite, trace chalcopyrite occurs over an area approximately 5 X 5 kilometres in dimension suggest a large scale copper, gold mineralized magmatic-hydrothermal system occurs on the Max property.

Dr. Robert Shives has recommended further evaluation of several priority targets on the property and suggested a methodology that would provide additional help in locating copper-gold mineralization.

8. Conclusions

The Max property is located approximately 57 kilometres north of Ft. St. James in north-central British Columbia, and approximately 14 kilometres east of the Tas gold prospect, and 22 kilometres south of the Mount Milligan copper gold deposit.

On the Max property, outcrops occur predominantly along the higher elevations and steep sided ridges. The property is underlain by Upper Triassic Lower Jurassic volcanic and sedimentary rocks of the Takla Group, and locally, Witch Lake and Inzana Formations. These are the host rocks to the Mt Milligan and Tas copper-gold prospects. In these areas, multiple intrusions of dikes, sills and small plugs occur and are gabbro-diorite, monzodiorite in composition, and possibly more felsic rocks also occur. Intrusive rocks have imparted a strong hornfels in the volcanic and sedimentary rocks, and strong and widespread pervasive and fracture controlled pyroxene, biotite hornfels, chlorite-epidote, sericite, carbonate alteration contains trace to locally 5% or more pyrite, pyrrhotite, magnetite and trace to 1% chalcopyrite locally. Calc-silicate to propylitic style alteration and pyrite occurs over an area approximately 5 km by 5km in dimension. Several narrow shear zones at the K2 prospect contain strong sulphides of pyrite and chalcopyrite, and returned up to 7156 ppm (0.71%) copper and 40840 ppb (40.8 g/t) silver.

Silt and soil sampling of the Max property has identified visible gold in pan concentrates that returned up to 2725.8 (2.7 g/t) gold. A soil grid covering low relief areas west of the Max prospect in the area of the soil grid returned erratic values up to 580.3 ppb gold. Streams draining the northeast side of the Max prospect returned more consistent copper and gold anomalies of up to 98.1 ppm copper, 475.1 ppb gold that together with the large area of alteration and mineralization that occurs, are felt to be of significance for porphyry copper exploration. In this area a reconnaissance soil geochemistry line returned anomalous copper and gold in soils over a distance of approximately 600 metres. This area lies beyond any previously documented exploration and occurs within positive anomalies of an airborne radiometric and magnetic survey.

The occurrence of significant gold and copper values in silt and soil, the widespread presence of alteration and pyrite within volcanic, volcanic-sedimentary, and multi-stage, alkalic intrusive rocks are encouraging and consistent with bulk tonnage alkalic porphyry or a skarn copper-gold geological setting.

A detailed professional analysis of the airborne radiometric and magnetic surveys by Dr. Robert Shives (Appendix 1) has resulted in the identification of several priority target areas worthy of further exploration.

9. Recommendations and Budget

Exploration to date on the Max property has identified a large-scale gold and copper bearing magmatic-hydrothermal system that may be affiliated with an alkalic porphyry or skarn deposit. Further exploration is warranted to delimit the new geochemical anomalies and continue to perform property-wide geology and prospecting with a focus on areas identified by Dr. Robert Shives report.

An induced polarization survey over selected areas of favorable airborne radiometric, magnetic geophysical, and soil and silt geochemical surveys is recommended. Positive results from this work would determine diamond drilling locations.

Phase 1 \$150, 000

- 1) Fill-in existing soil grid in the Fire Lake zone and extend soil coverage to north and west. Reconnaissance or a few lines of soil sampling in the South Ridge area and continued prospecting and geological mapping the south, west and north sides of the property.
- 2) Cut a total of 20 km of Induced polarization geophysical grid over the 2007 soil grid and Fire Lake zone- northeast and southwest of the creek drainage and over the 1990 copper-gold soil anomaly of Rio Algom.

Phase 2: \$400,000

Access road construction and 2,000 metres of diamond drilling.

Respectfully Submitted,

“David Blann”

David E Blann, P.Eng.

10. Statement of Costs

Wages	# Days	\$/Day	Totals
D. Blann, P.Eng	4	700	\$2,800.00

Dr. Robert Shives, P.Geo
Ibex Drafting and GIS

\$5,000.00
\$1,700.00

\$9,500.00

Wages and Disbursements \$9,500.00

Total \$9,500.0

11. References

Blann, DE., 2007, Geological and Geochemical report on the MAX-K@ property, Omineca Mining Division, Assessment report event #4159716.

Donaldson, W., 1991, Max Property, Fort St. James British Columbia, Geology and Geochemistry- Central Grid Area, for Rio Algom Exploration Inc. Operator. Assessment Report 21873.

McClintock, JA., 1991, Max Property, Fort St. James British Columbia, Geology, Geochemistry and Geophysics, for Rio Algom Exploration Inc., Operator. Assessment Report 21736.

McClintock, JA., 1990, Max Property, Fort St. James British Columbia, Geology, Geochemistry and Geophysics, for Rio Algom Exploration Inc., Operator. Assessment Report 20530.

Shives, Robert, 2010, Interpretation Report of 1995 Regional Fixed Wing Airborne Gamma Ray Spectrometric/Magnetic Data over the MAX PROPERTY Omineca Mining Division, British Columbia Canada NTS 93K/16E.

Statement of Qualifications

I, David E. Blann, P.Eng., of Squamish, British Columbia, do hereby certify:

That I am a Professional Engineer registered in the Province of British Columbia.

That I am a graduate in Geological Engineering from the Montana College of Mineral Science and Technology, Butte, Montana, 1987.

That I am a graduate in Mining Engineering Technology from the B.C. Institute of Technology, 1984.

That I have been actively engaged in the mining and mineral exploration industry since 1984

Dated in Squamish, B.C., August 26, 2010

“David Blann”

David E Blann, P.Eng.

Appendix 1

Figures

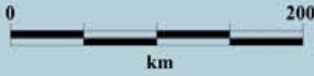
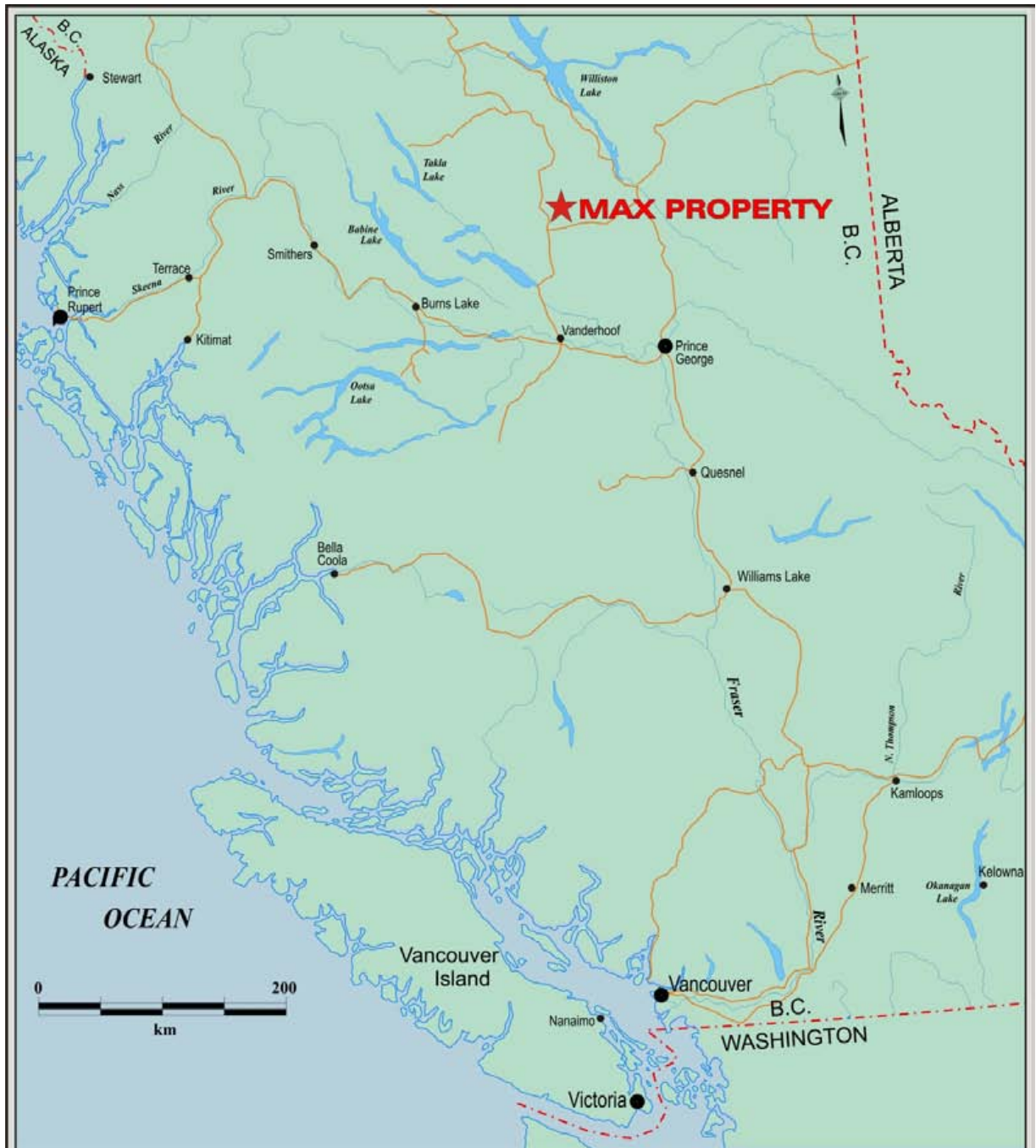

- LEGEND
- ★ A.J.Hewett Max Property
 - Highway
 - River

Anthony James Hewett

MAX PROPERTY LOCATION MAP

British Columbia, Canada

NTS: 93K/16	Mining Div.: Omineca
Date: Feb. 2010	Figure: 1

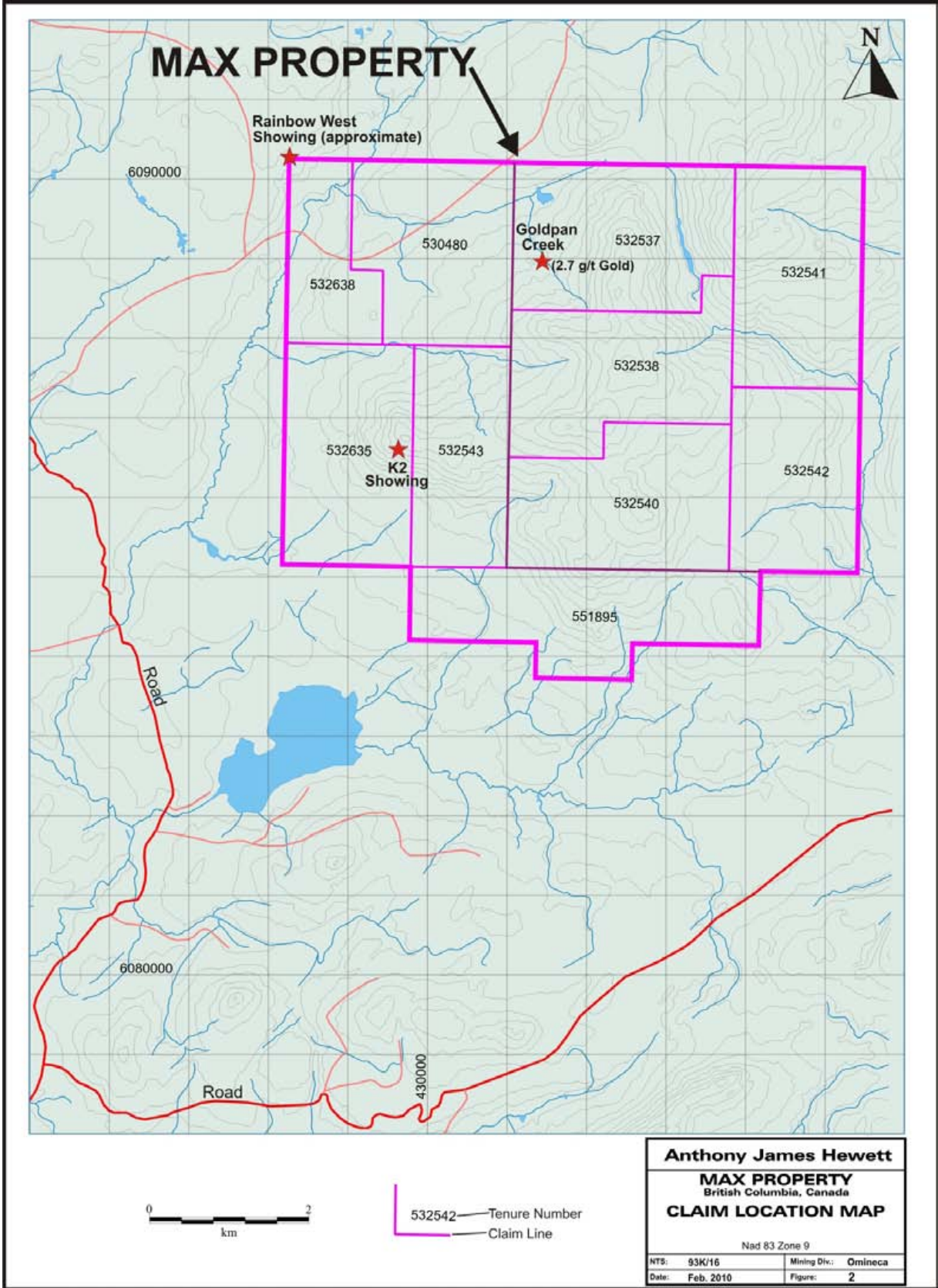

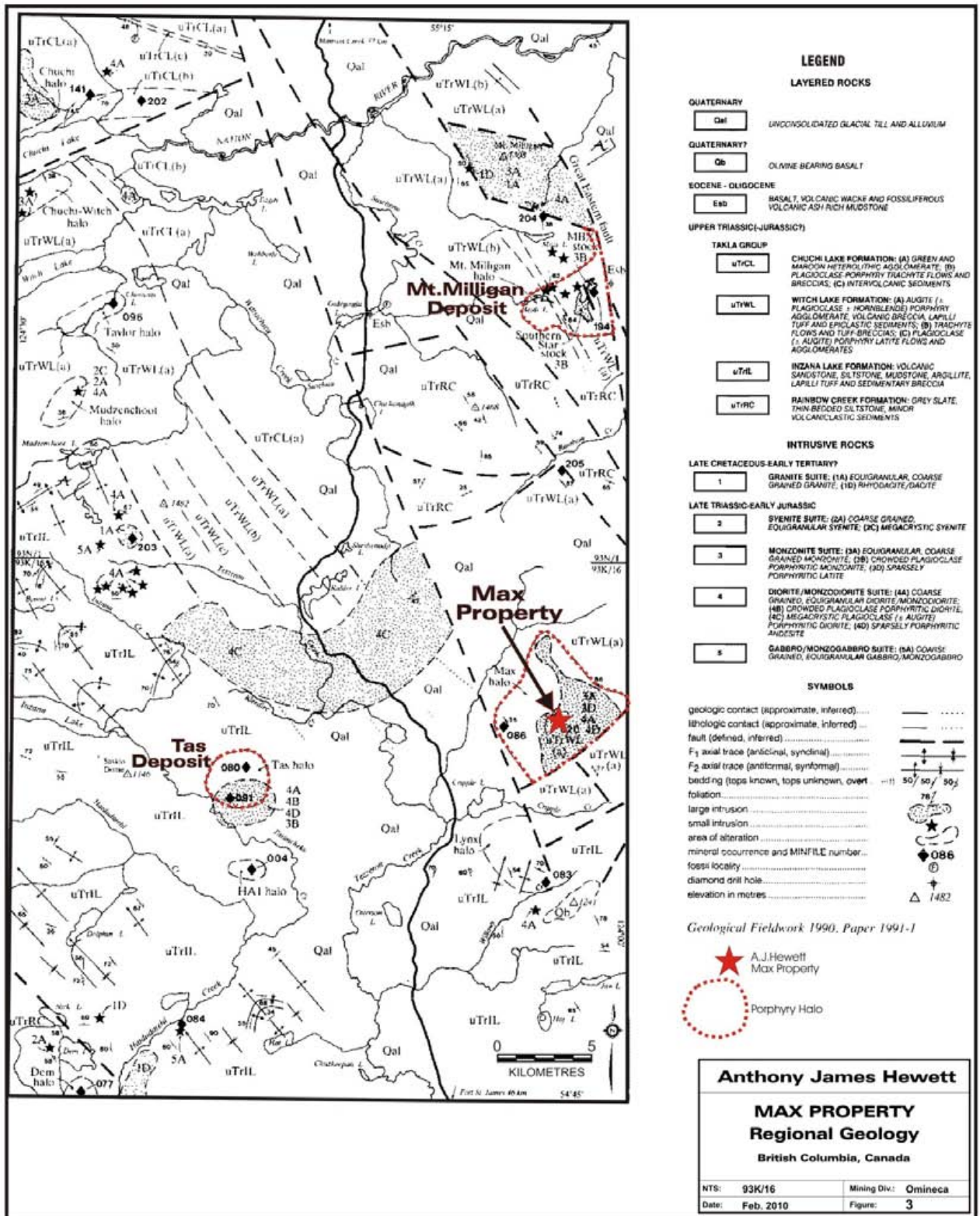

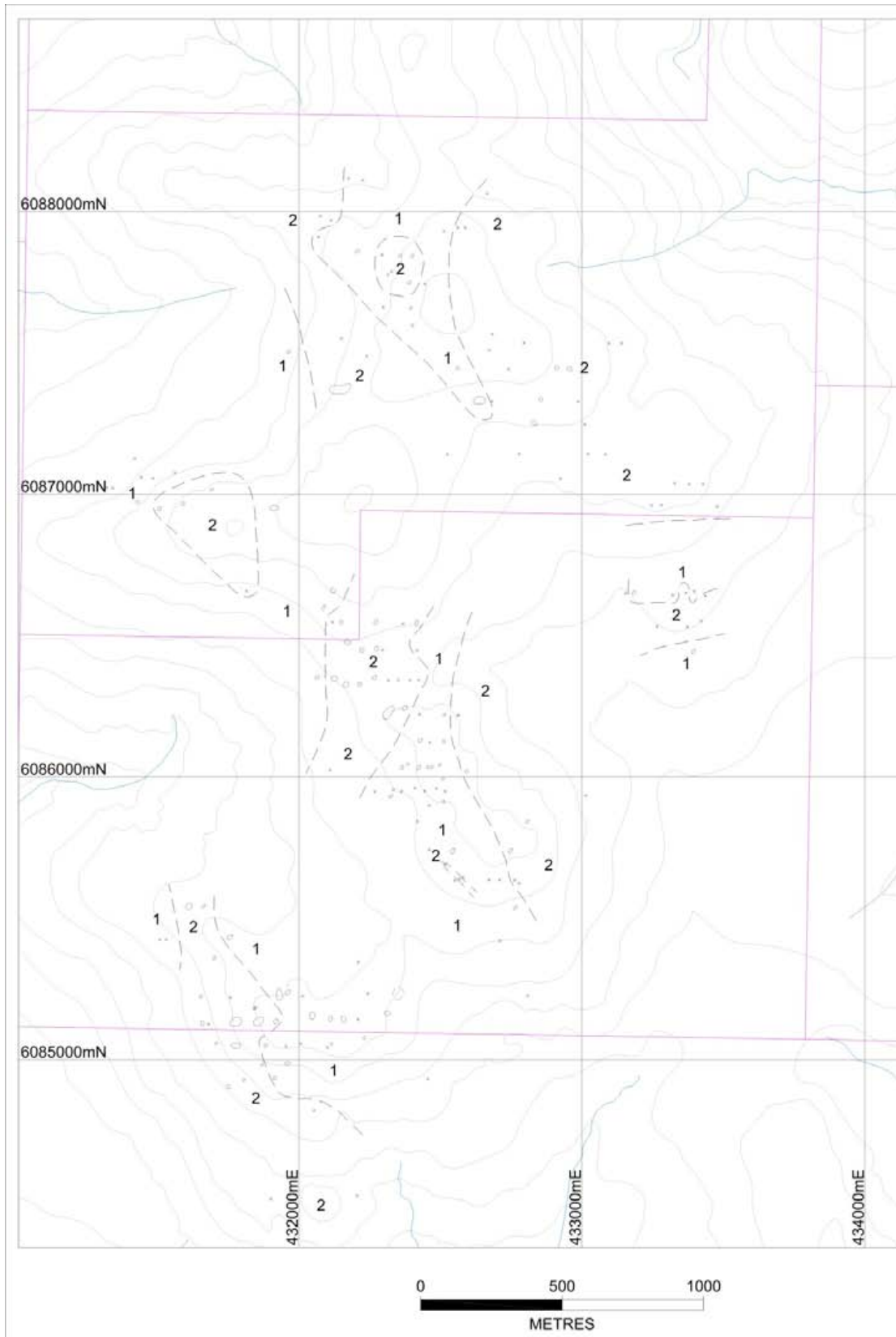

- LEGEND**
- 1 Volcanic Rocks
 - 2 Intrusive Rocks
 - Geological Contact
 - Subcropping
 - Outcrop
 - Geological Showing

ANTHONY JAMES HEWITT
MAX PROPERTY
PROPERTY GEOLOGY

SCALE: 1:500	DRAWN: JCH	FIG.
DATE: 01. 2013	DATE: 04. 2013	4

